SOLID 85E

Operator's Manual

Edition 1.0M



Table of Contents

Chapter	Page
1. Introduction	7
1.1. General Description	7
1.2. Conventions	9
1.3. CE – Conformity	10
1.4. General Safety Instructions	11
2. Installation	13
2.1. Check List	13
2.2. Printer Installation (Environment and Power Standards)	14
2.3. Printer Components	16
3. Handling of Consumables	19
3.1. Loading Paper	19
3.2. Replacing the Toner Cartridge	24
3.3. Replacing the Waste Toner Bottle	28
4. Operation and Menu Structure	31
4.1. Attaching the Printer to a Computer	31
4.2. Printer Power on	31
4.3. Control Panel View	32
4.4. Function of the Control Panel Elements	33
4.5. Configuration via the Control Panel	36
4.6. Menu Structure	38
4.7. Syntax of Diagrams	42

4 Table of Contents

Chapter	Page
5. Panel Functions	43
5.1. Printing the Status Sheet	43
5.2. Printing the Font List	45
5.3. Choosing Print Resolution	46
5.4. Hexdump Mode Activation	48
5.5. Normal Print Mode Activation (incl. FORM FEED)	49
5.6. Clearing the Input Buffer (Cancel Job)	50
5.7. Printing the Menu Page	51
5.8. Generating Test Prints (Sliding Pattern)	52
5.9. Page Length Adjustment	54
5.10. Selecting the Number of Printpages per Page Format (Two-Up Mode)	56
5.11. Paper Width Adjusting (Format Width)	58
5.12. Print Direction Selection	59
5.13. Data Interface Configuration	60
5.14. Emulation Selection	61
5.15. Display Language Selection	63
5.16. Transparent Code Adjustment	64
5.17. Selection of Memory Distribution (Input Buffer)	65
5.18. Setting to Factory Default	66
5.19. Font Selection	67
5.20. Text Orientation Selection	70
5.21. Symbol Code Selection	71
5.22. Configuration of Text Margins	72
5.23. Image Shifting to the X-Direction	73
5.24. Image Shifting to the Y-Direction	75
5.25. Lines per Inch Setting (Line Spacing)	77
5.26. Number of Characters per Inch Setting (Character Spacing)	78
5.27. Print Density Setting	79
5.28. Configuration of Network Parameters (IP Address, e.g.)	80
6. Printer Cleaning	83
6.1. Cleaning the Elements behind the Front Cover	84
6.2. Cleaning the Transport Unit	88
6.3. Cleaning the Paper Feed Unit	91
6.4. Cleaning the Paper Near End Sensor	92
6.5. Cleaning the Power Stacker	93

Chapter	Page
7. Operator Maintenance	95
7.1. Charger Cleaning	95
7.1.1. Main Charger Cleaning	96
7.1.2. Pre-Charger Cleaning	100
7.1.3. Transfer-/Separator Charger Cleaning	102
7.2. Developer Unit Cleaning	105
7.3. Developer Unit Refurbish, Developer Powder Exchange	110
7.4. Main Charger Replacing	117
7.5. Pre-Charger Replacing	118
7.6. Transfer-/Separator Charger Replacing	120
7.7. Photoreceptor Drum Exchange	122
8. Troubleshooting	131
8.1. Reduced Print Quality	132
8.2. Error Messages	133
8.2.1. Further Error Messages and Error Codes	136
8.3. Paper Jam	139
8.3.1. Paper Jam inside the Tractor	139
8.3.2. Paper Jam inside the Print System	140
8.3.3. Paper Jam within the Power Stacker	145
8.4. Print Repetition after an Error	146
9. Measures for Transport and Shipping (Repacking)	147
10. Specifications	149
11. Index	153

1. Introduction

1.1. General Description

The print system SOLID 85E works on an electrophotographical base employing an LED array as exposure unit. The maximum resolution of 600 dots per inch is corresponding to about 24 pixels per mm. The print speed is up to 85 pages per minute in the Two-Up mode .

Exclusively continuous media with sprocket holes can be used for the tractor guiding. The maximum material width is 18 inches, the printable width is 17 inches. This enables you to print two A4 portrait pages side by side (Two-Up). A stacker is included in the standard device.

The non-contact Xenon flash fusing system in combination with the straight paper flow enables you to use the most different paper types and label materials with a weight from 60 to 204 g/m². Even demanding media like plastic, PVC etc. can be used.

Consequently there is a multitude of scopes for this print system. It is suitable for high-speed printing with excellent print quality using different types of materials.

The high functionality of the MICROPLEX controller specially qualifies the SOLID 85E also for form printing.

The printer is capable of using most of the page description languages used in the industrial field and also the business standards known in connection with laser printers can be used.

The capabilities featured include the MICROPLEX page description language IDOL. Using this language, complex tasks such as the creation of forms can be carried out by simple software commands (see separate IDOL manual).

Data can be sent from almost any software platform, because printer drivers are already available for this.

The MICROPLEX printer controller has its integrated website, this allows a printer configuration via Ethernet. See [Networking Features of MICROPLEX Printers](#) for more information.

Consequently there is a multitude of scopes for this print system. It is suitable for high-speed printing with excellent print quality using different types of materials.

Printing Basics

The MICROPLEX printer controller enables the connection of this print system to EDP systems whereby several interfaces, emulations and fonts are available.

The digital information (e.g. a text file) is transferred from the computer into the printer memory. The printer's electronic component (the controller) combined with the page description language, defines the letters, numbers, graphics, etc. into bit patterns and posts them into the controller's frame store.

In this way, a "pattern" of the future print page (generated by dots) is created.

The electronically controlled LED (Light Emitting Diode Array) plots the dot pattern in rows onto the light-sensitive surface of a rotating pre-charged drum. Toner is caused to adhere to the electrostatic latent image formed on the drum surface. This image consisting of toner particles is electrically transferred onto the paper, that is guided past the drum.

When transported further, the toner particles, which are affected by the Xenon flash fusing, are combined resistantly with the paper. The drum is discharged and cleaned.

1.2. Conventions

The following conventions should help you to find information and to understand instructions more easily:



This symbol refers to a possible source of danger. Disregarding the information identified by this symbol could result in injuries, a reduction of printer functionality, or damage to the printer or other objects.



This symbol indicates important hints and suggestions on using the printer. Disregarding the hints might cause problems with the printer or within the environments.



This symbol shows a control panel key. Such symbols will be used in this manual whenever keys have to be pressed in order to activate certain functions.

[blue colored text](#)

Link to another chapter or a different document. By clicking the blue colored text you'll enter the concerning chapter or document.

[Menu Level 1]

This symbol represents messages shown in the display (panel).

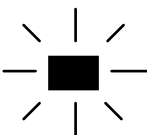

This symbol is used to show a shining LED (light emitting diode). The SOLID 85E printer panel is provided with several LEDs. The real shape of the LEDs differs from the shape of this symbol (compare figure in section 4.3).



This symbol will be used in this manual to show a non-shining LED.

1.3. CE – Conformity



EC DECLARATION OF CONFORMITY

Manufacturer: **MICROPLEX Printware AG**
Panzerstrasse 5
D-26316 Varel
Germany

Product: Printer (LED)

Type: SOLID 85E

Conforms with the following EC directives: EN 60950-1 (Low voltage directive)
EN 55022/Class A (Information technology equipment –
Radio disturbance characteristics – Limits
and methods of measurement)

EN 55024, EN 61000-6-2 (Immunity for industrial environments)
EN 61000-3-2 (Limitation of voltage changes, voltage
fluctuations and flicker in public low-
voltage supply systems)
EN 61000-3-3

Varel, 12. 11. 2012



Managing Director
Jürgen Schmitt

On the basis of this declaration, this product will bear the following mark:



1.4. General Safety Instructions



This device produces, employs and possibly radiates high frequency energy. Because of this, incorrect installation can disturb radio communications.

This MICROPLEX product and its consumables are designed and tested according to strict safety standards.

Heeding the following instructions ensures secure operation:



- Make sure that your electricity source is grounded adequately.

- Install the device on solid and level ground.

- Only trained staff is authorized to transport the equipment.

- Only use consumables which are specially developed for this device.



- Unsuitable consumables may reduce printer output quality or cause damages.

- No liquids should get on or into the device.

- Do not remove any cover or safety device fastened by screws.



- Do not bridge a safety device.
- Do not push anything into the ventilation apertures.
- Never perform installations, cleanings or maintenance work that is not described in this manual. Such work should only be done by MICROPLEX authorized service personnel.
- To avoid damage, the devices must be switched off (i.e. cut off from the power supply) before the user begins connecting the interface line.



In case of emergency, in order to disconnect the printer from the main power, please note the following:

- For connected printers with plugs, an easily accessible power-outlet should be installed near the printer.
- For permanently connected printers, an easily accessible emergency power-off switch should be installed close to the printer.
- Please do not conceal any disconnect devices with the printer or other objects.



- Please follow all the information and hints directly attached to the device and/or described in this manual.
- To ensure optimum printer performance, only use MICROPLEX consumables.

2. Installation

2.1. Check List

First, place the printer and the accessories onto a level surface until the definitive location is chosen.

Please make sure that all items are included and that there are no defects. Immediately inform your supplier of any damage.

Open the cardboard box carefully and check the contents:

1. MICROPLEX Printer SOLID 85E
2. Developer Unit
3. Developer (powder)
4. Toner
5. Photoreceptor Drum
6. Cleaning Unit
7. Stacker
8. CD containing:
 - Operator's Manual SOLID 85E
 - Print drivers
 - IDOL Programming Manual



The printer's first installation has to be done by a trained service engineer.



Please retain the original packing materials in case the printer has to be transported in the future.
Use the original packing materials and adhesive fasteners to avoid damage to the internal components.
(See chapter 9 Measures for Transport and Shipping (Repacking)).

2.2. Printer Installation (Environment and Power Standards)

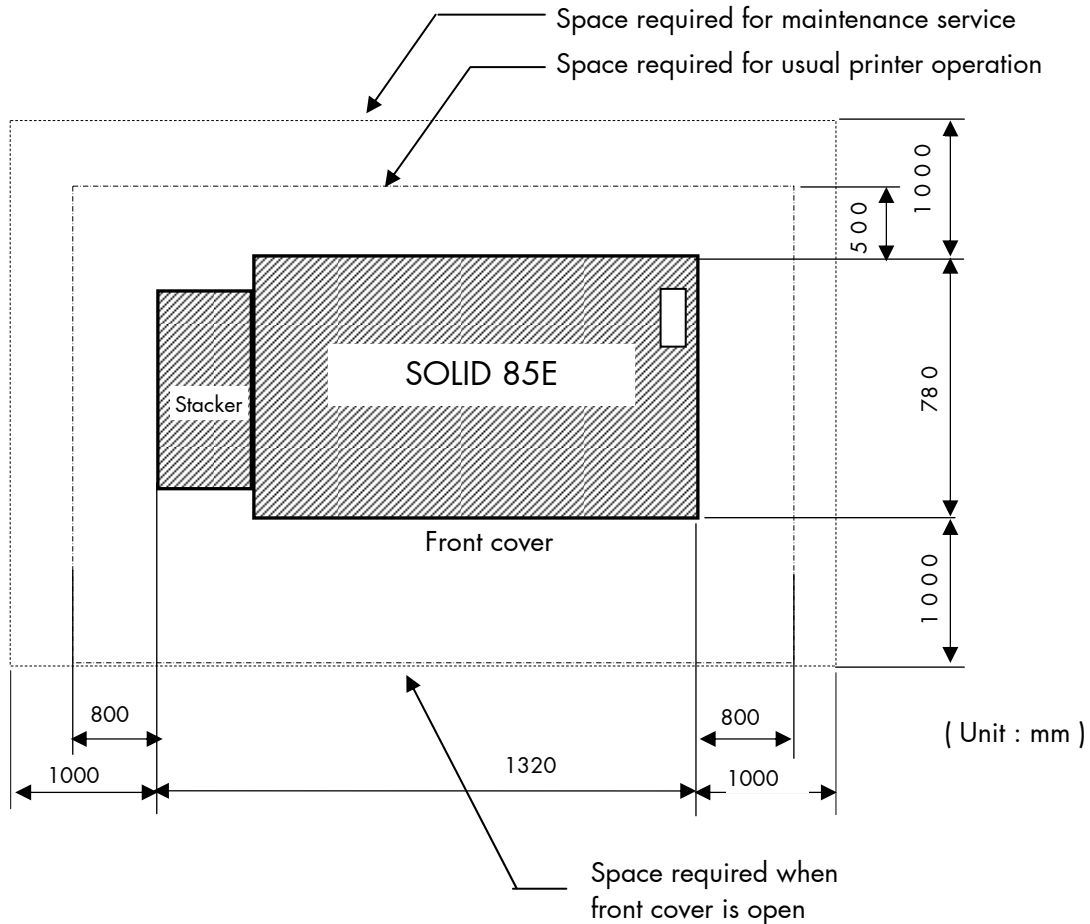

Fig. 2.2.a SOLID 85E: Required space (plan view)



- The chosen location should be well ventilated.
- Damaging environmental factors such as metal vapors, oil mist, corroding lixivium or the like must not come in contact with the printer.
- Position the printer on solid and level ground.
- Do not expose the printer to shocks or vibrations.
- The printer should not be located near volatile or combustible materials (e.g. a curtain).



The printer's first installation has to be done by a trained service engineer.

- Avoid locating the printer close to an air current (e.g. ventilators).
- The printer should not be exposed to direct sunlight.
- Do not touch the drum surface because the material is easy to damage.
- Do not expose the printer to abrupt temperature changes.
- In order to run the printer reliably, please maintain the following environmental conditions:

Temperature: +15°C to +30°C (59°F to 86°F) operating
-10°C to +35°C (14°F to 95°F) non-operating
Relative humidity: 30% to 80% operating
10% to 80% non-operating



Power standards:

- Please connect the power plug to 230 V AC, 50 Hz (Europe, United Kingdom e.g.).
- The max. effective power input is appr. 5.5 kVA.
- The voltage support must not be impaired by interference.
- The printer is provided with a flexible 3x2.5 mm² connection cable including a CEE plug 3x32. The corresponding CEE socket has to be provided with a $\geq 25A$ fuse.
- If using an equivalent fixed connection ensure the grounding is effected.
- Use the printer only within the allowable fluctuation range $\pm 10\%$ of the power voltage.

Conditional connection for the SOLID 85E:

The maximum permissible system impedance Z_{\max} is appr. 0.02 Ohm. The user of this device has to determine in consultation with the supply authority, if necessary, that the equipment is connected only to a supply of that impedance or less!



To avoid damage, the devices must be switched off (i.e. cut off from the power supply) before the user begins connecting the interface line.

2.3. Printer Components

External Views:





Interfaces (Detail View):

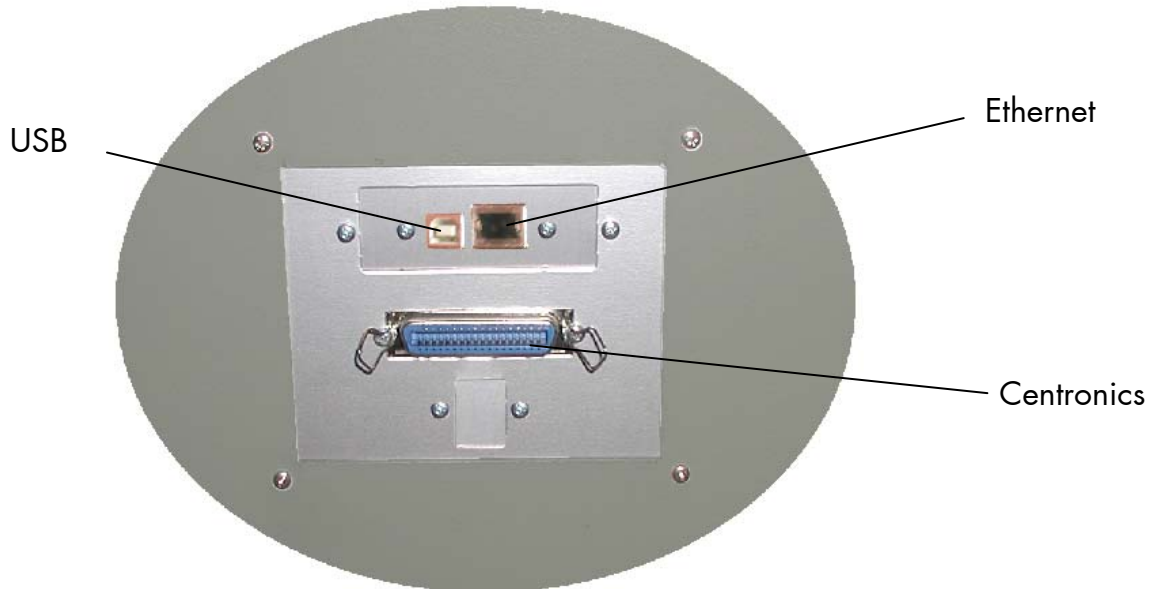

Printer interior view:

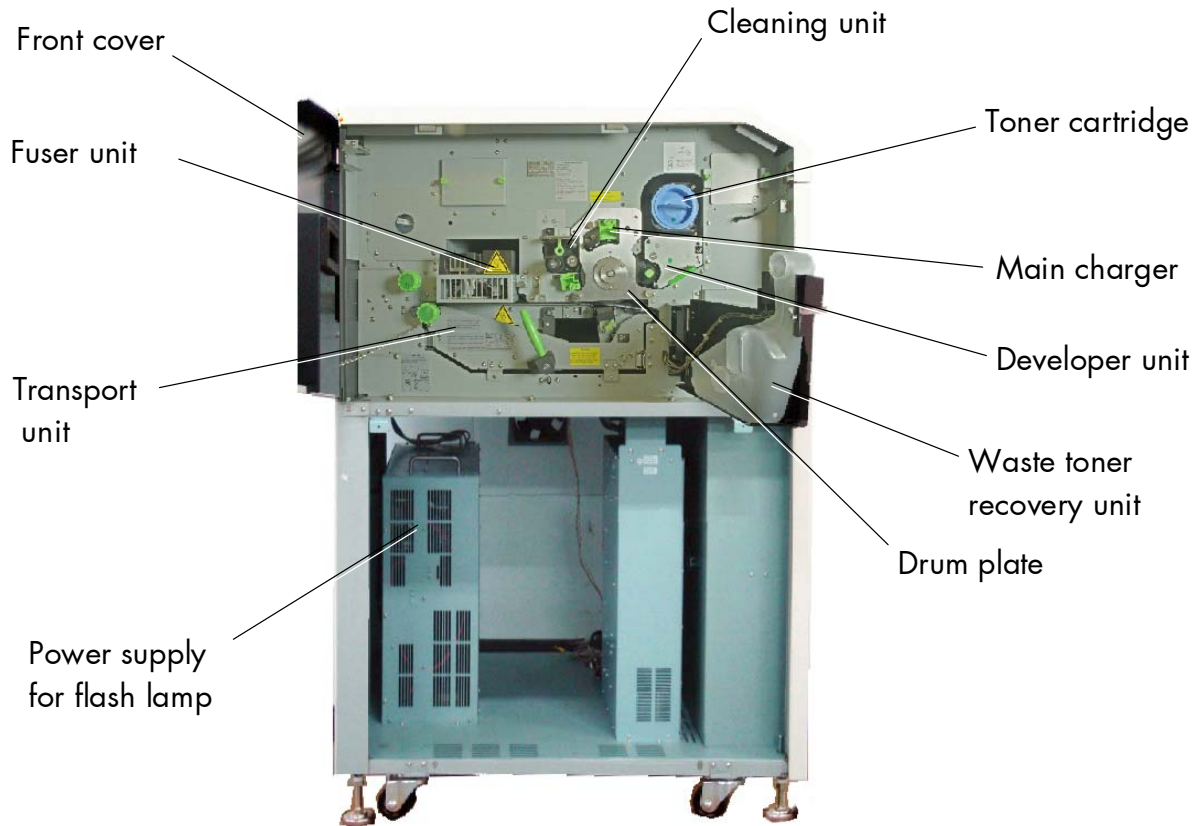

3. Handling of Consumables

3.1. Loading Paper



The printer processes continuous paper in lengths from 7 to 24 inches and width from 6 to 18 inches (including the perforated margins, 17 inches printable).

You can check the printer configuration (inclusive the settings regarding paper length etc.) by printing a status sheet (see section 5.1).



If a large quantity of paper with a paper width smaller than 18 inch has been processed, the printer has to be cleaned first before you start to process paper with a larger paper width. See chapter 6 Printer Cleaning (especially section 6.2 Cleaning the Transport Unit) and chapter 7 Operator Maintenance (especially section 7.1 Charger Cleaning).

1. Turn the printer OFF LINE.
2. Make sure the left tractor is in the left position.

Left Tractor

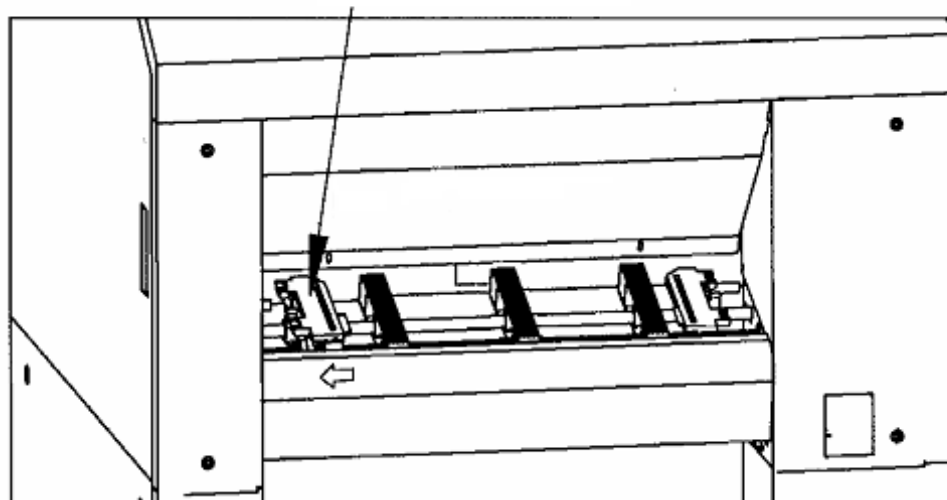

3. Place the box containing the fanfold paper below the tractor unit as shown below.

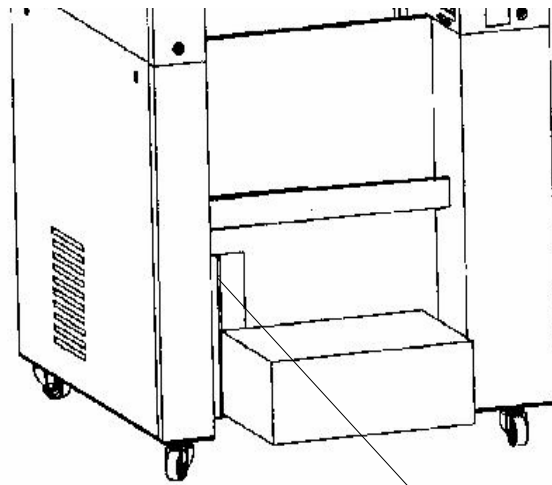

Mark for the left
paper margin

4. Pass the fanfold paper through the sensor guide (Paper Near End Sensor PNES).

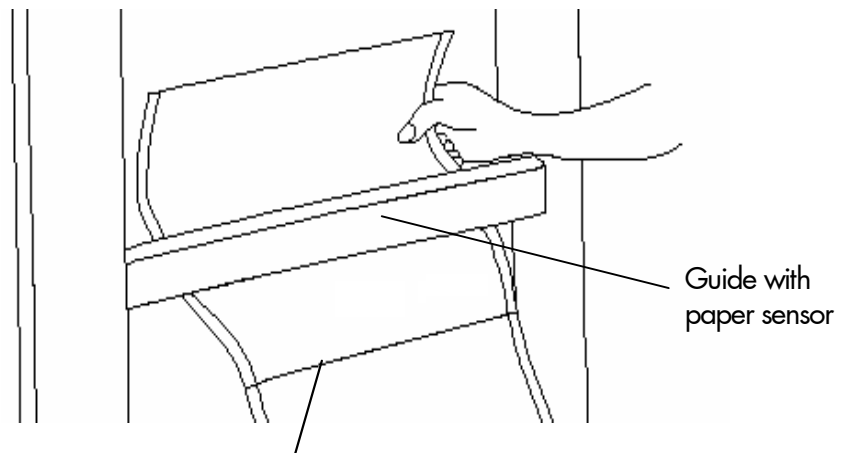

Guide with
paper sensor

Folded edge of the paper



To avoid paper jams the first folded edge of the fanfold paper (Perforation) has to point away from the printer. (If need be, please tear off the first page of your fanfold paper to allow the alignment shown in the following figure.)

In addition do not stretch the paper excessively and do not allow any slack to avoid incorrect filing.

By this you can secure that the paper will be positioned right in the stacker.

Preview: Fanfold paper loaded in the right way



5. Please unlock the right tractor. For that you have to turn the lever (tractor lock lever) of the right tractor into the vertical position.

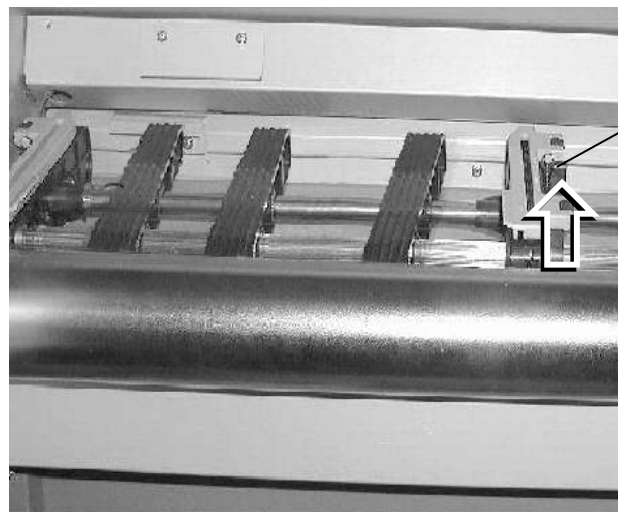

6. Open the two tractor cover plates by turning them into the upright position.

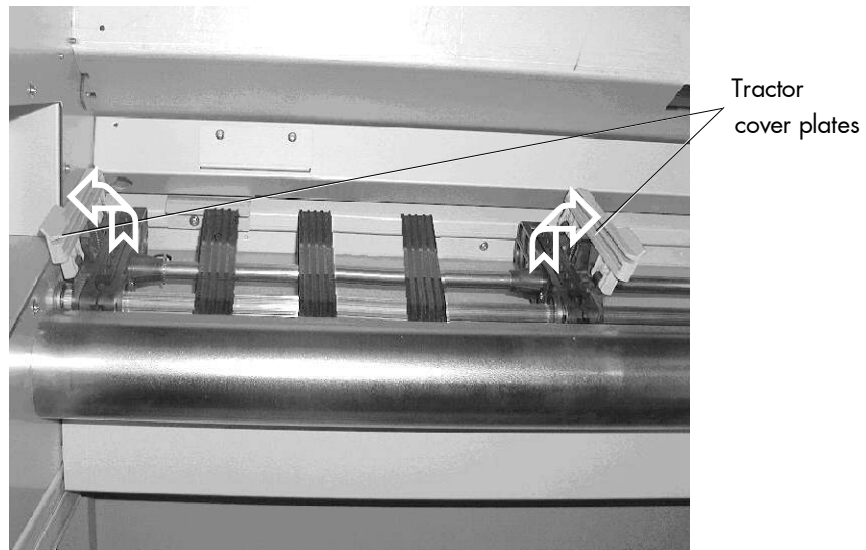

7. Place the paper on the tractor pins on the left side. The paper perforation should be aligned over 4 or 5 tractor pins. Close the left tractor cover plate.
8. Spread out the tractor so that the sprocket holes on the right side of the continuous paper can be placed easily onto the tractor pins.

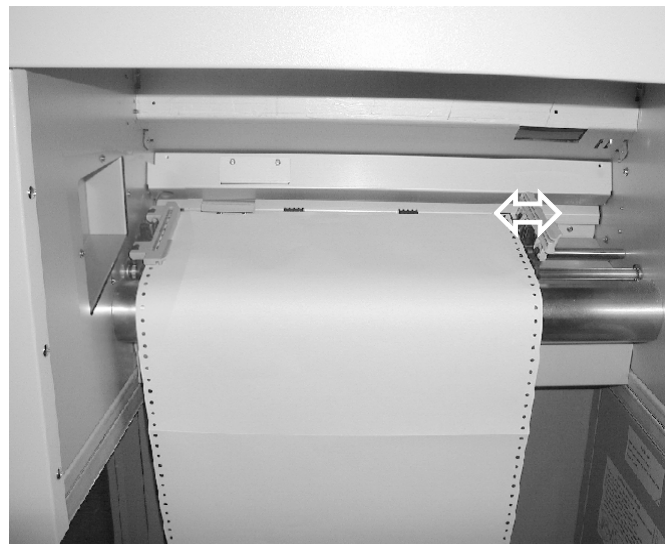

The paper sensor in the middle of the tractor has to be covered by the paper. On the other hand the paper must not reach into the printer too far.

9. Close the right tractor cover plate and tighten the paper **gently** with the right tractor.



To avoid paper jams the paper must not be inserted too loose or too tight.

10. Lock the right tractor by using the lock lever.

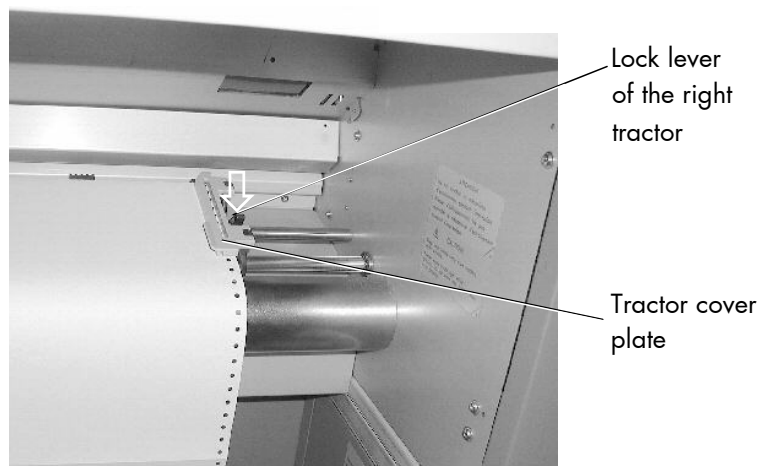

11. Turn the printer ON LINE. The newly aligned paper will be driven to the start position automatically.

12. If necessary adjust the printer to the new page length (see section 5.9).

3.2. Replacing the Toner Cartridge

Please replace the toner cartridge, when the message [TONER EMPTY!] is displayed.

With one toner filling approximately 20,000 pages A4 with a print density of 5 % can be printed (compare chapter 10 Specifications).



Please wear vinyl gloves to avoid dirty hands when replacing the cartridge.

1. Open the front cover of the printer.

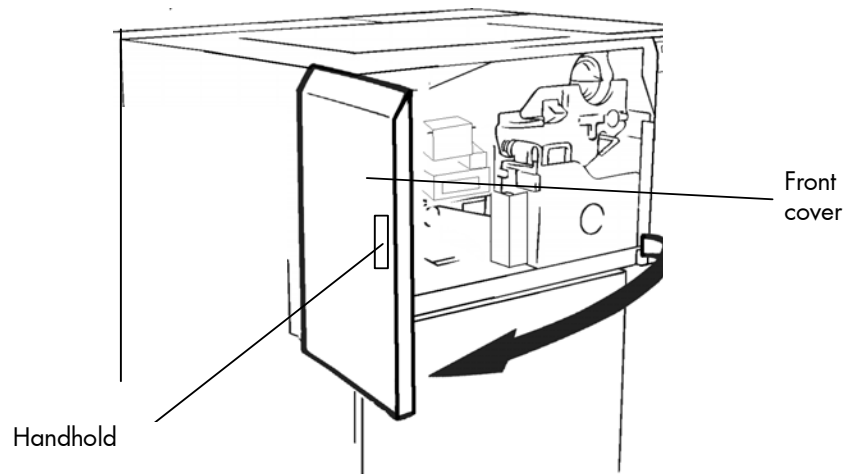

2. Rotate the used toner cartridge 180° counterclockwise until it stops. Pull out the cartridge.

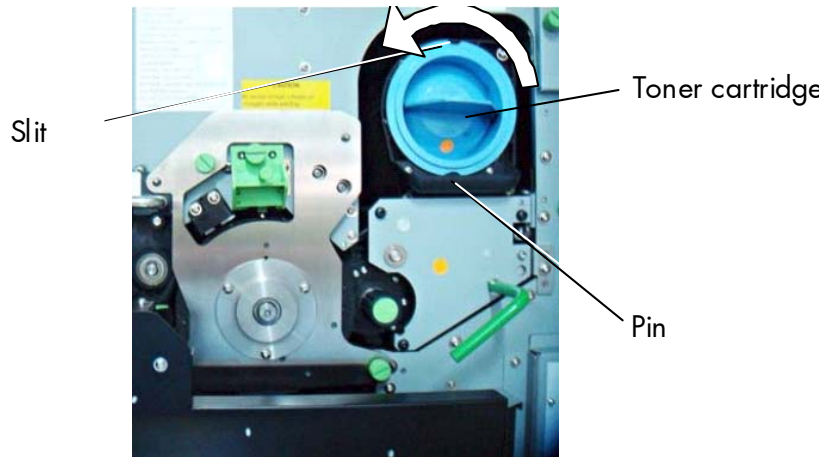

3. Take the new toner cartridge out of the packing. Use the vinyl bag to pack the old cartridge.



On the occasion of every toner cartridge replacing the necessity of cleaning the developer unit has to be checked. Cleaning the developer unit has to be done in due time to avoid reduced print quality (see section 7.2).

4. Shake the new cartridge gently by performing horizontal movements to distribute the toner.

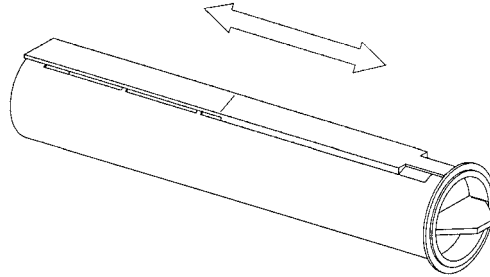

5. Put the end of the new cartridge into the SOLID 85E toner hopper with the adhesive tape facing up, and slowly strip off the tape from the front to the back. Slide the cartridge gently into the device in one operation.

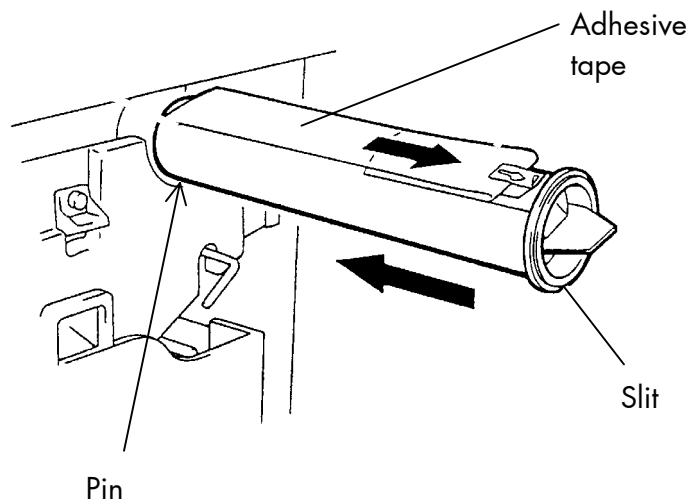

6. Insert the cartridge deeply into the toner hopper until it stops. For that you have to align the toner cartridge slit with the developing unit pin. Then slowly turn the cartridge 180° clockwise.

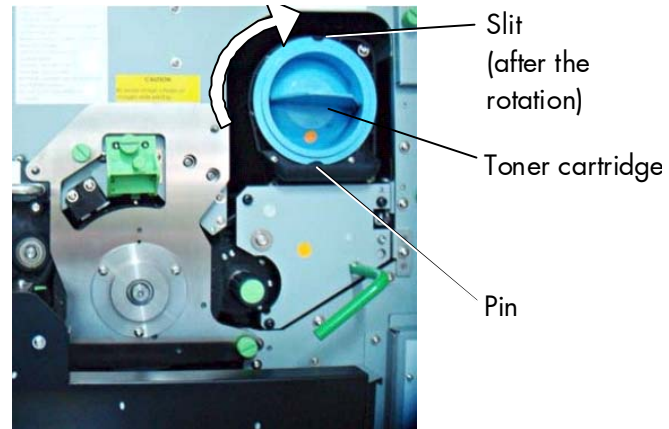

7. Close the printer's front cover.

The announcement [TONER EMPTY!] will be extinguished.



The toner is easily combustible and should never come in contact with fire. Disposal will be carried out by your service engineer. Until disposal please store the cartridge in a vinyl bag in a closed cardboard box.

3.3. Replacing the Waste Toner Bottle



Replace the waste toner bottle when the announcement [TONER WASTE!] occurs. On average, the bottle will be filled after 100,000 A4 pages have been printed.

1. Open the front cover of the printer.

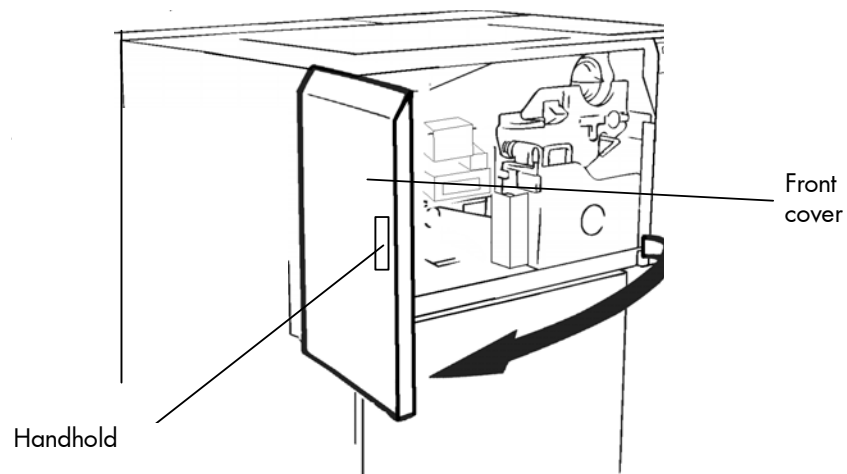

2. Press down the open lever of the waste toner recovery unit and open the unit.

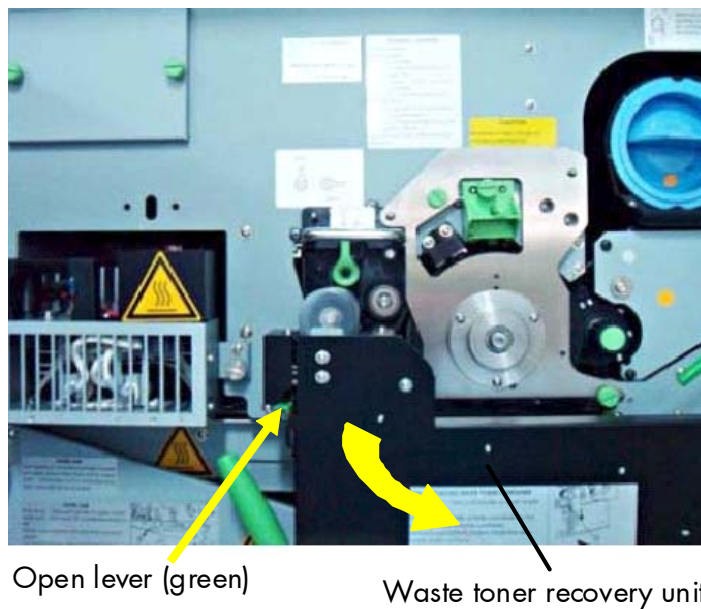

3. Take off the cap outside the waste toner recovery unit and close the bottle.

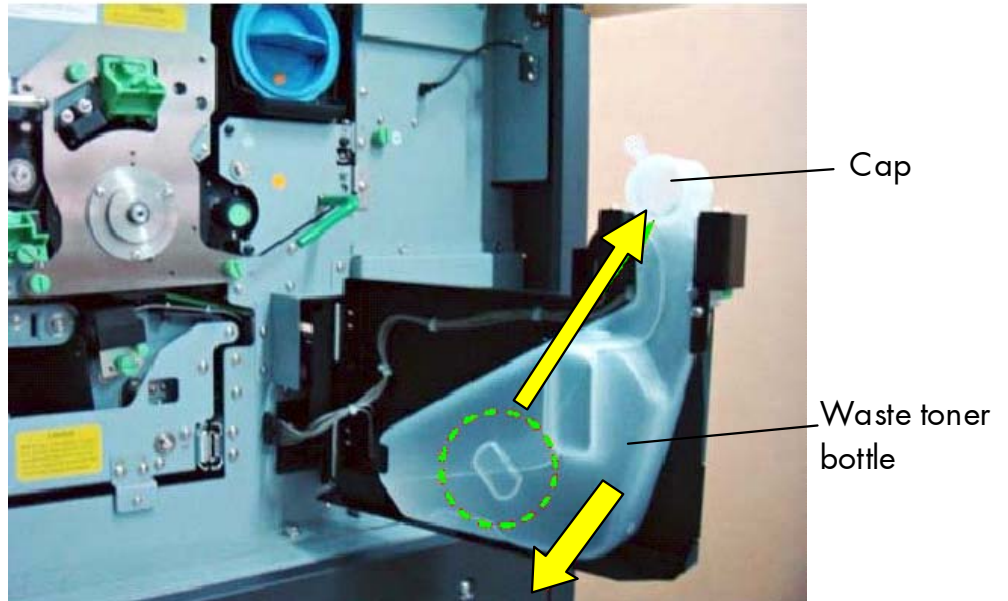

4. Take out the waste toner bottle completely.

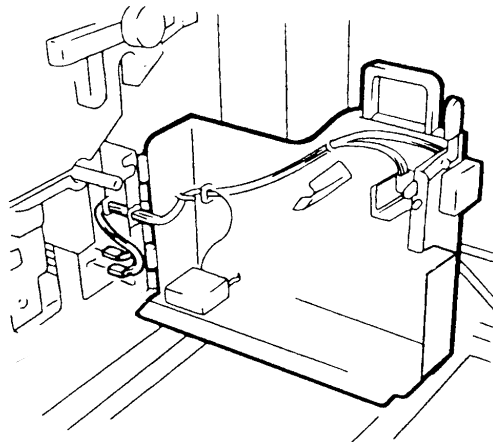

5. Insert the new bottle into the waste toner recovery unit.



Close the waste toner recovery unit. Make sure the bars click into place.

6. Close the printer's front cover.
The announcement [TONER WASTE!] will be extinguished.



The waste toner is easily combustible and should never come in contact with fire. Disposal will be carried out by your service engineer. Until disposal please store the waste toner bottle in a vinyl bag in a closed cardboard box.

4. Operation and Menu Structure

4.1. Attaching the Printer to a Computer

1. Make sure the printer, computer, and any other attached devices are turned off and unplugged.
2. Use a proper interface line to connect the printer to the computer or to attach the printer to the network.
The printer SOLID 85E is provided with several interfaces; see chapter 10 Specifications for more information.

4.2. Printer Power on

The power switch is located at the right side of the printer (see section 2.3 Printer Components). As soon as the printer's warm up phase is finished the print system SOLID 85E goes into the ON LINE mode. The Online LED and the Ready LED shine and the name of the printer is displayed.

4.3. Control Panel View

The control panel offers you:

- information about the actual state of the device (panel and LEDs).
- direct command input using the keyboard.

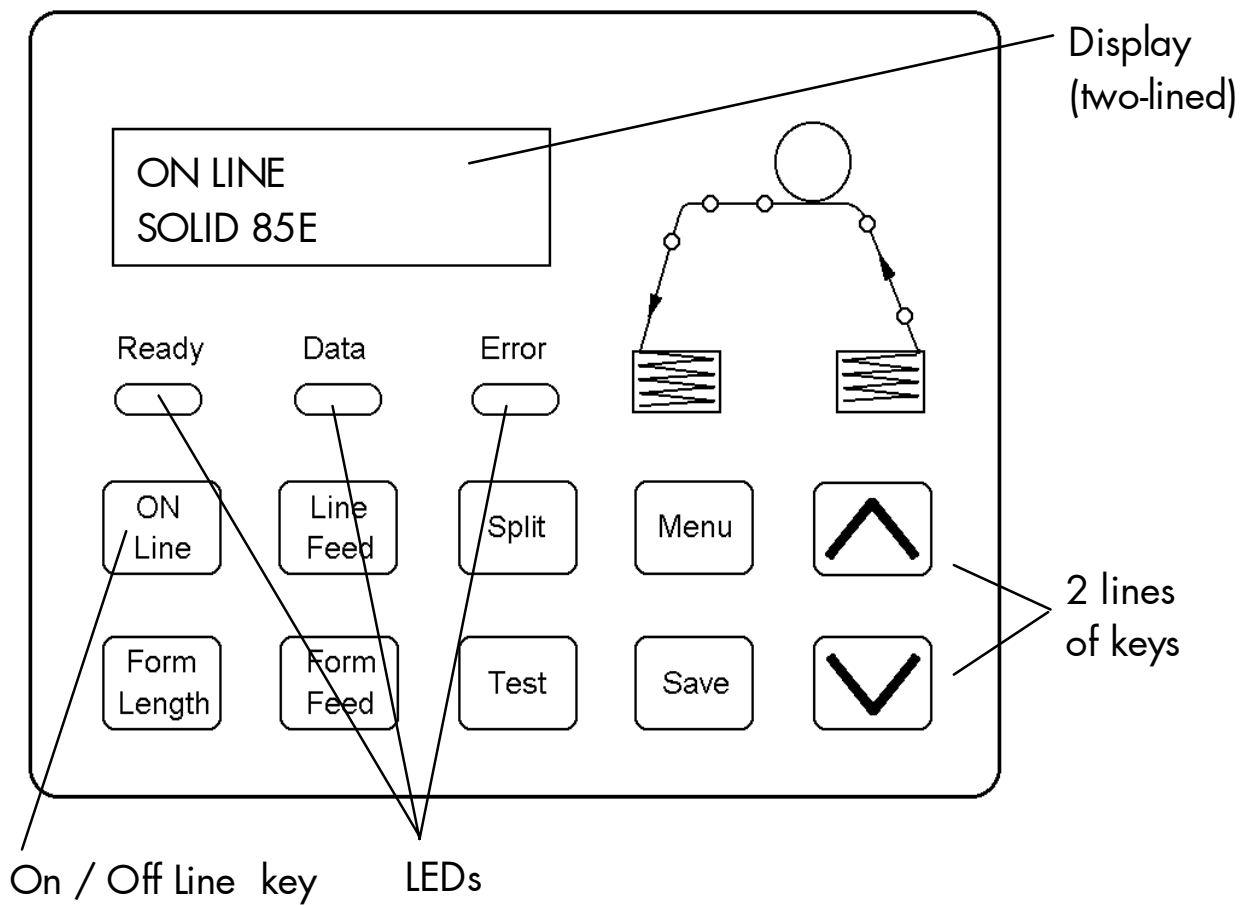

4.4. Function of the Control Panel Elements

Display

The display (panel; 2 x 16 character LCD) serves to show the printer's messages.

LEDs

Meaning of the LED Announcements:
The printer control panel contains the following LEDs (Light Emitting Diodes):

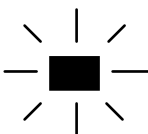
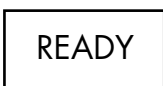

The printer is ready to operate, initializing has been completed, the photoreceptor drum is warmed up etc.



The phase of initializing is not yet completed.

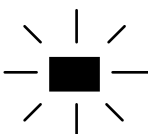

The printer receives printable data.



There are no printable data in the input buffer.

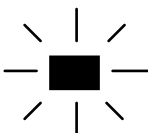

An error occurred in the printer. The printer is OFF LINE.



No error occurring.

Control Panel Keys



This symbol shows the ON LINE key. This key is used to turn the printer ON LINE or OFF LINE.

The other control panel keys are only active in the OFF LINE mode.



The current form length is announced. The form lengths from 7 to 20 inches can be selected in 1/6 inch steps.



The cutting device can only cut paper along the perforation, so the set form length has to correspond with the current paper size. Wrong settings lead to paper jams.



Paper will be transported 1/6 inch forward.



After loading new paper the paper will be driven to the start position. Apart from that activating the FORM FEED key in the OFF LINE mode will move the paper one form length ahead.



The last print job will be cut at its end and the paper will be moved to the park position.



A status sheet will be printed (see section 5.1 Printing the Status Sheet and section 5.8 Generating Test Prints, too).



These keys are used for working within the different levels of the menu structure described in the following chapters.

4.5. Configuration via the Control Panel

You can use the control panel to change the printer configuration and customize your printer to meet your specific needs.

In addition printer configuration via Ethernet is possible. The MICROPLEX printer controller offers an integrated website, for more information see [Networking Features of MICROPLEX Printers](#).

Chapter 5 (Panel Functions) describes how to reach the particular printer functions via the control panel.

T e m p o r a r y changes in printer configuration are effective only as long as the printer stays turned on. To select such changes temporarily, the user must terminate the change of function by pressing the **SAVE** key one single time.

P e r m a n e n t changes in printer configuration are active each time the printer is turned on again. To select such changes permanently, the user must terminate the change of function by pressing the **SAVE** key **two times**.

An output of the current printer values can be generated using the "Status Sheet Printing" panel function (see section 5.1).

Please note:

- User default settings remain in effect until you save new settings or restore the factory defaults.
- Settings you choose from your software application or printer driver can also change or override the user default settings you select from the touch panel.

Switching the Printer OFF LINE

After the printer was turned on (and as soon as the warm up phase is finished) the printer goes into the ON LINE – Mode.

[SOLID 85E] The display of the control panel shows the name of the printer.



This symbol shows the ON/OFF LINE key. If the printer is turned OFF LINE with this key you get automatically into the first menu level.

[Menu Level 1] Now this message is shown by the display of the control panel.

In the interest of simplicity, in the following chapters only the most important display messages are shown in the Panel display column.

4.6. Menu Structure

Access to the menu structure is possible as soon as the printer is turned OFF LINE.
 The SOLID 85E menu structure is arranged in different levels:

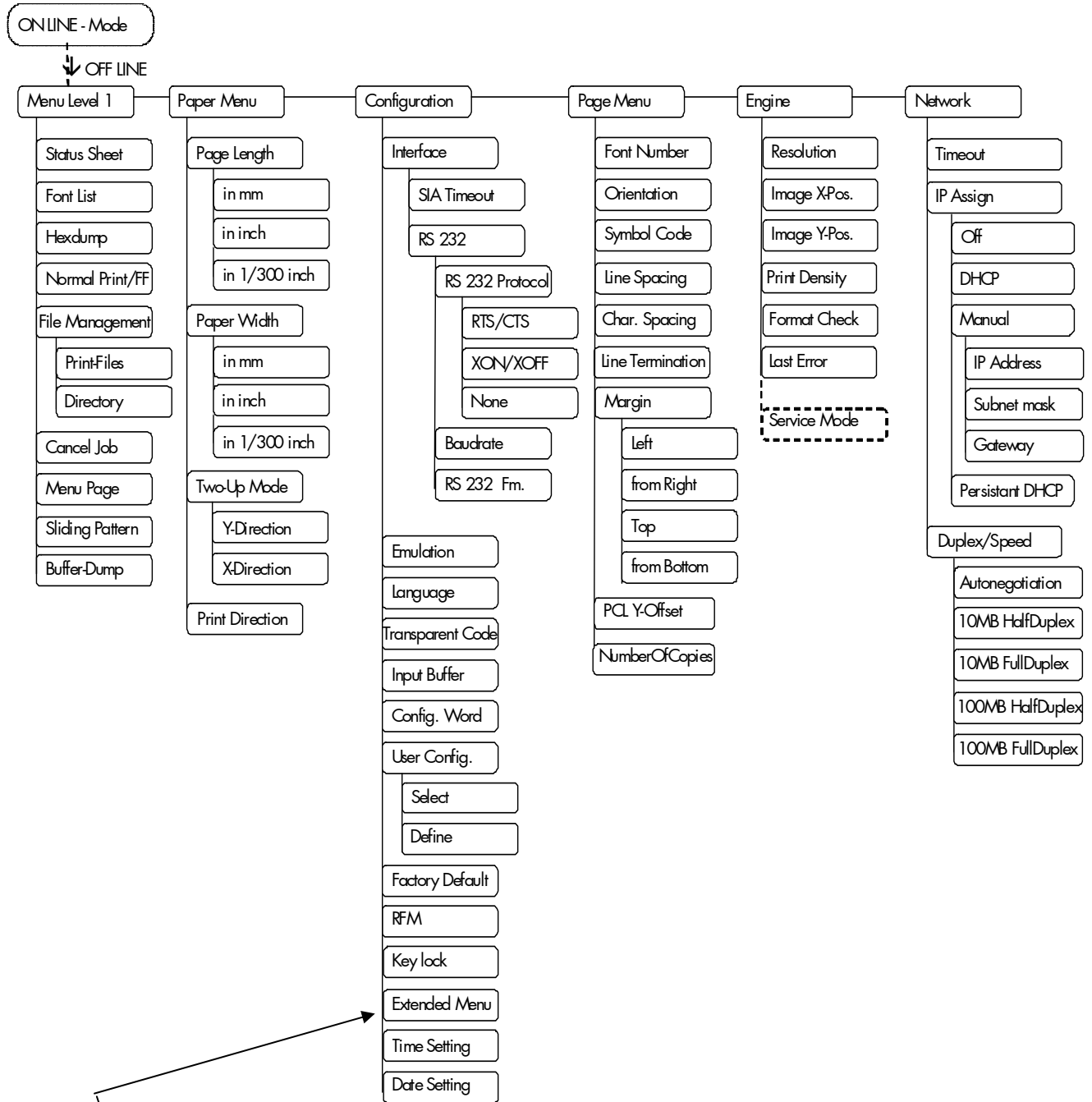

This panel function allows the user to choose a **reduced menu** instead of the extended menu shown above.

Selecting positions in the menu structure:



This symbol shows the ON/OFF LINE key. You get automatically into the first menu level, if the printer is turned OFF LINE with this key.



These symbols show the ARROW keys. By pressing the UP arrow or the DOWN arrow you can move within the menu levels.



Press and hold the UP key to scroll forward or the DOWN key to scroll backward (to change numerical values, for example).

["Menu Level"]

Each menu item/sub-item within a menu level is shown in the display of the control panel.



The SAVE key has two main functions. It gives the user access to a particular menu and, once in the menu, it allows the user to select a particular function.

["Function"]

Functions / Changing of function values:

Within one function the value can be changed by pressing the ARROW keys.



In case of a multi-digit function value the value of the currently chosen digit will be changed.



In case of a multi-digit function value pressing the SAVE key switches to the next position of the function value.



Pressing the MENU key switches to the previous digit of the function value.

Please note: If you press the MENU key although the absolute left digit of the function value is still arrived, the changing procedure will be cancelled and this moves you to the next menu level above.

If you press the SAVE key although the absolute right digit (digit 1) of the function value is still arrived, the currently displayed function value is stored.



Pressing the SAVE key the currently displayed function value is confirmed respectively the displayed function is activated. The changes are stored temporary. (This means, the changes are saved only until the next printer power off).

[Save as Setup?]

After this you have to decide, if you want to save the changes permanent (Save as setup).



To select such changes permanently, the user must press the SAVE key one more time. These permanent changes in printer configuration are active each time the printer is turned on again.



If the MENU key is pressed instead, the changes are only stored temporary (not saved as setup). (This key takes the user to the respective previous menu level).

Return to the menu level above:

Pressing the MENU key takes the user back to the respective menu level above.

Return to the ON LINE mode:

Pressing the ON LINE key switches the user directly to "ON LINE" from any menu position.

4.7. Syntax of Diagrams

The control panel functions will be described using diagrams. These diagrams show the course necessary in order to activate a certain function.

First the elements of the diagrams are explained:

The sequence on the left describes which keys have to be pressed briefly in succession.

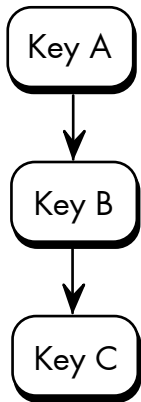

In this example key A has to be pressed first. Then key A is released and key B has to be pressed. Then key B has to be released and key C has to be pressed.

["Message"]

The "Panel display" column shows the display messages corresponding to the sequences listed on the left.

In the column "Notes" explanations to particular operational steps are given.





5. Panel Functions



For the panel functions described in the following, the printer is presumed to be turned on and in the ON LINE mode.

5.1. Printing the Status Sheet

This function generates a status sheet. The status sheet contains information about the current printer configuration and the available fonts.

	<u>Panel display</u>	<u>Notes</u>
	[SOLID 85E]	
	[Menu Level 1]	Turn the printer OFF LINE with this key.
		
↓		
		Press the SAVE key. Menu level 1 is selected.
↓		
	[Status Sheet]	Press the SAVE key again.
↓		
	[Status Sheet]	A status sheet is printed.
		The printer is turned ON LINE again.

Status sheet contents:

The first lines, entitled SERVICE INFORMATION, contain hexadecimal coded configuration parameters.





Printed in plain text:

- Controller version / memory / serial number
- Firmware release
- Interface
parameters of Parallel, Serial, USB, Network (Ethernet)
- Network
parameters and addresses
- Printer emulation
- User-RAM / free User-RAM
- Input data buffer
- Transparent code
- Paper size
- Default margins top / left
 bottom / right
- Default character code
- Options
- Fonts installed (Font banks)

Note: Use the panel function Printing the Font List to show the fonts installed (see the following section).

5.2. Printing the Font List









This function generates a list of all fonts installed to the printer. The font list shows demo prints of all fonts and, in addition, the concerning PCL selection commands. These commands contain information on font width and font height (see section 5.19 Font Selection, too).

	<u>Panel display</u>	<u>Notes</u>
	[SOLID 85E]	
		Turn the printer OFF LINE with this key.
↓		
	[Menu Level 1]	Menu Level 1 is selected.
↓		
	[Status Sheet]	Press one of the ARROW keys until [Font List] is displayed.
↓	...	
	[Font List]	The font list is printed.
		
↓		
	[Font List]	The printer is turned ON LINE again.

5.3. Choosing Print Resolution

This function allows the user to choose the current print resolution.

If, after a particular resolution is chosen, the print data stream indicates a different resolution (e.g. via a WINDOWS print driver), the second print resolution will be used only for that job.

<u>Panel display</u>	<u>Notes</u>
	
↓	
	
↓	
...	
	
↓	
	
↓	
	
↓	
...	
	
↓	
	
↓	
	
<p>[SOLID 85E]</p> <p>[Menu Level 1]</p> <p>...</p> <p>[Engine]</p> <p>[Resolution]</p> <p>[300 dpi]</p> <p>...</p> <p>[600 dpi]</p> <p>[Save as Setup?]</p>	<p>Turn the printer OFF LINE with this key.</p> <p>Press one of the ARROW keys until [Engine] is displayed.</p> <p>Menu item Engine is selected.</p> <p>Menu item Resolution is selected.</p> <p>Press one of the ARROW keys until the desired Resolution (e.g. 600 dots per inch) is displayed.</p> <p>600 dpi resolution is selected.</p> <p>In addition this new value can be saved as setup value (using the SAVE key), before the printer is turned ON LINE again.</p>





Remarks on choosing print resolution (Fonts):

By selecting 300 dpi resolution the printing system will be compatible for all applications (300 dpi data stream), also the 300 dpi font banks (bitmap writing) are available.

If 600 dpi resolution is chosen, the corresponding fonts must be loaded into the printer server (e.g. True Type fonts, scalable download fonts).

5.4. Hexdump Mode Activation





Within the Hexdump Mode the printer prints all characters received via interface without any interpretation (hexadecimal coded). This mode helps with error diagnosis. The Hexdump Mode can be activated only temporarily.

	<u>Panel display</u>	<u>Notes</u>
	[SOLID 85E]	
		Turn the printer OFF LINE with this key.
↓		
	[Menu Level 1]	Menu level 1 is selected.
↓		
	[Status Sheet]	Press one of the ARROW keys until [Hexdump] is displayed.
↓	...	
	[Hexdump]	
		The Hexdump Mode is activated.
↓		
	[Hexdump]	The printer is turned ON LINE again.

Note: By activating the normal print mode (see next section) or by turning the printer off and on again the printer can be taken out of Hexdump Mode. Time between turning the printer off and on again should be at least 15 seconds.

5.5. Normal Print Mode Activation (incl. FORM FEED)





The normal print mode suspends the Hexdump Mode. This function is activated, when a print job must be continued without turning the printer off and on again. In addition to that the function "Normal Print Mode Activation" is used to produce a FORM FEED.

	<u>Panel display</u>	<u>Notes</u>
	[SOLID 85E]	Turn the printer OFF LINE with this key.
↓		
	[Menu Level 1]	Menu level 1 is selected.
↓		
	[Status Sheet]	Press one of the ARROW keys until [Normal Print/FF] is displayed.
↓	...	
	[Normal Print/FF]	
	[Normal Print/FF]	The normal print mode is activated.
↓		
		The printer is turned ON LINE again.

Note: After activating the normal print mode a FORM FEED is released automatically and one sheet is put out. This is necessary because after a test in the Hexdump Mode it is possible that data can remain in the input buffer unintentionally (cause: in the Hexdump Mode no control characters are evaluated and no FORM FEED is effected).

5.6. Clearing the Input Buffer (Cancel Job)





This function permits the resumption of a print job at a particular page after a print interruption (e.g. paper jam). The data contained in the input buffer before the interruption are cleared.

	<u>Panel display</u>	<u>Notes</u>
	[SOLID 85E]	
		Turn the printer OFF LINE with this key.
↓		
	[Menu Level 1]	Menu level 1 is selected.
↓		
	[Status Sheet]	
↓		
	...	Press one of the ARROW keys until [Cancel Job] is displayed.
	[Cancel Job]	
		All data contained in the input buffer will be cleared.
↓		
	[Cancel Job]	The printer is turned ON LINE again.

5.7. Printing the Menu Page

This function prints a survey of the available panel functions.

Note: When printing the menu page please use a large paper.

<u>Panel display</u>	<u>Notes</u>
	[SOLID 85E]
↓	
	[Menu Level 1]
↓	
	[Status Sheet]
↓	...
	[Menu Page]
↓	
	[Menu Page]

Turn the printer OFF LINE with this key.

Menu level 1 is selected.

Press one of the ARROW keys until [Menu Page] is displayed.



A menu structure presentation of the SOLID 85E (see section 4.6) is printed.

The printer is turned ON LINE again.

5.8. Generating Test Prints (Sliding Pattern)







This function generates a series of test prints without sending data to the printer.

These test prints facilitate error analysis.

	<u>Panel display</u>	<u>Notes</u>
	[SOLID 85E]	
↓		
	[Menu Level 1]	Turn the printer OFF LINE with this key.
↓		
	[Menu Level 1]	A status sheet is generated (possibly printed on several pages)
		The printer is turned ON LINE again.

Another way to activate the function:

see the following page !

	<u>Panel display</u>	<u>Notes</u>
	[SOLID 85E]	Turn the printer OFF LINE with this key.
↓		
	[Menu Level 1]	Menu level 1 is selected.
↓		
	[Status Sheet]	Press one of the ARROW keys until [Sliding Pattern] is displayed.
↓	...	
	[Sliding Pattern]	A series of test prints is generated.
↓		
	[Sliding Pattern]	The printer is turned ON LINE again.
	The printing out of test prints can be stopped by pushing the ON LINE key.	

5.9. Page Length Adjustment

After inserting new material (e.g. paper) this function is used to adjust the printer to the new page length. The default page length value is 12 inches for Europe, 11 inches for North America.

<u>Panel display</u>	<u>Notes</u>
	
↓	
[SOLID 85E]	
[Menu Level 1]	
...	
[Paper Menu]	
...	
[Stacker Select]	
...	
[Page Length]	
...	
[in Inch]	
...	
[Digit4 12.00]	
...	
[Digit1 12.33]	
...	
[Save as Setup?]	
...	
[ON LINE]	

Turn the printer OFF LINE with this key.

Press one of the ARROW keys until [Paper Menu] is displayed.

Press the SAVE key to select the paper menu.

Press one of the ARROW keys until [Page Length] is displayed.

Press the SAVE key to adjust the page length.

Inch = currently selected measuring unit (alternative the measuring units mm or 1/300 inch can be chosen with the ARROW keys).

Pressing one of the ARROW keys changes the value of the current position (Digit 4 = left digit, in this example: 1).

Pressing the SAVE key moves you to the next digit (the MENU key moves you back). Values from 7 to 24 inches are settable.

The page length is changed to 12.33 inches.

In addition this new value can be saved as setup value (using the SAVE key), before the printer is turned ON LINE again.

Note If the option '**Paper Request**' is chosen (by the following change of configuration: CONFIG 32: Bit 2 set to 1), the printer goes OFF LINE not only in case of paper end, but also after every printer turn on and after every paper size adjustment, too.
The panel display shows the message [Load Paper]
After loading the corresponding paper the printer is turned ON LINE by using the ON LINE key.

5.10. Selecting the Number of Printpages per Page Format (Two-Up Mode)

Activating this function determines the arrangement of several printpages per page format (paper width resp. page length).



Panel display

Notes

[SOLID 85E]

Turn the printer OFF LINE with this key.

[Menu Level 1]

Press one of the ARROW keys until [Paper Menu] is displayed.

...

[Paper Menu]

Press the SAVE key to select the paper menu.



[Stacker Select]

Press one of the ARROW keys until [Two-Up Mode] is displayed.

...

[Two-Up Mode]

Press the SAVE key to select the function Two-Up mode.



[Y-Direction]

Press one of the ARROW keys to effect the adjustment of the Two-Up mode to the X-direction (cross to the print direction).

...

[X-Direction]

Press the SAVE key to set the Two-Up mode.



[X-Direction: OFF]

By pressing the ARROW UP or DOWN key the number of print pages cross to the print direction can be altered. The maximum number of print pages being adjustable next to each other is 9.

...

[X-Direction: 2]

Here the number of print pages per format width was altered to 2.



[Save as Setup?]

In addition this new value can be saved as setup value (using the SAVE key), before the printer is turned ON LINE again.



Example:

The printer SOLID 85E processes fanfold paper with a width up to 18 inches (17" printable). When the Two-Up mode is chosen, each time 2 images of A4 are printed side by side.

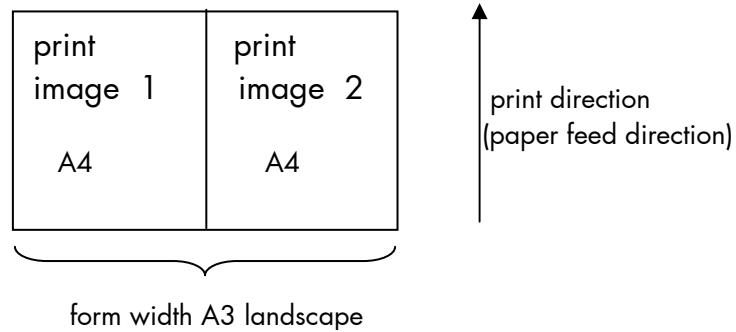









**Note:**

All other page parameters have to be set optionally in accordance to the requirements.

A simultaneous combination of several print images per formlength and several print images per form width isn't possible until now.

5.11. Paper Width Adjusting (Format Width)

This function is used to adjust the format width (print width) to the actually used paper format.

<u>Panel display</u>	<u>Notes</u>
	
↓	
	[SOLID 85E]
↓	[Menu Level 1]
...	...
	[Paper Menu]
↓	Press the SAVE key to select the paper menu.
	
↓	[Stacker Select]
	...
↓	[Paper Width]
	Press the SAVE key to adjust the format width to the paper width.
↓	[in inch]
	...
↓	[Digit4 08.51]
	Pressing one of the ARROW keys changes the value of the current position (Digit4 = left digit, in this example: 0). Pressing the SAVE key moves you to the next digit (the MENU key moves you back). The maximum adjustable format width is 14.72 inches.
↓	...
	[Digit1 08.53]
↓	The format width is changed to 8.53 inches.
	[Save as Setup?]
↓	In addition this new value can be saved as setup value (using the SAVE key), before the printer is turned ON LINE again.
	

Note: Information for „Paper Request“ can be found in section 5.9 Page Length Adjustment.

5.12. Print Direction Selection

This function selects the active print orientation (orientation of the whole printout including graphics, etc. on the paper).

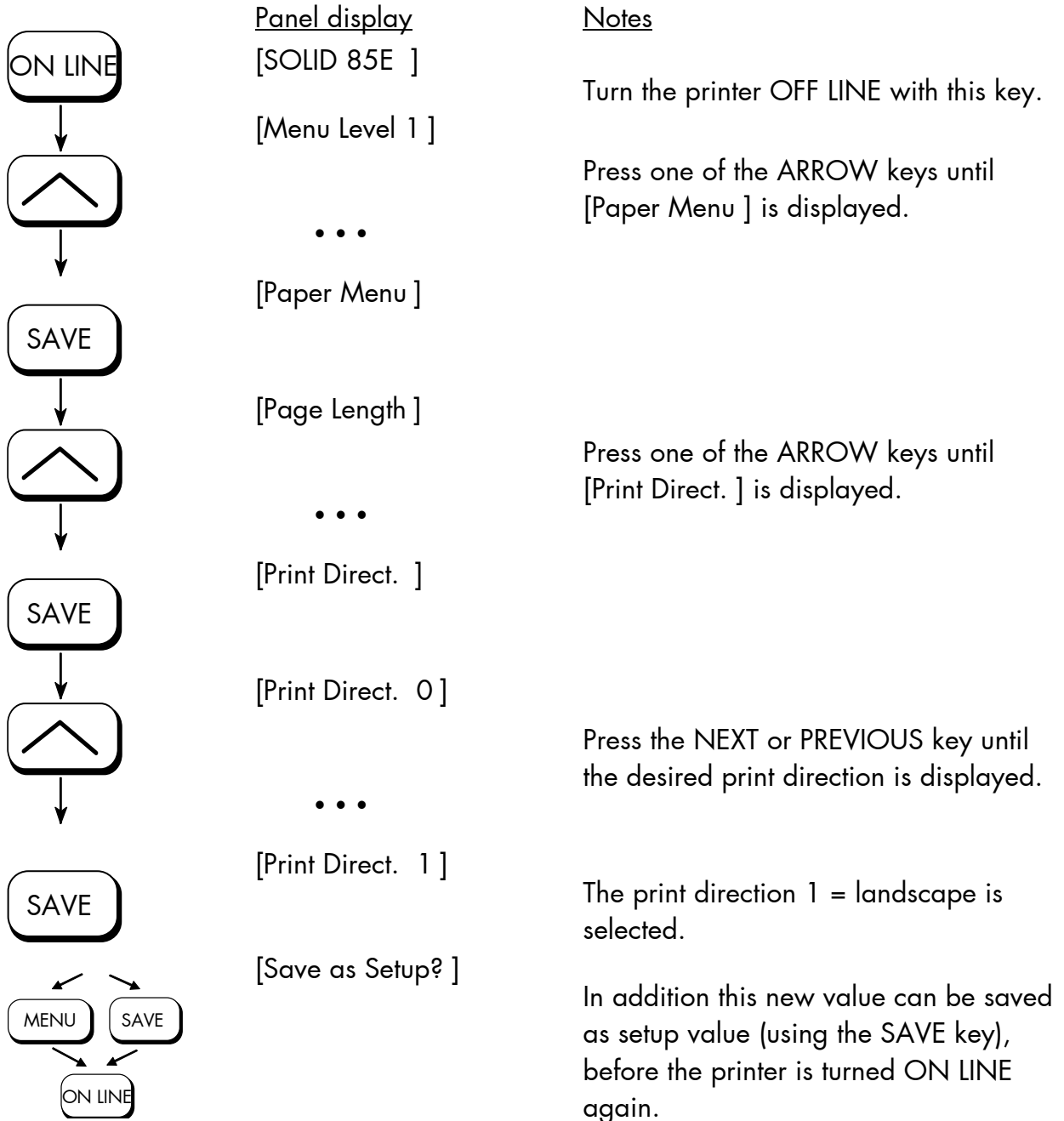

Turn the printer OFF LINE with this key.

Press one of the ARROW keys until [Paper Menu] is displayed.

Press one of the ARROW keys until [Print Direct.] is displayed.

Press the NEXT or PREVIOUS key until the desired print direction is displayed.

The print direction 1 = landscape is selected.

In addition this new value can be saved as setup value (using the SAVE key), before the printer is turned ON LINE again.

- Print direction assignment:
- Print direction 0 = Portrait (upright format)
 - Print direction 1 = Landscape (horizontal format)
 - Print direction 2 = Portrait upside down
 - Print direction 3 = Landscape upside down

5.13. Data Interface Configuration

This function is used to set the interface parameters.

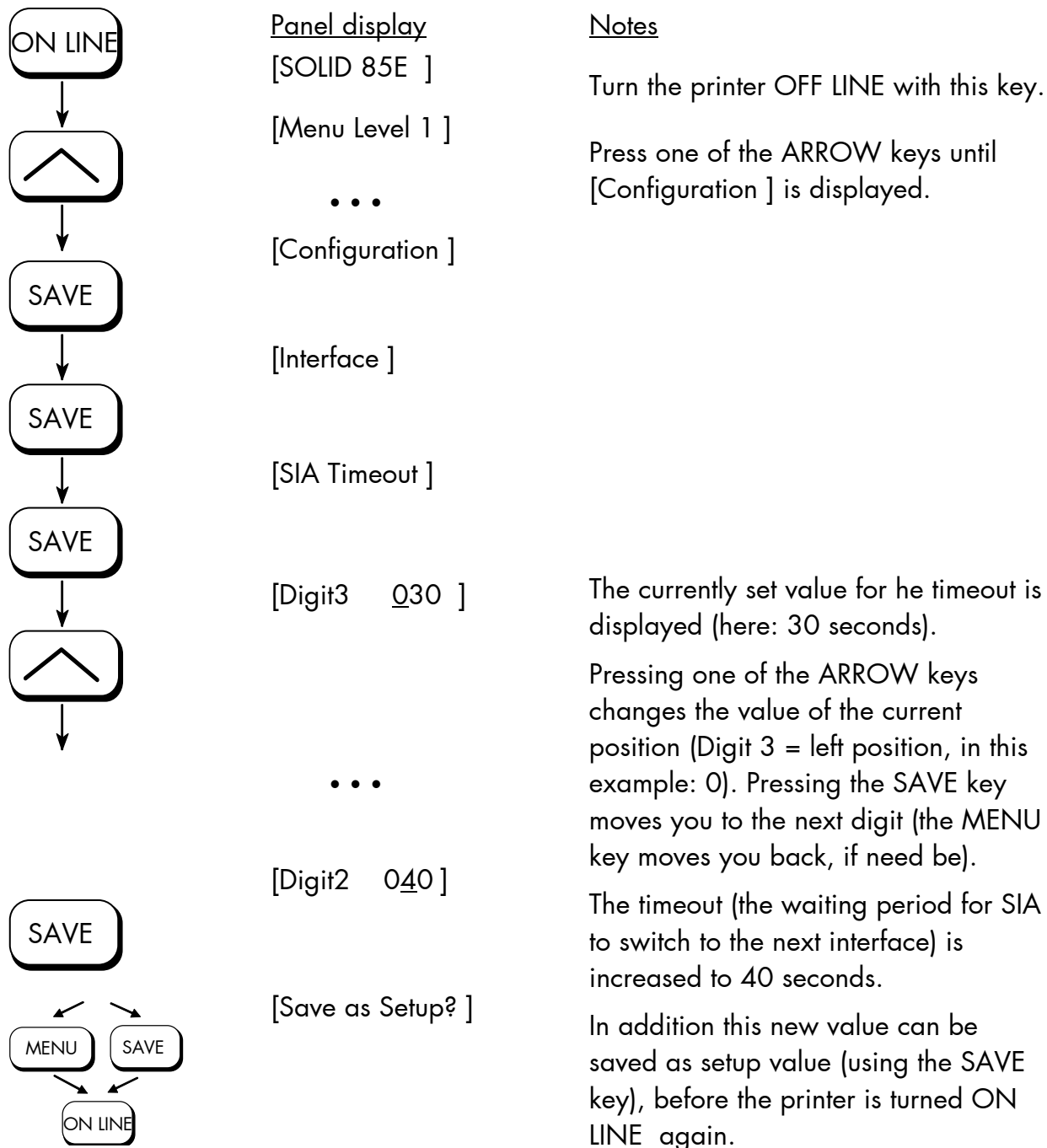







Note:

The printer uses SIA (Simultaneous Interface Administration) to check, which interface is currently used for the transfer of print data.

5.14. Emulation Selection

With this function you can change the active emulation.

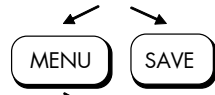
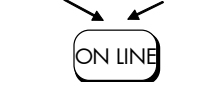
	<u>Panel display</u>	<u>Notes</u>
	[SOLID 85E]	Turn the printer OFF LINE with this key.
↓	[Menu Level 1]	Press one of the ARROW keys until [Configuration] is displayed.
	...	
↓	[Configuration]	
	[Interface]	
↓	...	Press one of the ARROW keys until [Emulation] is displayed.
	[Emulation]	
↓	[SOLID Standard]	
	...	Press one of the ARROW keys until the desired emulation (e.g. HP PCL 5) is displayed.
↓	[HP PCL 5]	
	[Save as Setup?]	The emulation HP PCL 5 is selected.
		In addition this new value can be saved as setup value (using the SAVE key), before the printer is turned ON LINE again.
		

Available emulations:

Standard:

MICROPLEX IDOL,
HP LaserJet (PCL 5),
Epson FX,
IBM Proprinter,
TIFF (CCITT group 4),
µPostscript

Optional:

Kyocera Prescribe,
Printronix IGP/PGL,
ZPL II (Zebra Programming Language),
Datamax (FGL),
Eltron EPL2,
Diablo 630,
AGFA Reno,
S3000 Lineprinter,
HPGL (7475A),
DEC LN03+,
Tally MT 6xx,
Bull MP6090,
IDS/IDS2,
QMS (Magnum) Code V,
ANSI Genicom,
XEROX XES,
HP DesignJet (HPGL-2),
LDC (Label Description Language),
Express









(More emulations on request)

Notice:

The brand names mentioned are registered trademarks of the enterprises named above.









5.15. Display Language Selection

This function enables the user to determine the language for the display messages, the status sheet and the font list.

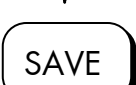
<u>Panel display</u>	<u>Notes</u>
	[SOLID 85E]
↓	[Menu Level 1]
	...
↓	[Configuration]
	[Interface]
↓	...
	[Language]
↓	[German]
	...
↓	[English]
	The display language English is selected.
	[Save as Setup?]
	In addition this new value can be saved as setup value (using the SAVE key), before the printer is turned ON LINE again.

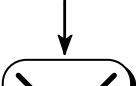
5.16. Transparent Code Adjustment

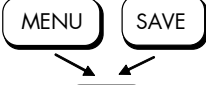
This function configures the transparent code. Using the transparent code enables you to initiate the commands of the page description language IDOL by **printable** characters. The transparent code pre-setting is 2625. These are the ASCII character codes (hexadecimal) for the characters &% (ref. IDOL Programming Manual).

<u>Panel display</u>	<u>Notes</u>
	
↓	
	[SOLID 85E]
↓	[Menu Level 1]
	...
↓	[Configuration]
	
↓	[Interface]
	...
↓	[Transparent Code]
	[Digit4 2625]
↓	
	...
↓	[Digit1 262 <u>6</u>]
	
↓	[Save as Setup?]
	
	

Notes

Turn the printer OFF LINE with this key.

Press one of the ARROW keys until [Configuration] is displayed.

Press one of the ARROW keys until [Transparent Code] is displayed.









The hexadecimal numbers for &% are preset. Pressing one of the ARROW keys changes the value of the current digit (Digit4 = left position, in this example: 2). Pressing the SAVE key moves you to the next digit (the MENU key moves you back).

2626 is selected as transparent code. From now on use the characters && before programming the IDOL commands.

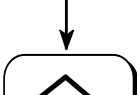
In addition this new value can be saved as setup value (using the SAVE key), before the printer is turned ON LINE again.

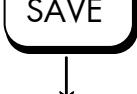
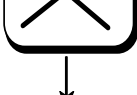



5.17. Selection of Memory Distribution (Input Buffer)

This function enables the user to choose the distribution of the available RAM memory between input buffer and macro/download memory.

<u>Panel display</u>	<u>Notes</u>
	[SOLID 85E]
	Turn the printer OFF LINE with this key.
	[Menu Level 1]
	Press one of the ARROW keys until [Configuration] is displayed.
	...
	[Configuration]
	Press one of the ARROW keys until [Input Buffer] is displayed.
	[Interface]
	[Input Buffer]
	...
	[Input Buffer]
	[32 kB]
	Press one of the ARROW keys until the desired memory distribution is displayed. The input buffer size is specified in kilobyte (kB) or in percent of the installed memory.
	...
	[100 kB]
	100 kB is selected as input buffer.
	[Save as Setup?]
	In addition this new value can be saved as setup value (using the SAVE key), before the printer is turned ON LINE again.



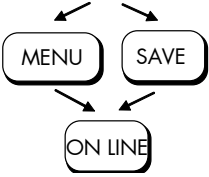

5.18. Setting to Factory Default

This function back-outs all configurations to factory defaults.

<u>Panel display</u>	<u>Notes</u>
	
↓	
	[SOLID 85E]
↓	[Menu Level 1]
↓	...
	[Configuration]
↓	[Interface]
	...
↓	[Factory Default]
	[Save as Setup?]
	Only if you press the SAVE key a second time the configuration will be back-outed to factory defaults.
	The printer is turned ON LINE again.

5.19. Font Selection

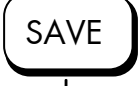
This function selects the active font. Select font number out of the list of available fonts.

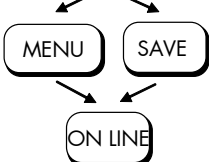
<u>Panel display</u>	<u>Notes</u>
	[SOLID 85E]
↓	Turn the printer OFF LINE with this key.
	[Menu Level 1]
↓	Press one of the ARROW keys until [Page Menu] is displayed.
↓	...
	[Page Menu]
↓	[Font Number]
	[Font 0600]
↓	Press one of the ARROW keys until the desired font number (5507 Langeoog e.g.) is displayed.
	...
↓	[Font 5507]
	The font number 5507 is selected.
↓	[Save as Setup?]
	In addition this new value can be saved as setup value (using the SAVE key), before the printer is turned ON LINE again.

The **SOLID 85E standard equipment** contains the following **fonts**:

<u>Font no.</u>	<u>Font width</u>	<u>Font height</u>	<u>Font name</u>
0600	10	12	Kurilen
0602	10	12	Kurilen Italic
0610	12	10.1	Kurilen
1710	12	10.1	Kurilen Italic
4508	P	8.1	Helgoland
4510	P	10	Helgoland
4714	P	14.4	Helgoland Bold
5507	20	7	Langeoog
5508	16.6	7.9	Langeoog
5509	15	9.1	Langeoog
6610	10	10.1	Juist Monosp.
9210	P	10.1	Tasmanien
9310	P	10.1	Tasmanien Italic
2000	P	SC	Tasmanien
9900	P	SC	Neuwerk

Resumption of this standard font list see next page.

Explanations:

Font width:

Character distance in CPI (Characters Per Inch).

P = proportional, (meaning that each character has an individual width).

Font height:

Font height from the lowest descender to the upper edge of the highest character, measured in graphical points (1/72 inch).

SC = scalable.

	<u>Font no.</u>	<u>Font width</u>	<u>Font height</u>	<u>Font name</u>
	0050	SC		Plakatschrift
	0590	SC		OCR /B
	0591	SC		OCR /A
	6600	SC		Juist Monospaced
PCL 5 compatible	0699	SC		Kurilen
	1700	SC		Kurilen Italic
	1800	SC		Kurilen Bold
	1900	SC		Kurilen Bold Italic
	5500	SC		Langeoog
	5600	SC		Langeoog Bold
	5700	SC		Langeoog Italic
	5800	SC		Langeoog Bold Italic
	2100	P	SC	Texel Bold
	2200	P	SC	Texel Italic
	2300	P	SC	Texel Bold Italic
	9800	P	SC	Neuwerk Italic
	9500	P	SC	Neuwerk Bold Italic
	9600	P	SC	Neuwerk Bold
	0060	SC		Plakatschrift
	9501	P	SC	Neuwerk-II Condensed Italic
	9601	P	SC	Neuwerk-II Condensed Bold Ital.
	9801	P	SC	Neuwerk-II Condensed Bold
	9901	P	SC	Neuwerk-II Condensed
	0530	P	SC	PiktoWin
	5100	P	SC	Amrum
	5200	P	SC	Amrum Bold
	5300	P	SC	Amrum Italic
	7500	P	SC	Antigua
	7700	P	SC	Antigua Bold
	7800	P	SC	Antigua Italic
	7900	P	SC	Antigua Bold Italic
	9199	P	SC	Tasmanien-II Bold Italic
	9299	P	SC	Tasmanien-II
	9399	P	SC	Tasmanien-II Italic
9499	P	SC	Tasmanien-II Bold	

Notes: Additional fonts can be selected from the font catalogue depending upon the memory capacity.

You can use the panel function Printing the Font List (see section 5.2) to generate a list of all fonts installed to the printer.

5.20. Text Orientation Selection

This function selects the active text orientation.

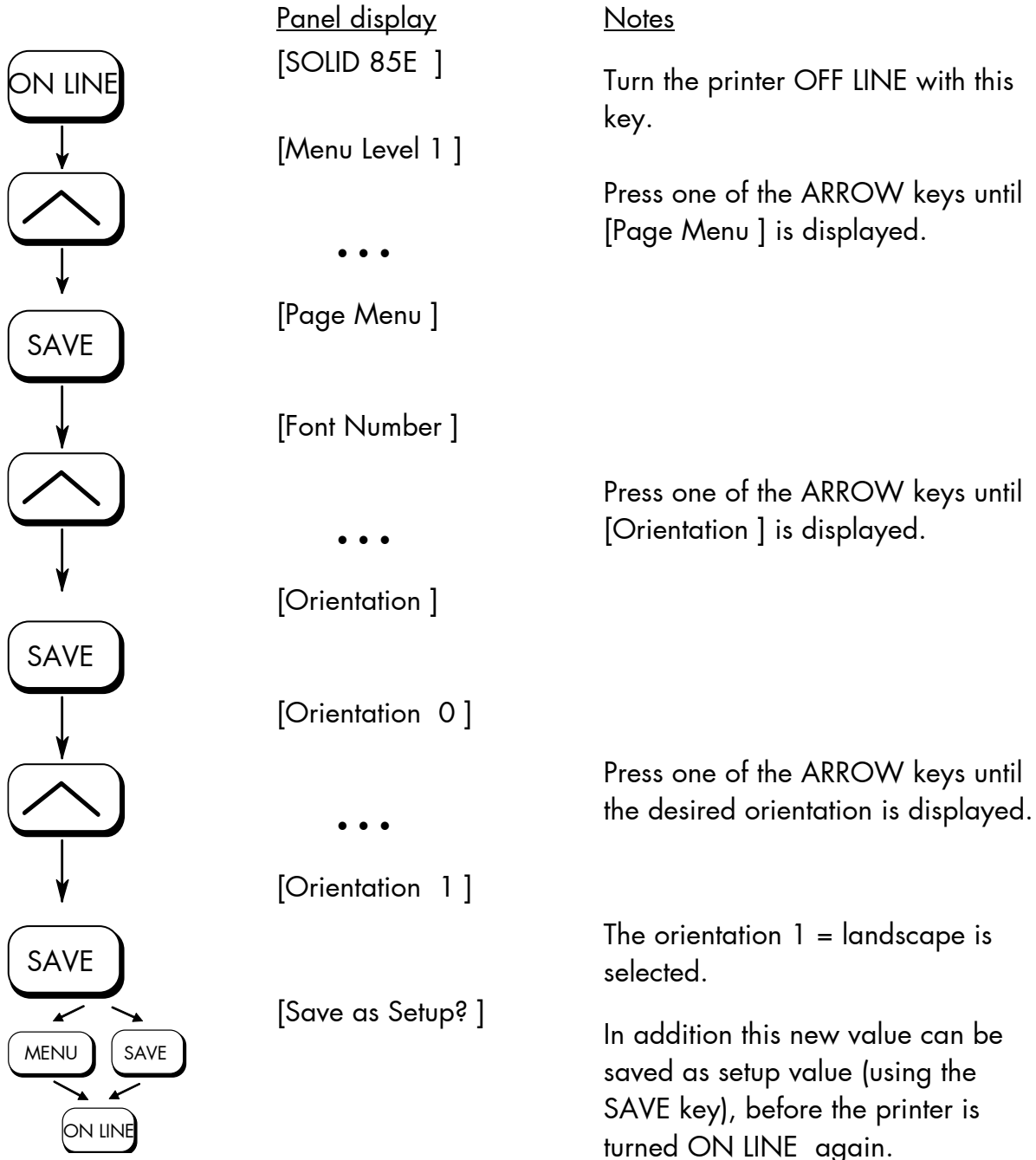









Text orientation assignment:

- Orientation 0 = Portrait (upright format)
- Orientation 1 = Landscape (horizontal format)
- Orientation 2 = Portrait upside down
- Orientation 3 = Landscape upside down

5.21. Symbol Code Selection

This function selects the active symbol code.

	<u>Panel display</u>	<u>Notes</u>
	[SOLID 85E]	Turn the printer OFF LINE with this key.
↓	[Menu Level 1]	
	...	Press one of the ARROW keys until [Page Menu] is displayed.
↓	[Page Menu]	
	[Font Number]	Press one of the ARROW keys until [Symbol Code] is displayed.
↓	...	
	[Symbol Code]	Press one of the ARROW keys until the desired symbol code is displayed.
↓	[902, IBM PC-II]	
	...	The symbol code 901, IBM PC-I is selected.
↓	[901, IBM PC-I]	
	[Save as Setup?]	In addition this new value can be saved as setup value (using the SAVE key), before the printer is turned ON LINE again.
		
		

5.22. Configuration of Text Margins

This function sets text margins. Margins are expressed in dots at the concerning edge of the paper.

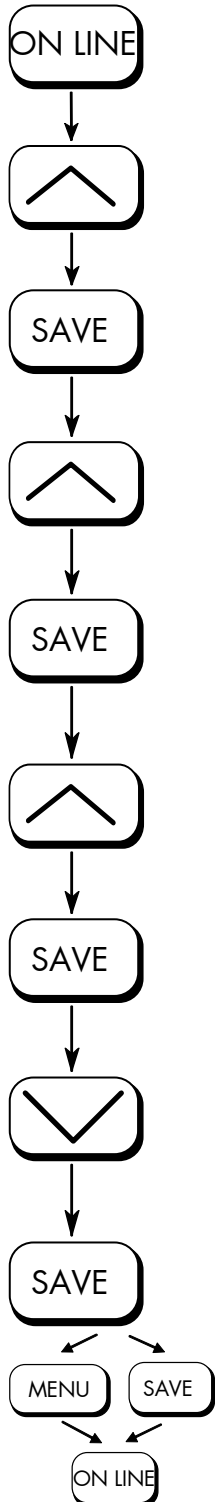

Panel display
[SOLID 85E]

Notes

Turn the printer OFF LINE with this key.

[Menu Level 1]

Press one of the ARROW keys until [Page Menu] is displayed.

...

[Page Menu]

[Font Number]

Press one of the ARROW keys until [Margin] is displayed.

...

[Margin]

[Left]

Press one of the ARROW keys until the desired margin is displayed.

...

[from Right]

[Digit4 0089]

Pressing one of the ARROW keys changes the value of the current digit (Digit 4 = left position, in this example: 0). Pressing the SAVE key moves you to the next digit (the MENU key moves you back).

...

[Digit1 008Z]

The right margin is changed into 87 dot.

[Save as Setup?]

In addition this new value can be saved as setup value (using the SAVE key), before the printer is turned ON LINE again.

5.23. Image Shifting to the X-Direction

This function shifts the print image in relation to the paper to the X-direction (crosswise the print direction). Because the paper feed is always centered to the middle in the SOLID 85E, the image shifting might be necessary when using e.g. special paper formats to shift the X-coordinate zero to the left paper edge.

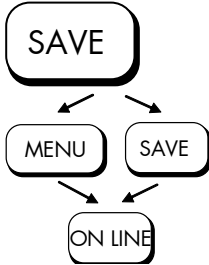



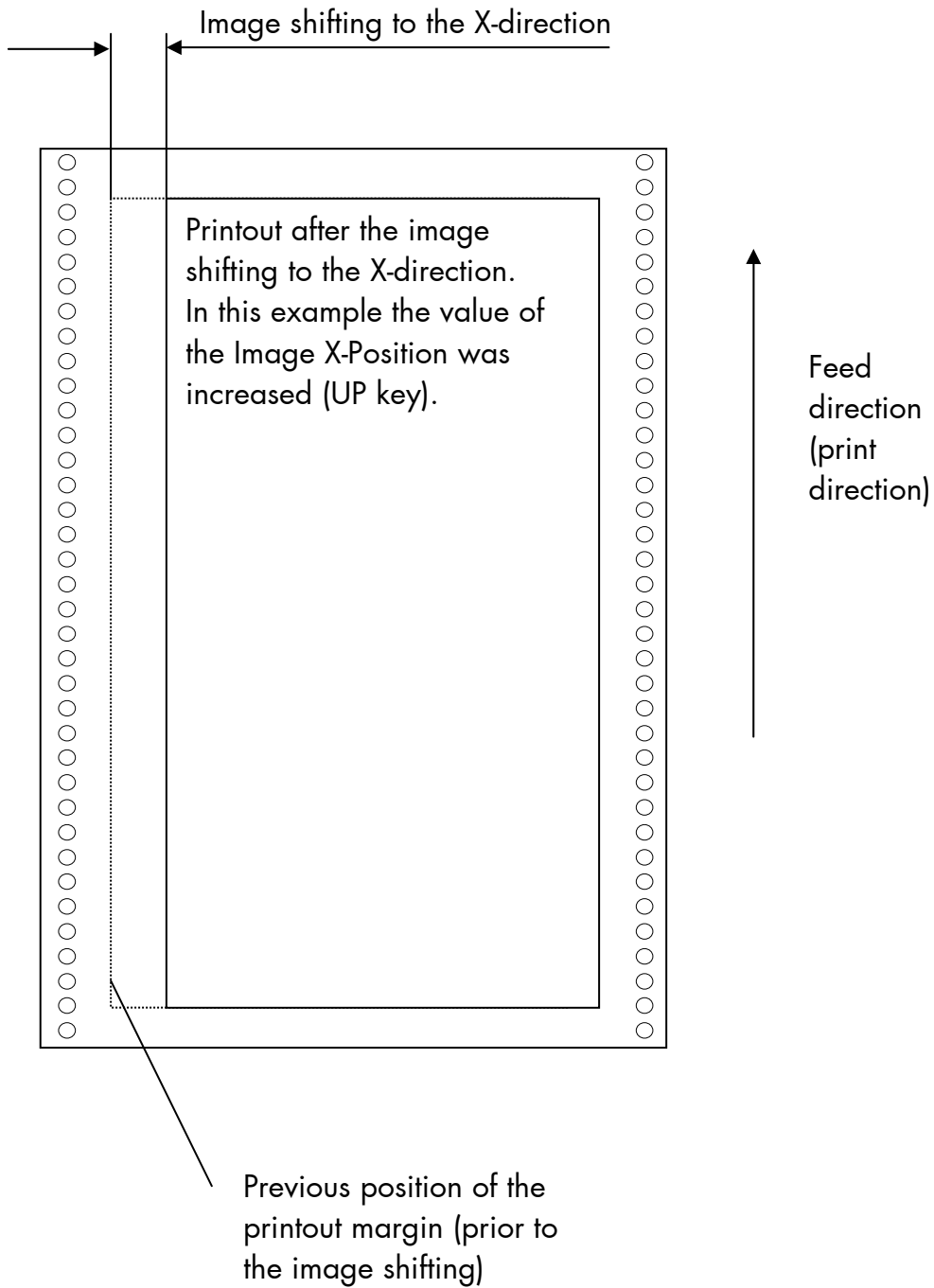





<u>Panel display</u>	<u>Notes</u>
ON LINE	
↓	
[SOLID 85E]	
[Menu Level 1]	
...	
[Engine]	Turn the printer OFF LINE with this key.
↓	
SAVE	
↓	
[Resolution]	
...	
[Image X-Pos.]	Press one of the ARROW keys until [Image X-Pos.] is displayed.
↓	
SAVE	The panel function Image Shifting to the X-Direction is selected.
↓	
[Image X-Pos. xxx]	xxx = currently set value. (Default value = 128).
↓	
[Image X-Pos. xxx]	Operating one of the ARROW keys the value for the image shift can be altered. Values from 0 up to 254 are settable, so a max. image shifting of appr. ±1 ¼ Inch (approx. ±32 mm) can be reached.
...	
[Image X-Pos. 160]	
↓	
[Save as Setup?]	Now the new image X-Position is saved
	In addition this new value can be saved as setup value (using the SAVE key), before the printer is turned ON LINE again.

Example for shifting the image to the X-direction:



5.24. Image Shifting to the Y-Direction

This function shifts the print image in relation to the paper to the Y-direction (print direction).

<u>Panel display</u>	<u>Notes</u>
	
↓	
	[SOLID 85E]
↓	[Menu Level 1]
↓	...
	[Engine]
↓	[Resolution]
↓	...
	[Image Y-Pos.]
↓	[Image Y-Pos. yyy]
	
↓	...
	[Image Y-Pos. 190]
↓	[Save as Setup?]
	
 	
	

Turn the printer OFF LINE with this key.

Press one of the ARROW keys until [Engine] is displayed.

Press one of the ARROW keys until [Image Y-Pos.] is displayed.

The panel function Image Shifting to the Y-Direction is selected.

yyy = currently set value.
(Default value = 128).

Operating the ARROW keys the image can be shifted relative to the paper. Values from 0 up to 254 are settable, so a max. image shifting of approx. ± 1 ¼ Inch (approx. ± 32 mm) can be reached.

Now the new image Y-Position is saved.





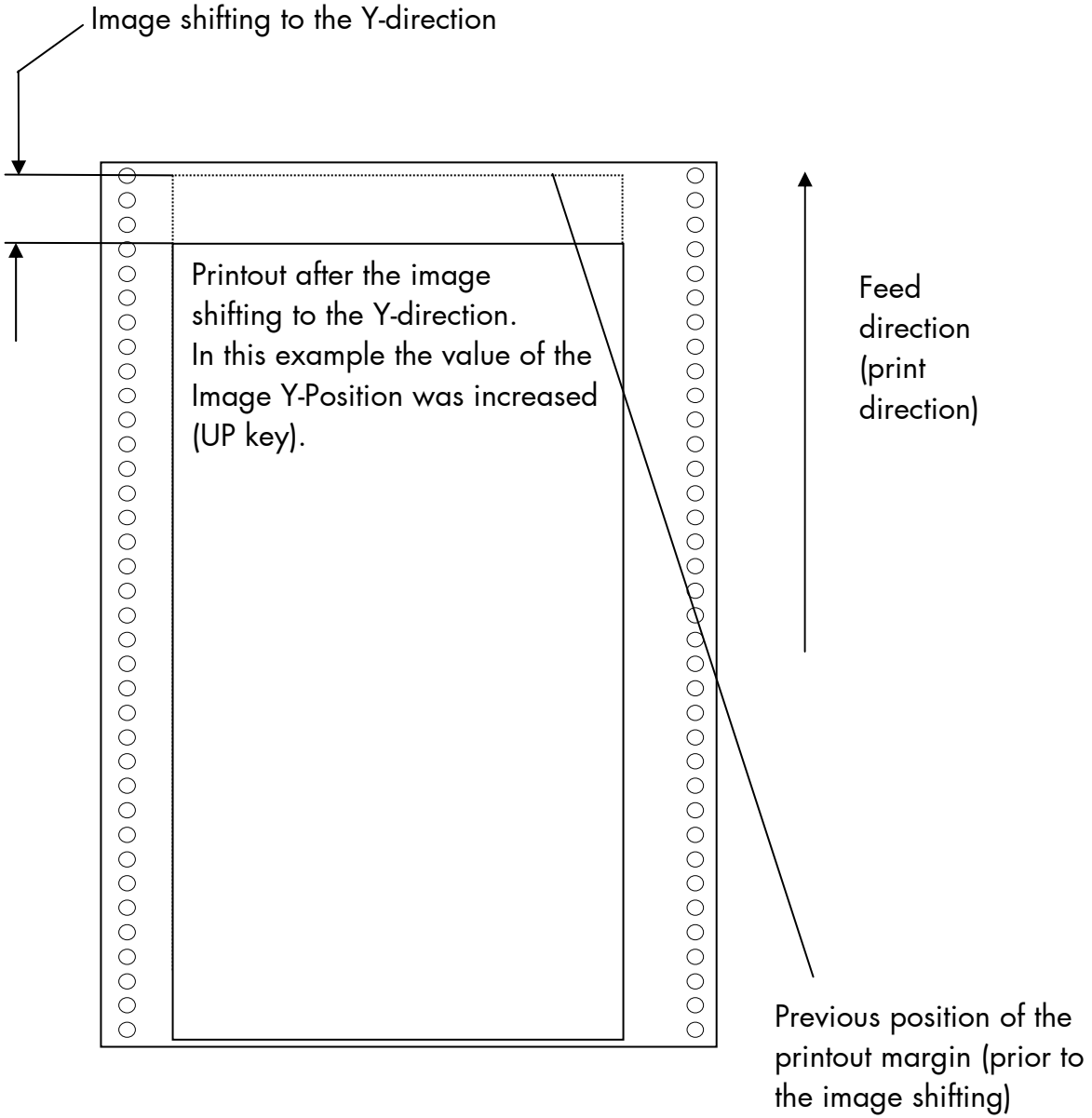

In addition this new value can be saved as setup value (using the SAVE key), before the printer is turned ON LINE again.

Example for shifting the image to the Y-direction:

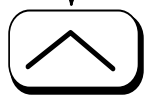

5.25. Lines per Inch Setting (Line Spacing)

This function sets the number of lines per inch. This setting is effective only in case of using the printer as a line printer. With a small number of lines per inch, line spacing will be relatively large. (Ref. IDOL Programming Manual).

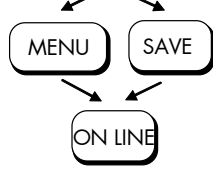
<u>Panel display</u>	<u>Notes</u>
	[SOLID 85E]
↓	[Menu Level 1]
	...
↓	[Page Menu]
	[Font Number]
↓	...
	[Line Spacing]
↓	[Digit4 006.5]
	6.5 lpi = currently set value. (lines per inch).
↓	Pressing one of the ARROW keys changes the value of the current digit (Digit 4 = left position, in this example: 0). Pressing the SAVE key moves you to the next digit (the MENU key moves you back).
	...
↓	[Digit1 010.0]
	The number of lines per inch was increased to 10 lpi.
↓	[Save as Setup?]
	In addition this new value can be saved as setup value (using the SAVE key), before the printer is turned ON LINE again.





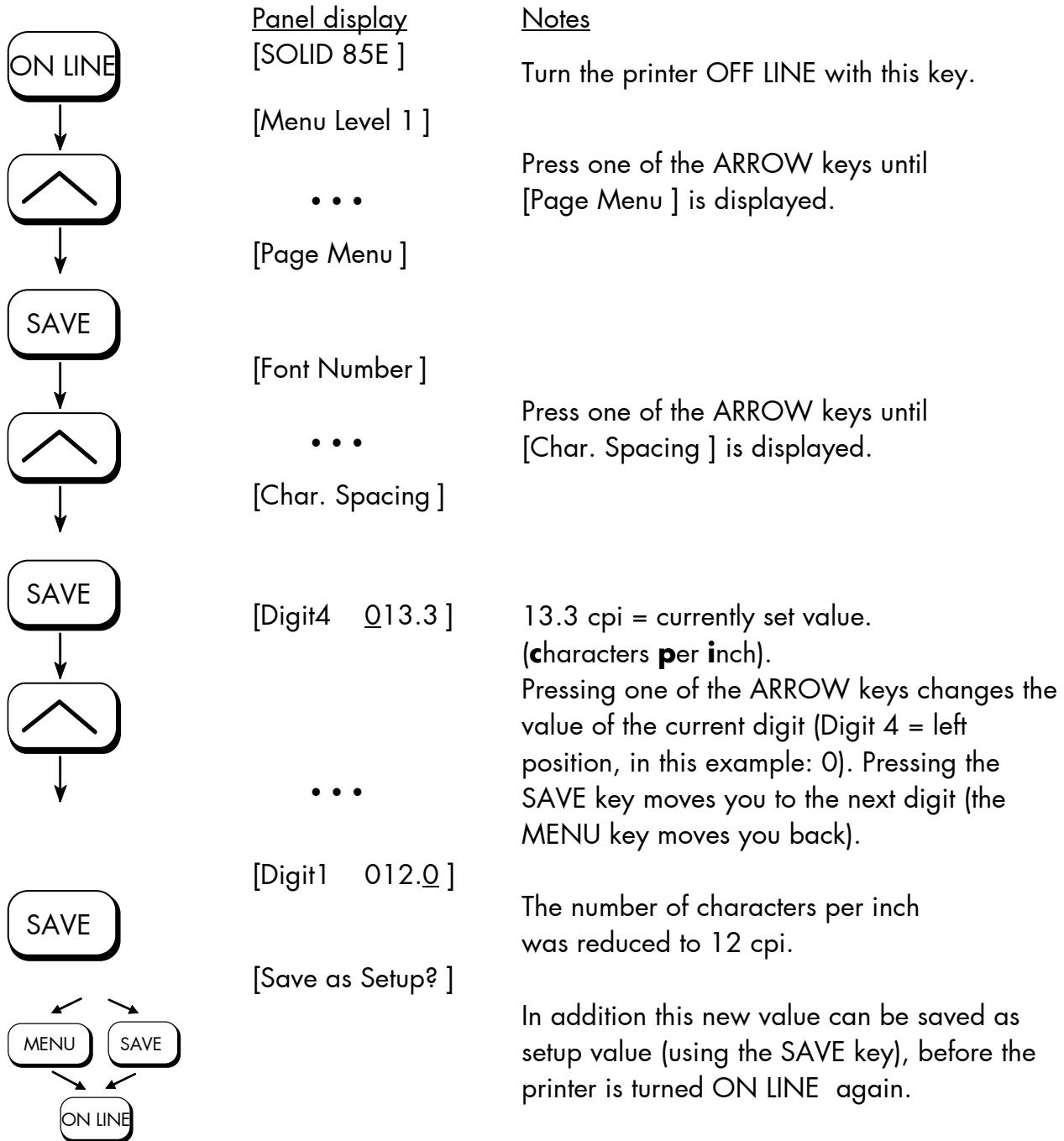

5.26. Number of Characters per Inch Setting (Character Spacing)

This function sets the number of characters per inch. This setting is effective only in case of using a line printer emulation. With a small number of characters per inch, character spacing will be relatively large. (Ref. IDOL Programming Manual).



5.27. Print Density Setting



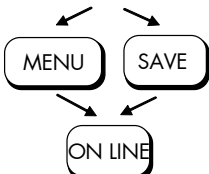



Using this function the density of the printed characters can be changed.

	<u>Panel display</u>	<u>Notes</u>
	[SOLID 85E]	Turn the printer OFF LINE with this key.
↓	[Menu Level 1]	
	...	Press one of the ARROW keys until [Engine] is displayed.
↓	[Engine]	
		
↓	[Resolution]	
	...	Press one of the ARROW keys until [Print Density] is displayed.
↓	[Print Density]	
		
↓	[Print Density 96]	96 = currently set value. (Default value = 88).
	...	Press one of the ARROW keys to change the density. Values from 0 up to 152 are settable.
↓	[Print Density 104]	
		The print density is increased, the print image gets darker. Now the new value is saved.
	[Save as Setup?]	In addition this new value can be saved as setup value (using the SAVE key), before the printer is turned ON LINE again.

5.28. Configuration of Network Parameters (IP Address, e.g.)

The functions of the submenu Network are used to set the parameters for connecting the printer to a network (Ethernet).

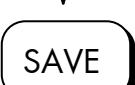
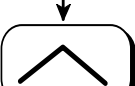
Setting the IP address manually:

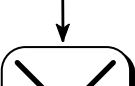
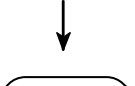
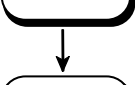
	<u>Panel display</u>	<u>Notes</u>
↓	[SOLID 85E]	Turn the printer OFF LINE with this key.
	[Menu Level 1]	Press one of the ARROW keys until
↓	...	[Network] is displayed.
	[Network]	Press the SAVE key to select the
↓	[Timeout]	Network menu.
	...	Press one of the ARROW keys until
↓	[IP Assign]	[IP Assign] is displayed.
		Press the SAVE key to select the
↓	[Off]	IP Assing menu.
	...	The current setting value is
↓	[Manual]	displayed.
		Press one of the ARROW keys until
↓	[IP Address]	[Manual] is displayed.
		Press the SAVE key to set the
↓	[192.168.002.002]	IP address manually.
	...	Pressing one of the ARROW keys
↓	[192.168.010.123]	changes the value of the current digit
		(left digit first, in this example: 1).
↓	[Saved !]	Pressing the SAVE key moves you to
		the next position (the MENU key moves
		you back, if need be).
		The new IP address is saved as setup
		value.
		The printer is turned ON LINE again.

Notes: If your network is using DHCP[Ⓢ], an address can be automatically assigned (select the item **DHCP** from the network submenu IP Assign).

The parameters **Subnet Mask** and **Gateway** are configured in the same way as described above. Please select the concerning panel functions for this (compare section 5.7 Menu Structure).

Select the subitem **Off** from the network menu to switch off the network access.

[Ⓢ] Dynamic Host Configuration Protocol: offers among other things a centralized address management.

Duplex/Speed Setting

This panel function is located in the network menu (submenu Duplex/Speed Setting).

The factory default value is Autonegotiation.

Autonegotiation means that devices on the network agree a transmission mode, which each unit is able to handle, before data transmission starts. By this the printer automatically adjusts itself to maximize link performance.

Hint: Autonegotiation is the recommended setting!

If you set the Duplex/Speed parameters manually, you may experience problems. Wrong settings can slow down the speed of the link (worst case: communication does not occur).

Explanations:

Auto-Negotiation

A Ethernet procedure that allows devices at either end of a link segment to advertise and negotiate modes of operation such as the speed of the link (100 Mbit/s or 10 Mbit/s) and half- or full-duplex operation.

Half duplex

A device can either receive or send data at a given time.

Full duplex

Capability of a device for sending and receiving data at the same time. In the case of full duplex, collision detection is deactivated. A full duplex capable device is able to buffer data packets.

6. Printer Cleaning

By a regular and conscientious performance of the following operations, the printer is guaranteed to always work at an optimum reliability.



After the printing of about 20,000 pages A4 (print density 5 %; compare chapter 10 Specifications) the components listed in this chapter should be cleaned.

Please note:

The printer is provided with a drum counter.

Although this counter only records the revolutions of the drum, the meter readings can be used to calculate values for the "number of pages". For every conversion you have to know the page length of the printjob and to consider the following: One digit of the counter corresponds to a page length of 14.8 inch, because this is the circumference of the drum.

Example: If 20,000 pages A4 portrait Two-Up have been printed the number shown by the counter is approx. 7,900.

- Use a neutral detergent or water on a lintfree cloth to remove dust or grease from the cover.
- Do not use detergents or any other devices or tools not mentioned in this manual to avoid damages and unnecessary costs of repairs.
- Please be especially careful to avoid damaging mechanical or electronic modules.



Turn off the SOLID 85E printer and pull the power plug. Make sure, the printer has been switched off for at least 15 minutes before you start cleaning.

6.1. Cleaning the Elements behind the Front Cover



1. Turn off the SOLID 85E printer and pull the power plug. Make sure, the printer has been switched off for at least 15 minutes before you start cleaning the device.
2. Open the front cover of the printer.

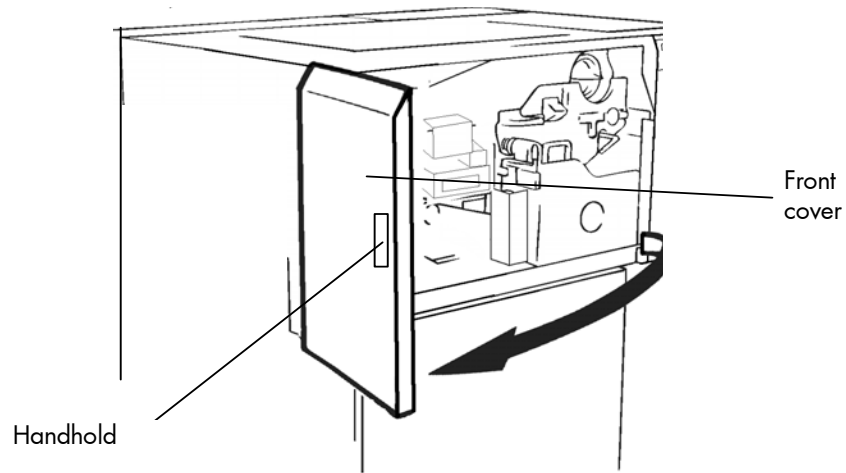

3. Using an anti-static service vacuum cleaner, clean up toner, paper dust or other particles which may have accumulated.
4. Push down the open lever of the waste toner recovery unit and open the unit.

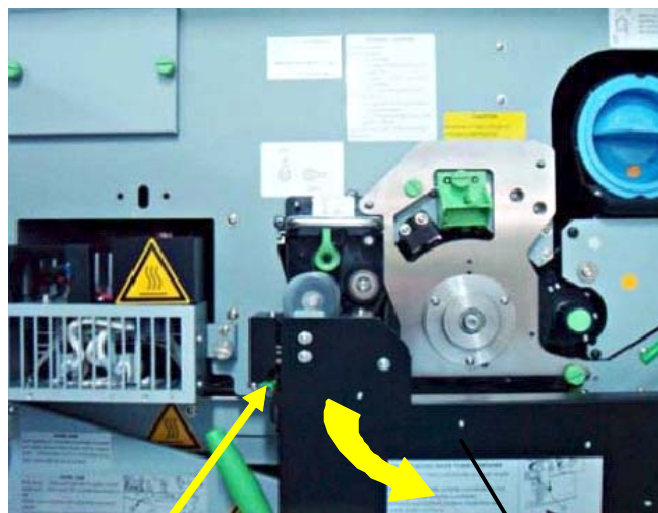

Open lever (green)

Waste toner recovery unit

- Using an anti-static service vacuum cleaner, pick up any dirt on the developer unit or toner cartridge.

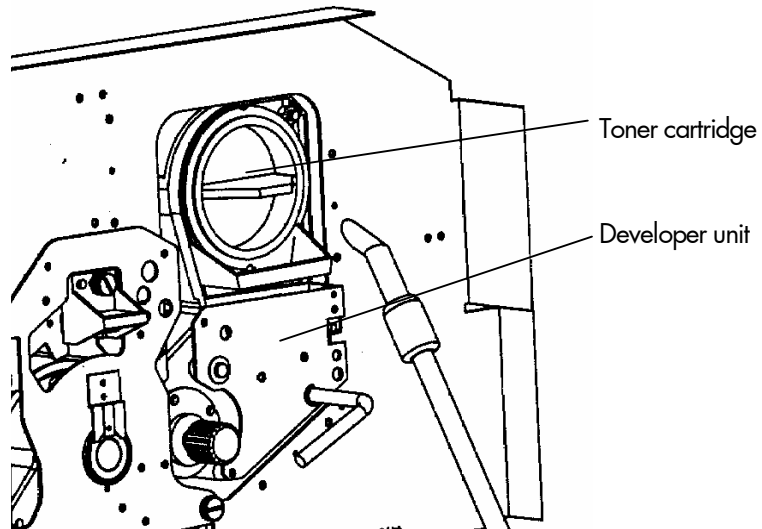

- Clean the drum cleaning unit and the elements around it in the same way.

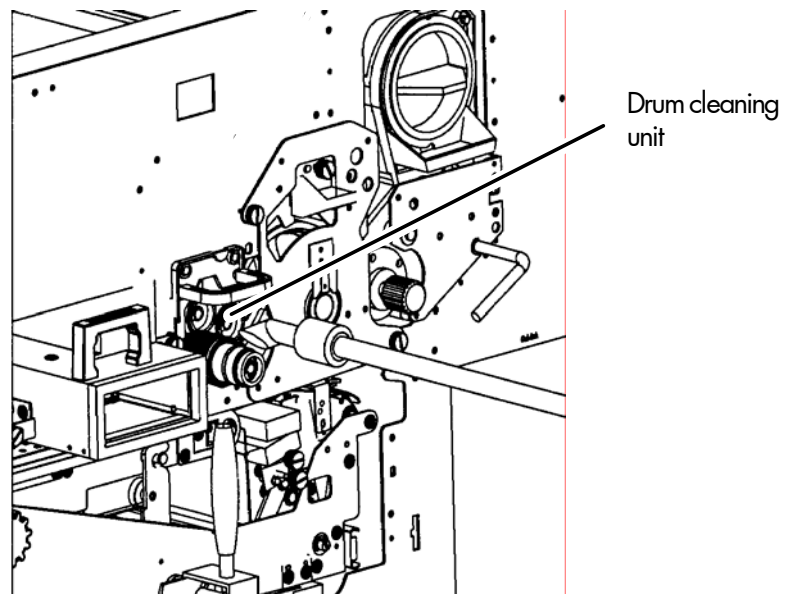

7. Loosen the knurled screws (see figure below) and then remove the dust filter cover.

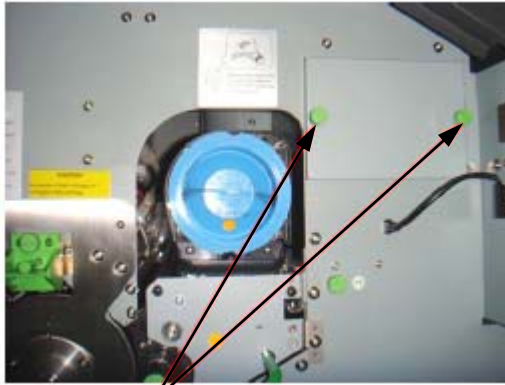

Knurled screws

8. Pull out the dust filter.



Dust filter

9. Use an anti-static service vacuum cleaner to clean the dust filter area.



10. Insert a new dust filter and reassemble the cover using the two knurled screws.

11. Also vacuum the fuser unit and the area around it.

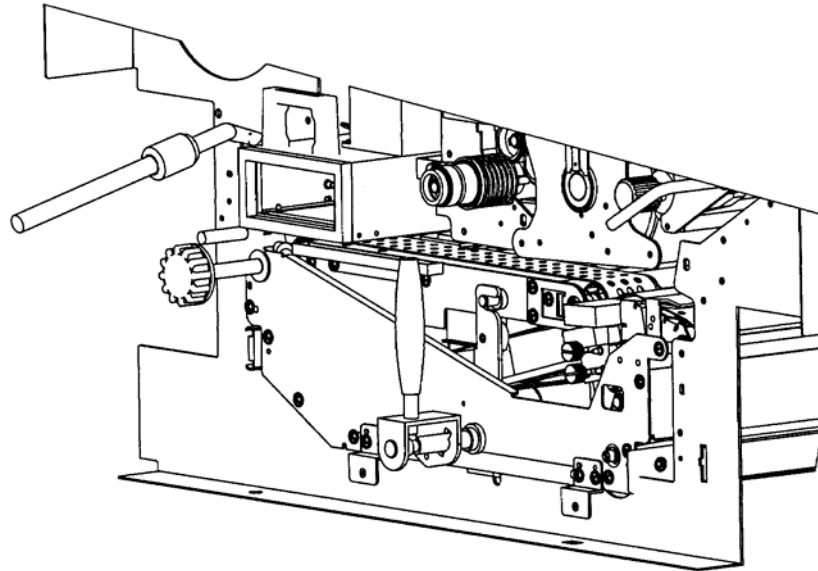

12. Close the waste toner unit.



Make sure the bar has engaged.

13. Close the printer's front cover.

6.2. Cleaning the Transport Unit



1. Turn off the SOLID 85E printer and pull the power plug. Make sure, the printer has been switched off for at least 15 minutes before you start cleaning the device.
2. Open the front cover of the printer.
3. Open the waste toner unit (compare previous section).
4. Press down the green lever of the transport unit. The transport path is set down by that.



5. Press down the lever while pulling the transport unit towards you to avoid damaging the printer. Pull the unit until it stops.

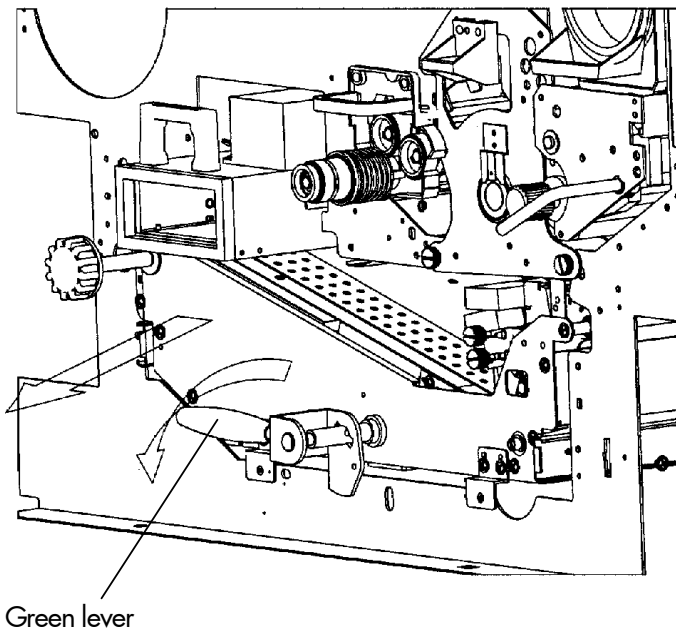

- Using an anti-static service vacuum cleaner, clean up toner, paper dust or other particles which may have accumulated.

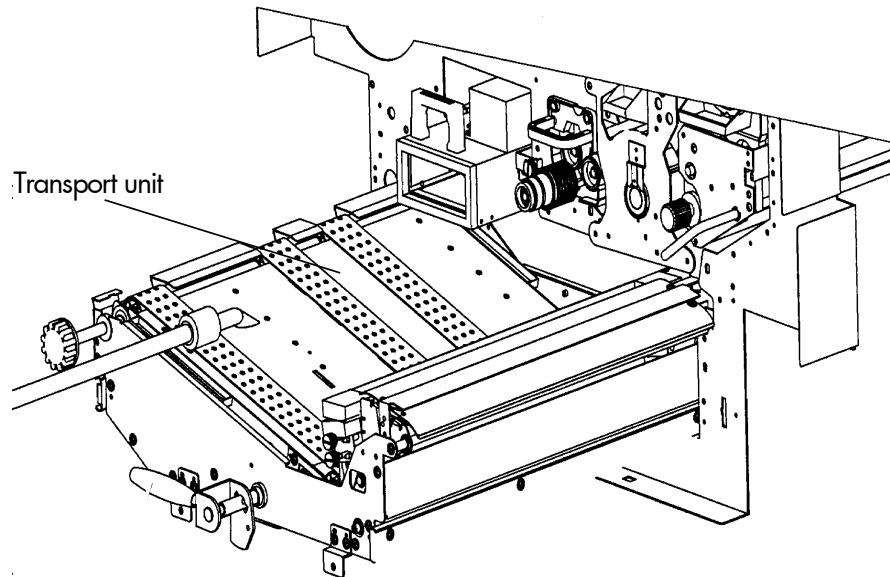

- Wipe off the dirt on the transport surface using a wet paper towel.

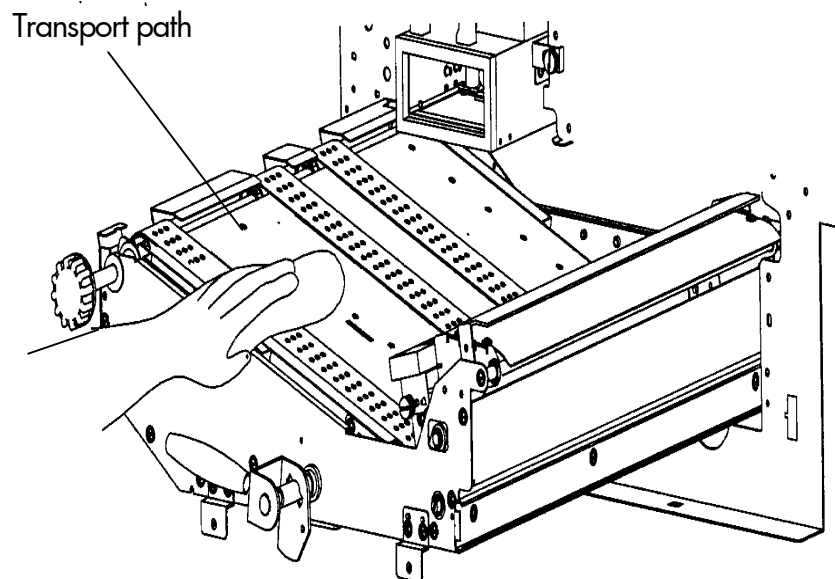

8. Replace the transport unit. The green lever has to be pressed down for this process. Slide the transport unit into the printer until it stops while pressing down the lever (resilience at the end). Tip up the green lever of the transport unit to its "up" position.



Pay attention to the second bar of the transport unit located under the green lever - it also has to click into place (second bar up).

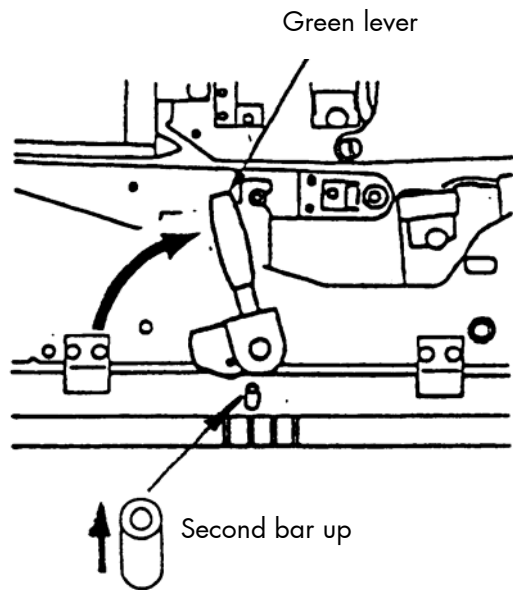

Green lever and second bar up have to be clicked into place to avoid damaging the printer.

9. Close the waste toner recovery unit.



Make sure the bars have engaged.

10. Close the printer's front cover.

6.3. Cleaning the Paper Feed Unit

1. Turn off the SOLID 85E printer and pull the power plug.
2. Remove the paper.
3. Absorb paper dust, sprayed toner etc. from the tractor and the area around it using an anti-static service vacuum cleaner.

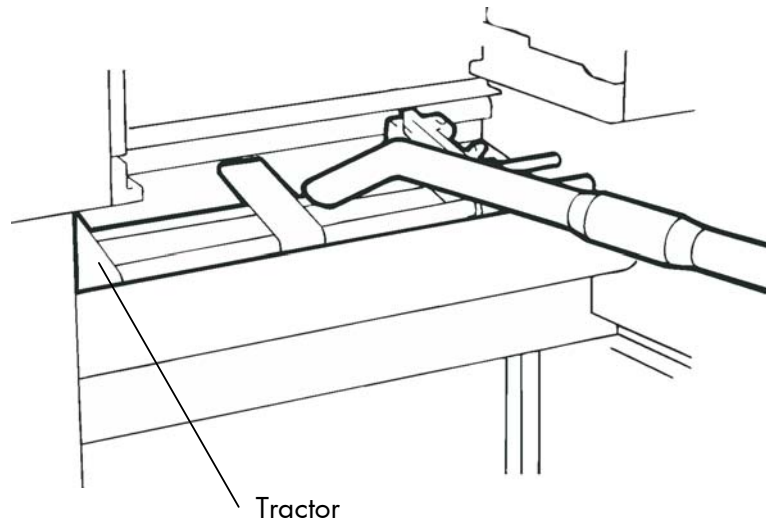

4. Load the paper.

6.4. Cleaning the Paper Near End Sensor



After 300,000 pages A4 have been printed, the Paper Near End Sensor (PNES) and the area around it should be cleaned carefully.

1. Turn off the SOLID 85E printer and pull the power plug.
2. Clean the PNES and the area around using a wet paper towel.

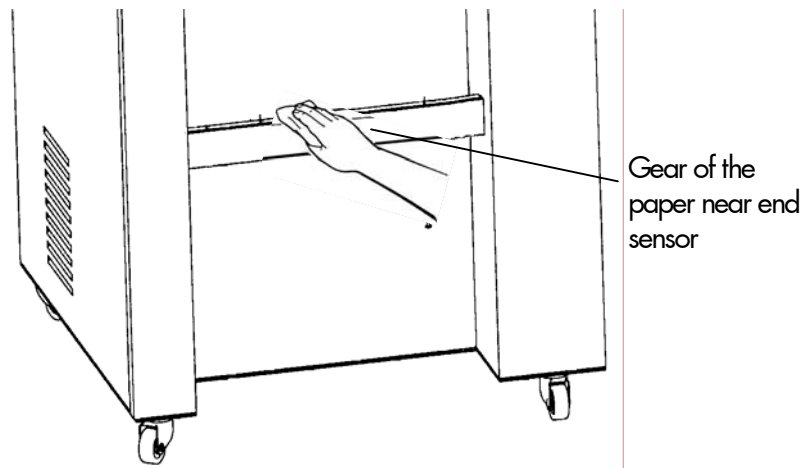

6.5. Cleaning the Power Stacker



After 200,000 pages A4 have been printed, the power stacker and the area around it should be cleaned using a vacuum cleaner.

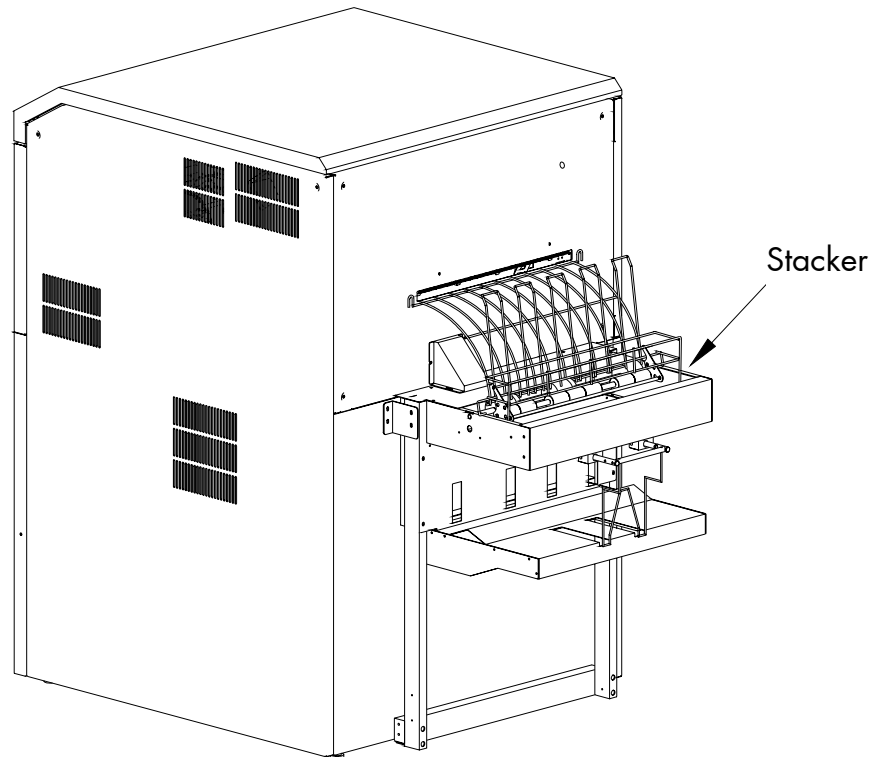

7. Operator Maintenance

In order to run the printer always on its highest quality level, it is necessary to perform regularly cleaning operations. In addition special components have to be replaced if the occasion arises. These operations can be performed by a MICROPLEX trained operator. A untrained person is not allowed to perform these operations.



The maintenance cycles given in this chapter are valid for printing with a print density of 5 % (if no other values are specified; see also chapter 10 Specifications).

Please note: The printer is provided with a drum counter.

The drum counter's meter readings can be used to calculate values for the "number of pages" (compare chapter 6 Printer cleaning; If, for example 20,000 pages A4 portrait Two-Up have been printed the number shown by the counter is approx. 7,900).



Further maintenance operations have to be done by the service engineer (in accordance with the hints given in the Service Manual).

7.1. Charger Cleaning



The operations described in this section have to be performed after the printing of every 50,000 pages A4 (portrait Two-Up).



Turn off the printer and pull the power plug before start working at the chargers.



To clean the chargers the following tools are available: a blower brush, a special wire cleaning tool and a emery block for the cleaning of the main charger's grid.



Please clean the chargers especially careful to avoid loosening or tearing the tightened wires. Improper replacement of the chargers into the printer may damage the photoreceptor drum.

7.1.1. Main Charger Cleaning



Turn off the printer and pull the power plug before start working at the chargers.

1. Open the front cover of the printer.

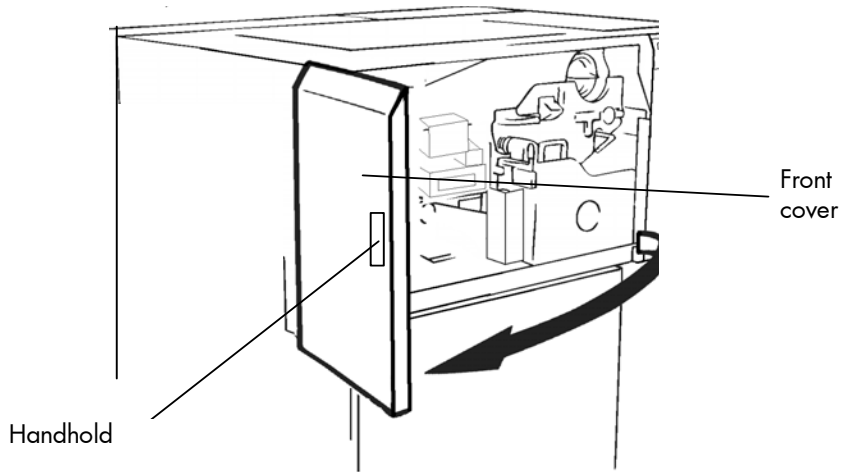

2. Pull out the cleaning rod horizontally and then insert it back several times for cleaning the wire of the main charger.

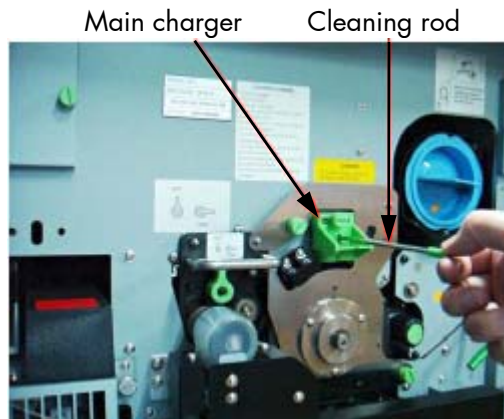

3. Loosen the knurled screw of the main charger and pull out the charger.

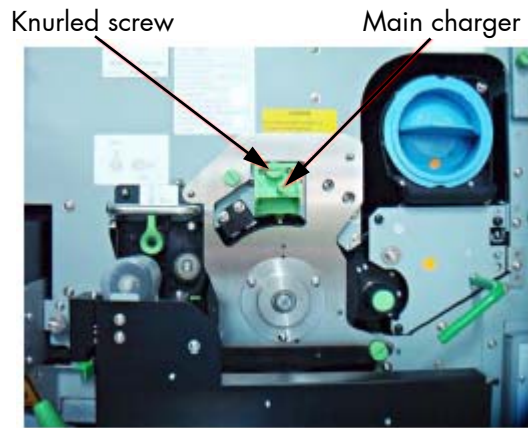

4. Place the charger on a clean and level worktop.
5. Clean the housing of the main charger using the blower brush.



6. Remove the grid from the main charger. For this please push on the tab and remove the grid.

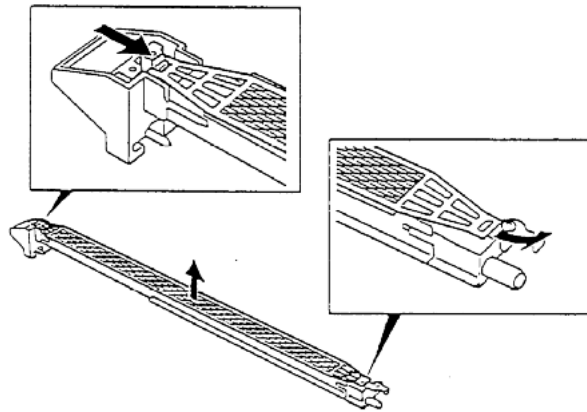

7. Use the wire cleaning tool to clean the charger's wire.
After this process the wire should be completely smooth.

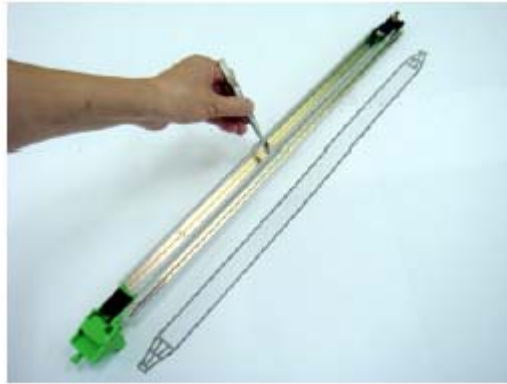

8. Reassemble the grid to the main charger. First you have to mount the grid to the plastic pin.

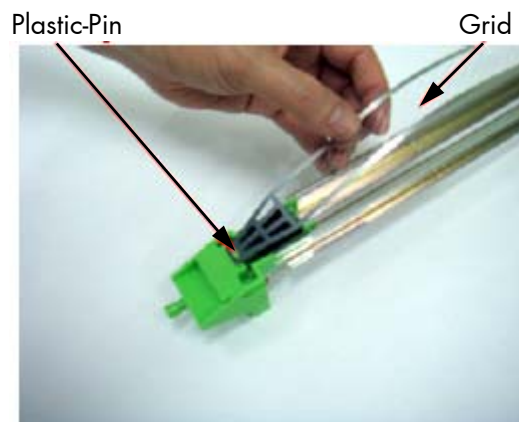

9. Hold the plastic end of the main charger while mounting the free end of the grid to the metal pin.

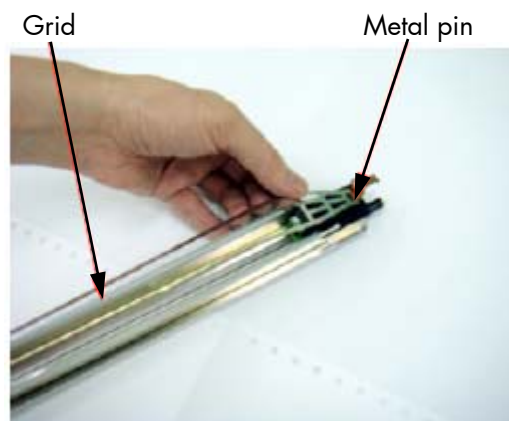

10. Replace the main charger in its original position (compare picture in step 2) and tighten the knurled screw.
11. Close the printer's front cover.

7.1.2. Pre-Charger Cleaning



Turn off the printer and pull the power plug before start working at the chargers.

1. Open the front cover of the printer.
2. Press down the open lever to open the waste toner recovery unit.

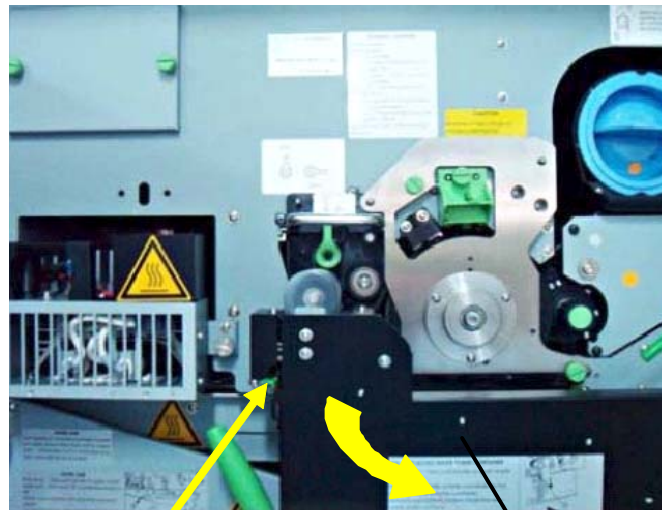

Open lever (green)

Waste toner recovery unit

3. Loosen the knurled screw of the pre-charger and pull out the charger.



Pre-charger

Knurled screw

4. Place the charger onto a clean and level worktop.
5. Using the blower brush, remove paper dust and other unwanted particles.
6. Clean the wire using the wire cleaning tool. After having finished this procedure the wire should be completely smooth.
7. Replace the charger in its original position and fasten the knurled screw to secure the charger.
8. Close the waste toner unit.



Make sure the bar has engaged.

9. Close the printer's front cover.

7.1.3. Transfer-/Separator Charger Cleaning



Turn off the printer and pull the power plug before start working at the chargers.

1. Open the front cover of the printer.
2. Press down the open lever to open the waste toner recovery unit.

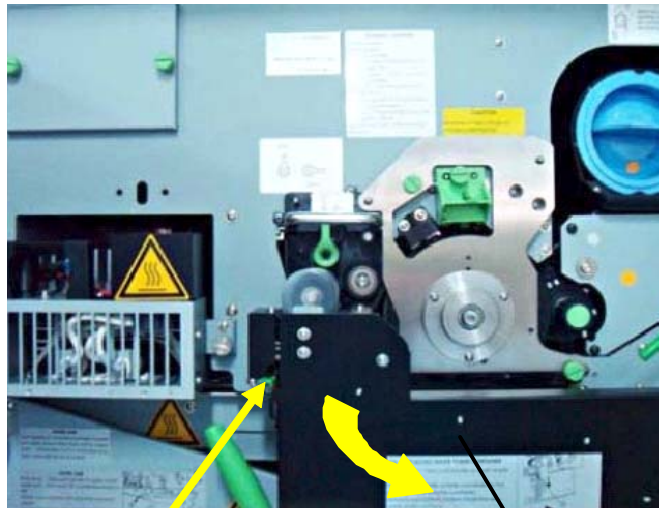

Open lever (green)

Waste toner recovery unit

3. Pull out the cleaning rod horizontally and then insert it back several times for cleaning the wire of this charger.



Transfer-/Separator charger

Cleaning rod



Before performing the next step make sure the transfer-/separator charger is in its "down" position to avoid damaging the photoreceptor drum.

Please go on like this:

- Take a slotted screwdriver and turn the transfer elevator drive shaft (see following figure) clockwise, for example. While doing this, watch the movement of the transfer charger.
- If the charger has moved upwards, please turn the drive shaft backwards now until the charger is in the down position.
- If the charger has moved downwards, continue in turning the drive shaft until the charger is in the deepest position.

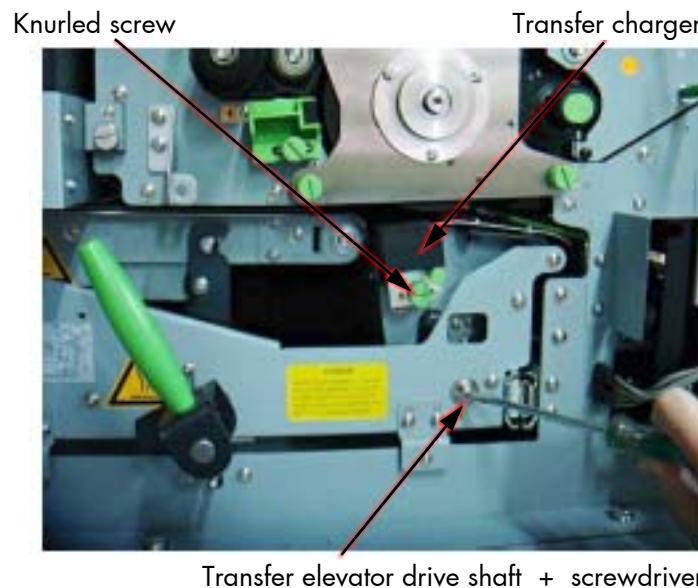

4. Turn to loosen the knurled screw at the transfer-/separator charger and pull the charger out.
5. Place the charger onto a clean and level worktop.
6. Using the blower brush, remove paper dust and other unwanted particles.
7. Then clean the wire using a wire cleaning tool. After having finished this procedure the wire should be completely smooth.

8. Replace the charger in its original position and tighten the knurled screw.

9. Close the waste toner recovery unit.



Make sure the bar has engaged.

10. Close the front cover of the printer.

7.2. Developer Unit Cleaning



Please check the extend of soiling of the developer unit every time the toner cartridge is replaced (see section 3.2).
Cleaning the developer unit has to be done in due time to avoid reduced print quality (see section 8.1, too).



Please clean the developer unit especially careful to avoid damaging the sensors.

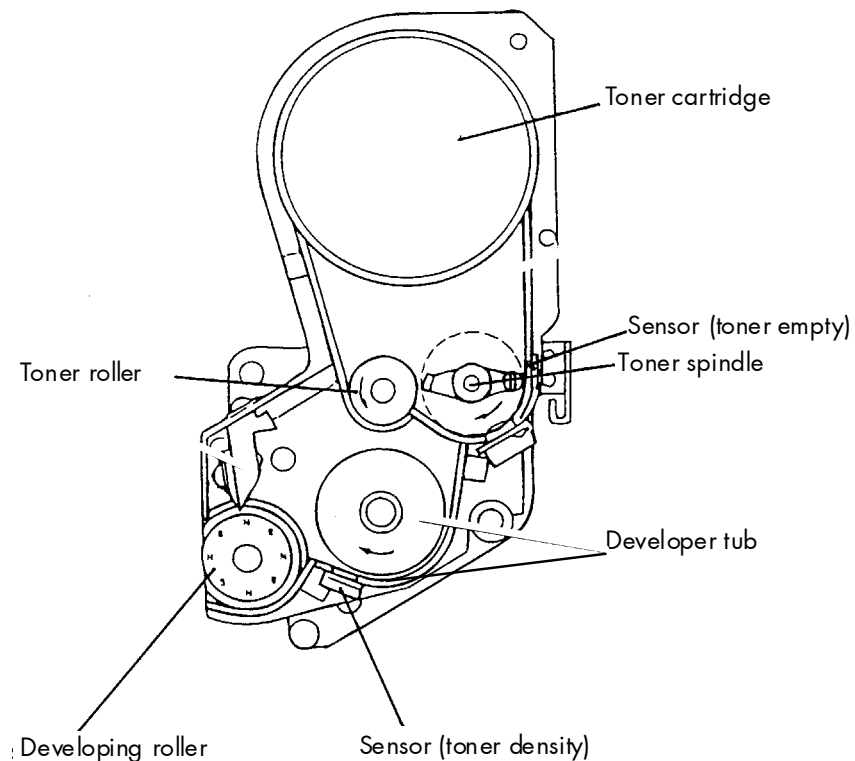
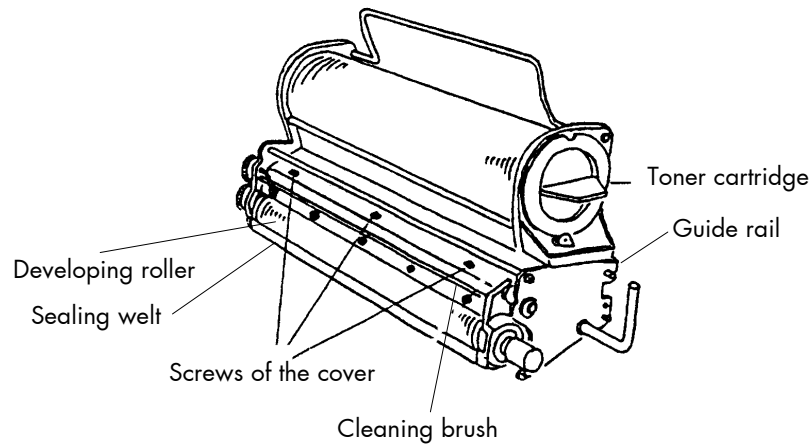

1. Turn off the printer and pull the power plug.
2. Open the front cover of the printer.

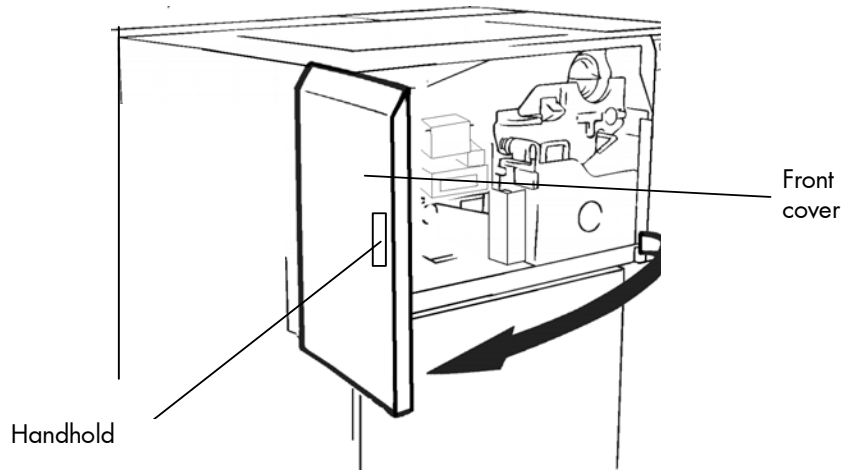

3. Turn the lever of the developer unit clockwise until it points up. The developer unit will be separated from the photo-receptor drum by this operation.

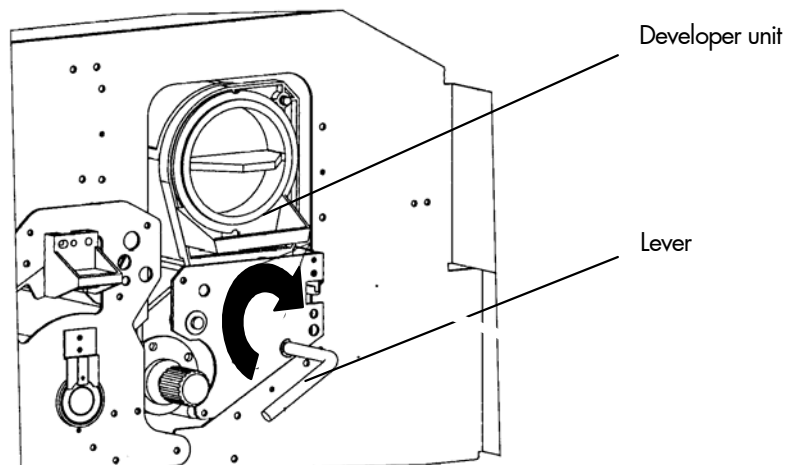

Pay attention to a correct performance of this operation to avoid damaging the photoreceptor drum in the following steps.

4. Push the developing unit lock (see following figure) to the right and hold the lock in this position. Then pull out the developing unit partially using the lever.

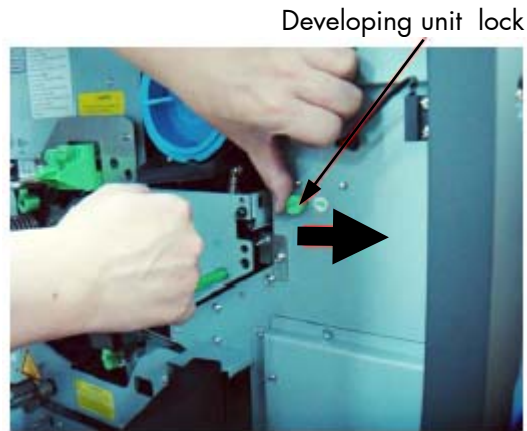

5. Now reach for the handle with your left hand (see following figure) and pull out the developing unit a little more.

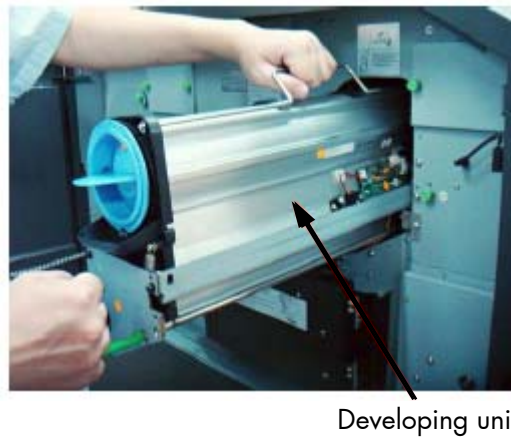

6. Push the developing unit lock to the right now (see following figure) and hold the lock in this position. Then completely remove the unit from the printer and place it on a covered, level worktop.



Developing unit lock

7. For developer unit cleaning make a potential compensation (grounding) with the printer cabinet. At the developer unit the grounding has to be connected to the back screw of the cover (see picture below).

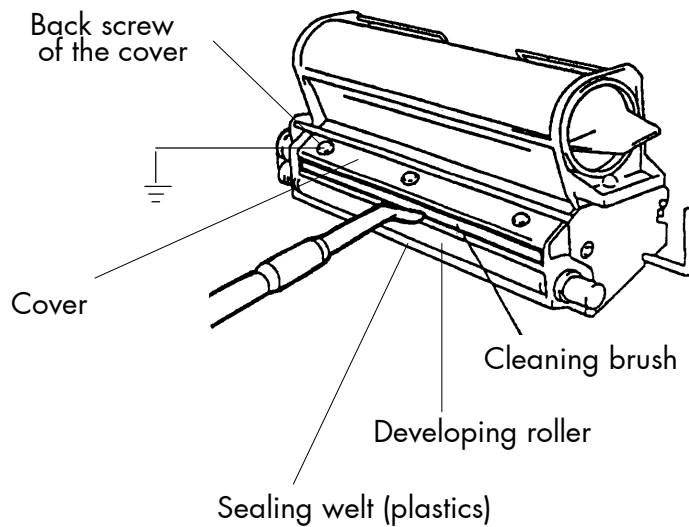

8. Clean carefully the cleaning brush and the sealing welt with an anti-static service vacuum cleaner and remove also the toner from the cover of the developer unit.

9. Remove the potential compensation.
10. Reinstall the developer unit (see the following section).
11. Close the printer's front cover.

7.3. Developer Unit Refurbish, Developer Powder Exchange

After having printed approximately 424,000 pages A4 (portrait Two-Up) the developer powder should be exchanged.
If possible combine with an exchange of the toner cartridge.

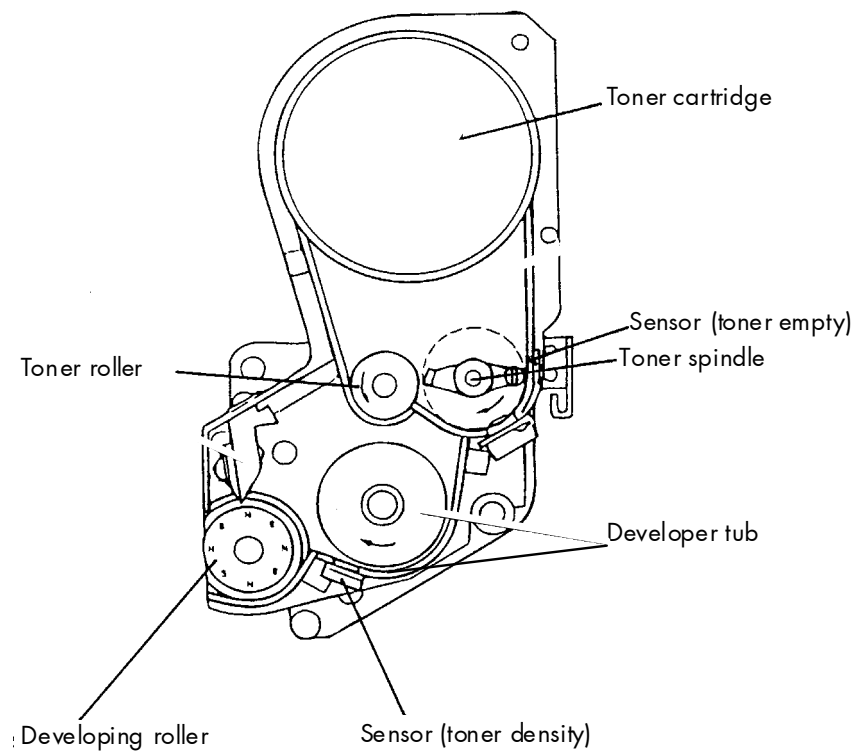

1. Turn off the printer and pull the power plug.
2. Open the front cover of the printer.

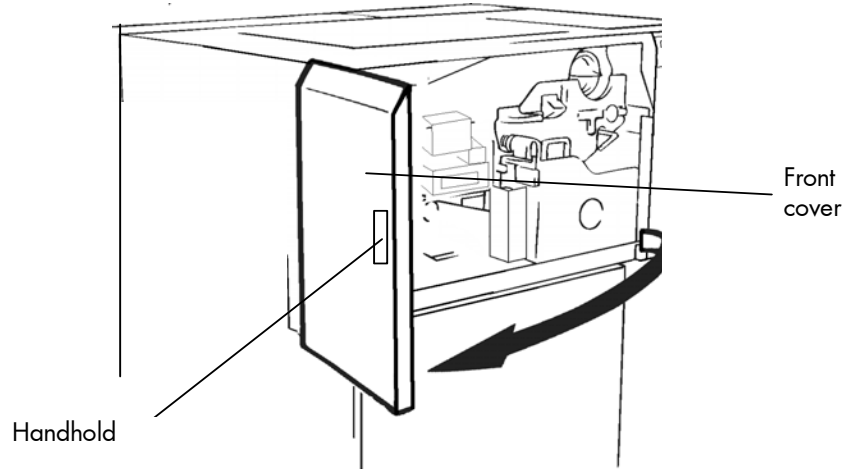

3. Remove the developer unit from the printer (see previous section) and place the unit on a covered level worktop.



Please wear vinyl-gloves to avoid dirty hands.



Please be especially careful when carrying out the following operations to avoid damaging the sensors. The toner sensors may be damaged by electrostatic discharge or changing of the position. Do not touch or move the sensors.

4. Turn to loosen the four screws (B) at the upper inside cover (C) of the developing unit and remove the cover (see the following figure). Reinstall the back fastening screw (B).

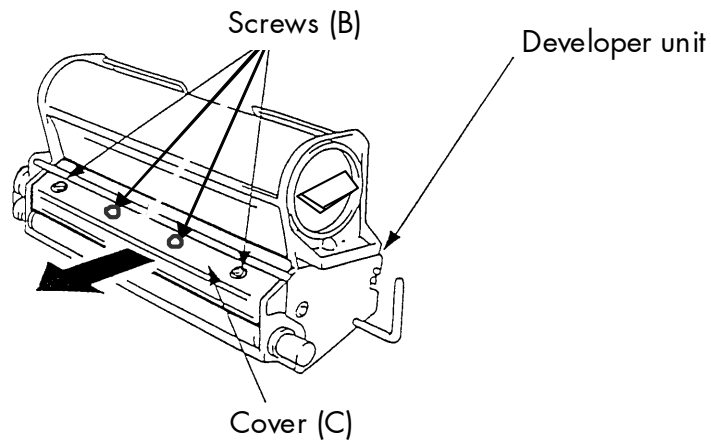

5. Please make a potential compensation (grounding) between the developer unit and the printer cabinet before you exchange the developer powder (vacuum). The grounding has to be connected to the back fastening screw (B) of the cover.

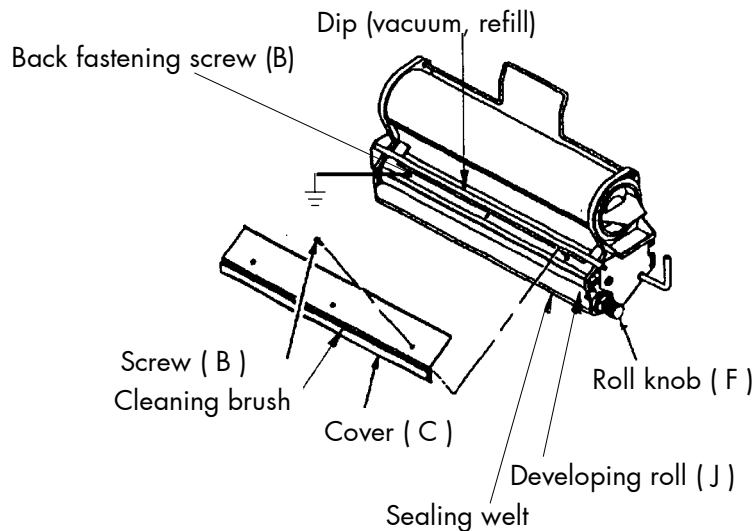

6. Remove the developer - toner mixture completely out of the developer tub (see figure at the beginning of this section) using an anti-static service vacuum cleaner. Clean also the developer roll while turning it counterclockwise (roll knob F).

7. After that please clean the cover of the developer unit, the cleaning brush and the sealing welt.
8. Shake the developer bottle several times, open the cap (D) and tighten the nozzle (E).

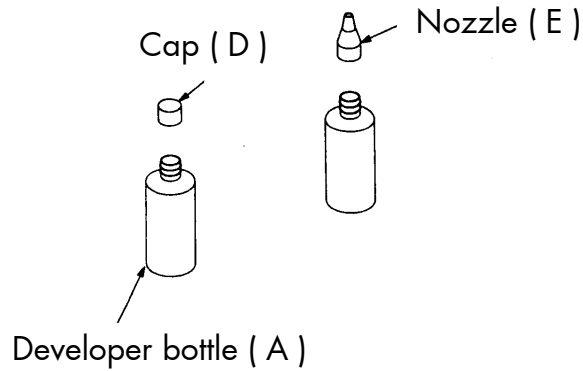

9. Fill the developer powder completely into the unit and turn the roll knob (F) counterclockwise during the filling operation.

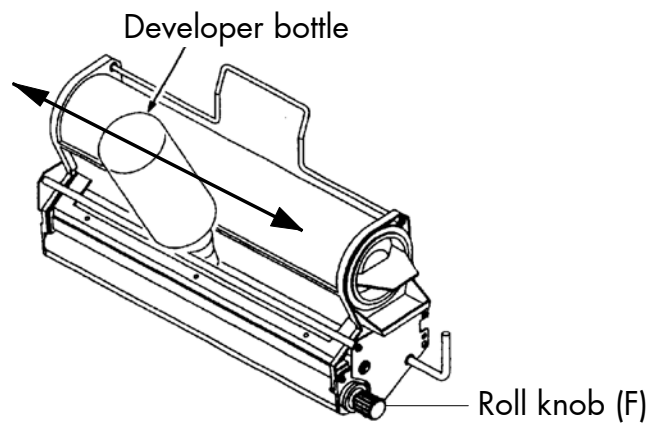

10. Remove the potential compensation and fix the cover (C) and the screws (B) again.



Before reinstalling the developer unit make sure the lever of the unit points up to avoid damaging the photoreceptor drum.

11. Hold the lever with one hand and the handle with the other one and place the developer unit onto the guide rail.

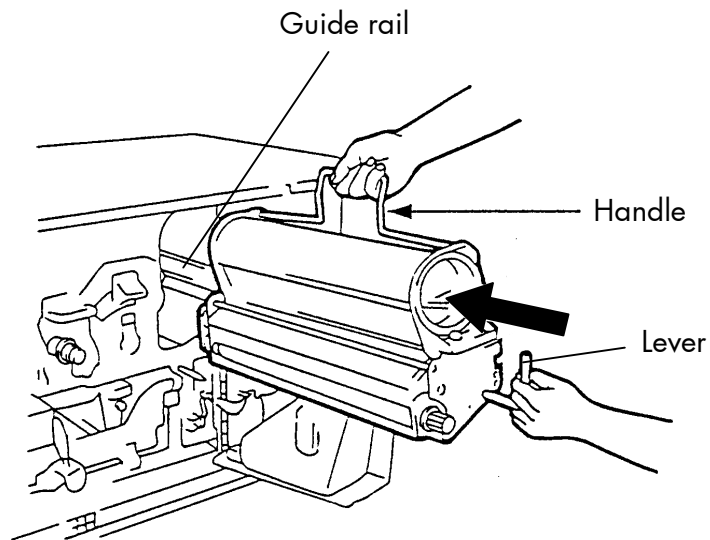

12. Turn the handle to the right so it rests against the developer unit and slide the unit back into the printer.

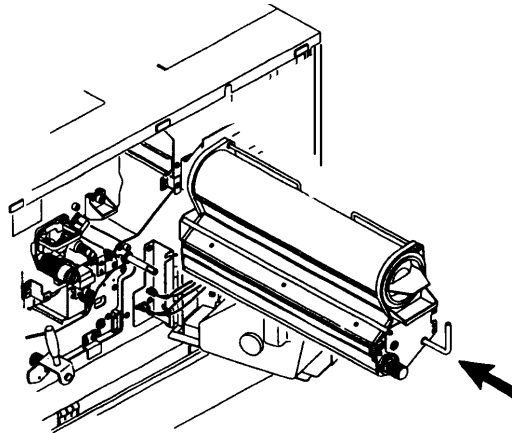

13. Turn the roll knob (F) step by step counterclockwise until you can slide the unit into its original position. The guiding cone of the alignment pin has to project through the developer unit frame completely in the original position.

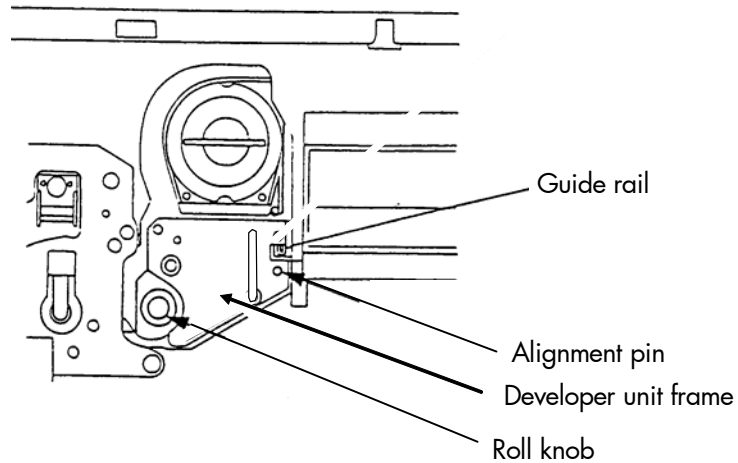

14. Turn the lever of the developer unit counterclockwise until it stops to fix the position.

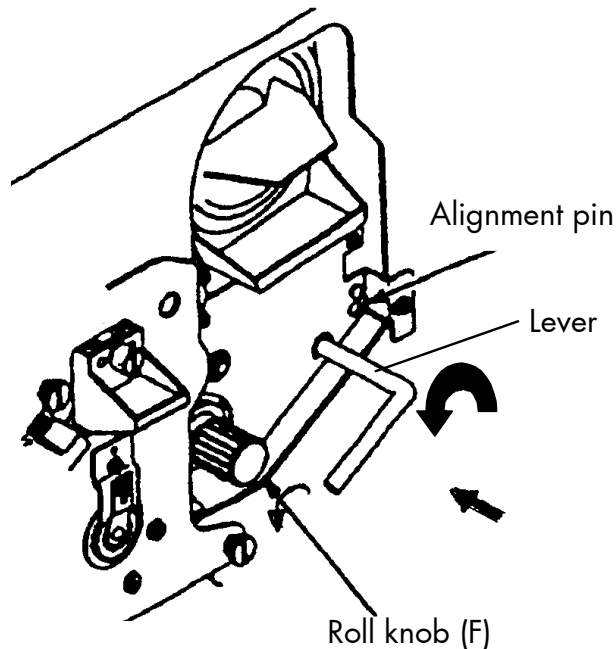

15. Close the waste toner recovery unit (if need be) by clicking it into place.
16. Close the printer's front cover.
17. Turn on the printer.
18. Generate a few test printouts.

7.4. Main Charger Replacing

After having printed 424,000 pages A4 (portrait Two-Up) the main charger has to be replaced.



Turn off the printer and pull the power plug before start working at the chargers.

1. Open the front cover of the printer.
2. Turn the knurled screw of the main charger to loosen it and pull the main charger out towards you.

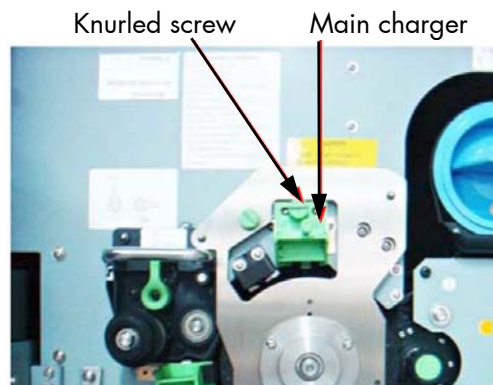

3. Replace the new main charger in its original position and fasten up the knurled screw to secure the charger.
4. Close the printer's front cover.

7.5. Pre-Charger Replacing

After having printed 636,000 pages A4 (portrait Two-Up) the pre-charger has to be replaced.



Turn off the printer and pull the power plug before start working at the chargers.

1. Open the front cover of the printer.
2. Open the waste toner recovery unit.

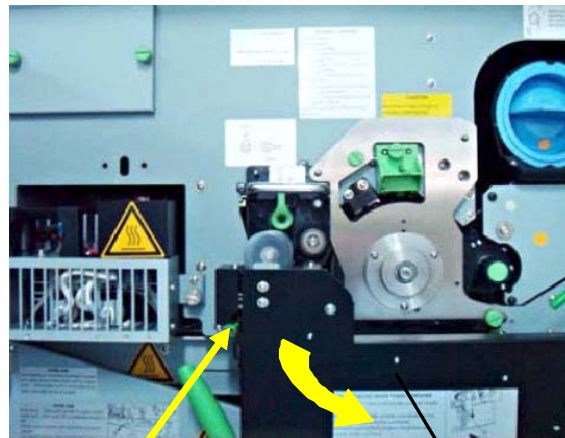

Open lever (green)

Waste toner recovery unit

3. Turn to loosen the green knurled screw of the pre-charger and pull the pre-charger out towards you.

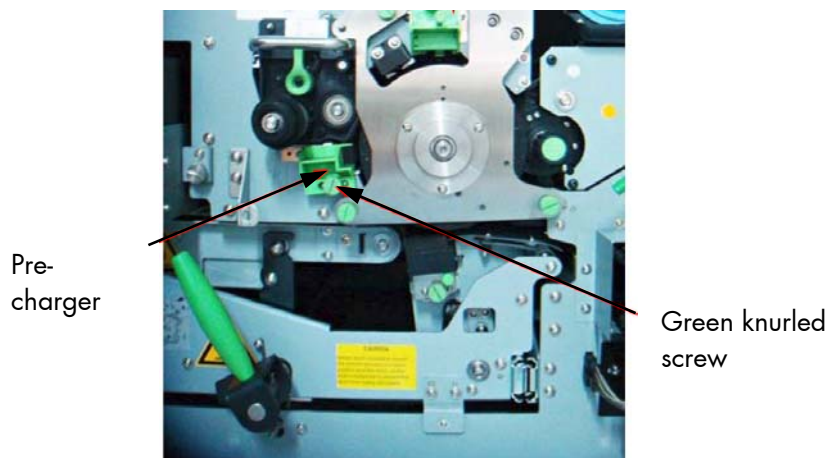

Pre-charger

Green knurled screw

4. Install the new charger in its original position and tighten the screw.

5. Close the waste toner recovery unit.



Make sure the bar has engaged.

6. Close the printer's front cover.

7.6. Transfer-/Separator Charger Replacing

After having printed 636,000 pages A4 (portrait Two-Up) the transfer-/separator charger has to be replaced.



Turn off the printer and pull the power plug before start working at the chargers.

1. Open the front cover of the printer.
2. Open the waste toner recovery unit.

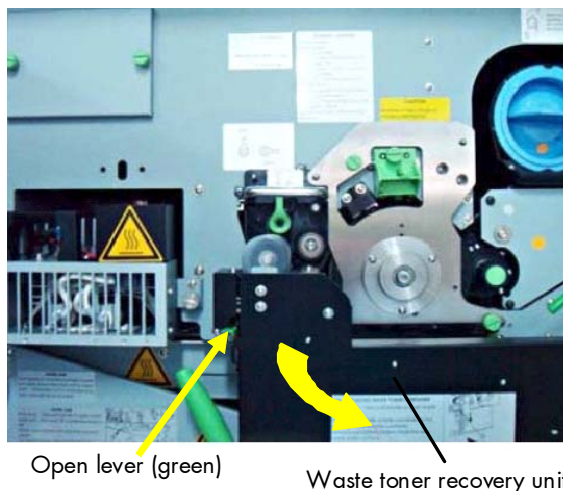

Before performing the next step make sure the transfer-/separator charger is in its "down" position to avoid damaging the photoreceptor drum.

Please go on like this:

- Take a slotted screwdriver and turn the transfer elevator drive shaft (see following figure) clockwise, for example. While doing this, watch the movement of the transfer charger.
- If the charger has moved upwards, please turn the drive shaft backwards now until the charger is in the down position.
- If the charger has moved downwards, continue in turning the drive shaft until the charger is in the deepest position.

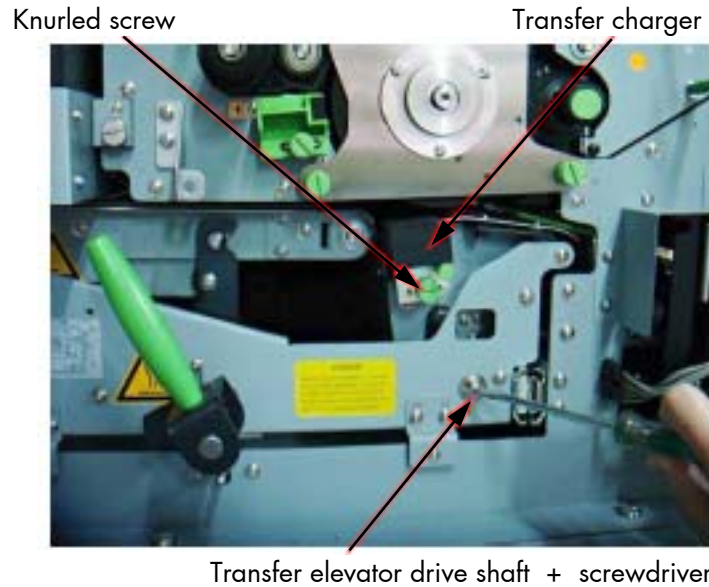

3. Turn to loosen the knurled screw of the transfer-/separator charger and pull the transfer-/separator charger out towards you.
4. Replace the new transfer-/separator charger in its original position and fasten up the knurled screw to secure the charger.
5. Close the waste toner recovery unit.



Make sure the bar has engaged.

6. Close the printer's front cover.

7.7. Photoreceptor Drum Exchange



After having printed a maximum of 424,000 pages A4 (portrait Two-Up) the photoreceptor drum has to be exchanged.



1. Turn off the printer and pull the power plug before start working.
2. Open the front cover of the printer.

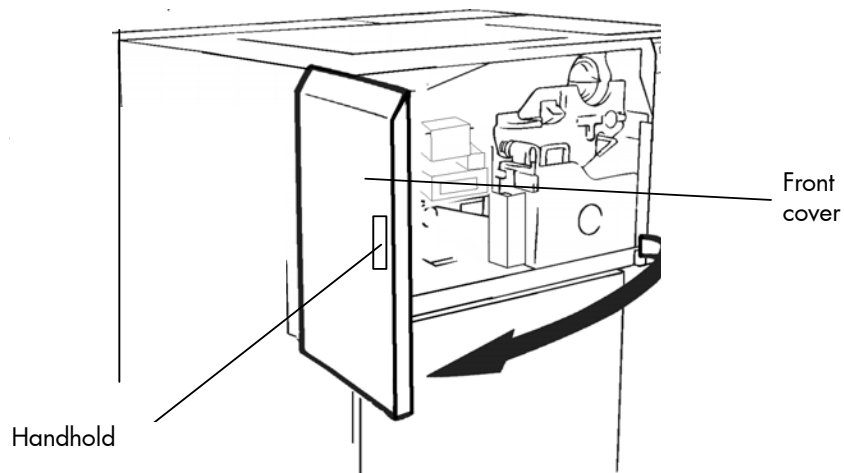

3. Turn the lever of the developer unit clockwise until it points up. The developer unit will be separated from the photoreceptor drum by this operation.



Lever



Pay attention to a correct performance of this operation to avoid damaging the photoreceptor drum in the following steps.

4. Open the waste toner recovery unit.

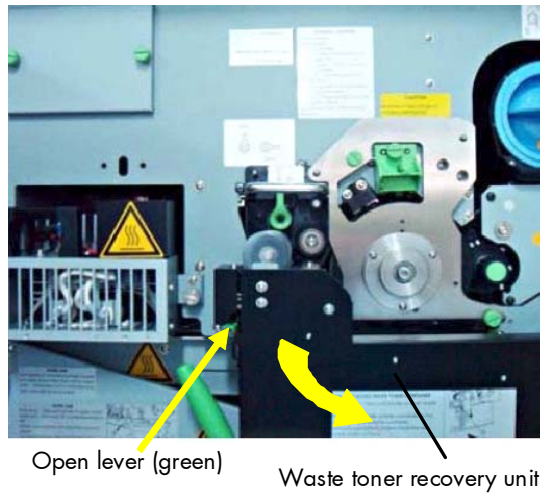

Before performing the next step make sure the transfer-/separator charger is in its "down" position to avoid damaging the photoreceptor drum.

Please go on like this:

- Take a slotted screwdriver and turn the transfer elevator drive shaft (see following figure) clockwise, for example. While doing this, watch the movement of the transfer charger.
- If the charger has moved upwards, please turn the drive shaft backwards now until the charger is in the down position.
- If the charger has moved downwards, continue in turning the drive shaft until the charger is in the deepest position.

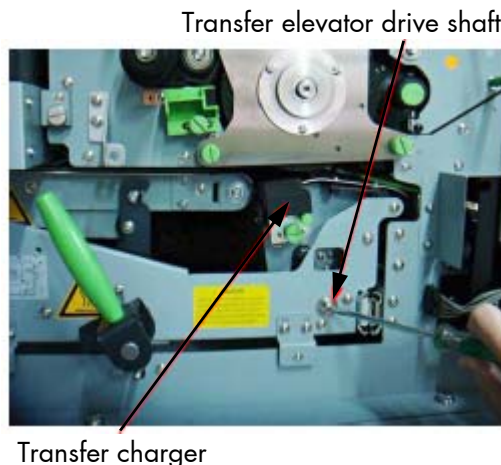

5. Turn the green lock lever of the cleaning unit to the "open" position (the lever has to point to 3 o'clock).

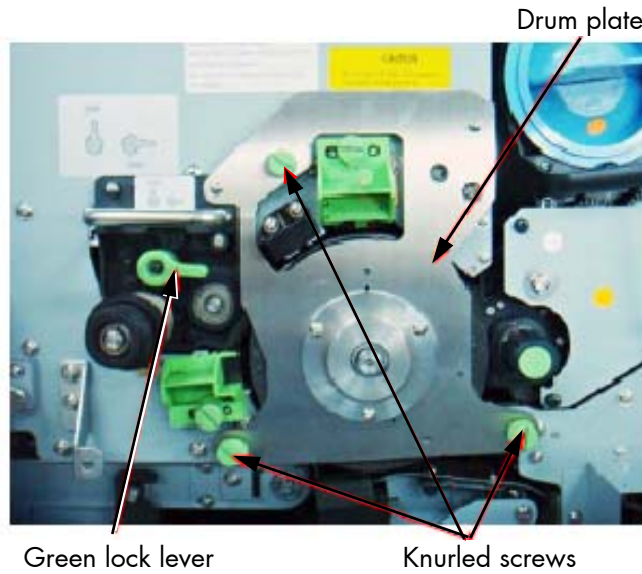

6. Turn to loosen the three knurled screws the drum plate is fixed with (see figure above) and remove the drum plate.

7. Remove the nut from the drum shaft.



During this operation the drum must not rotate!

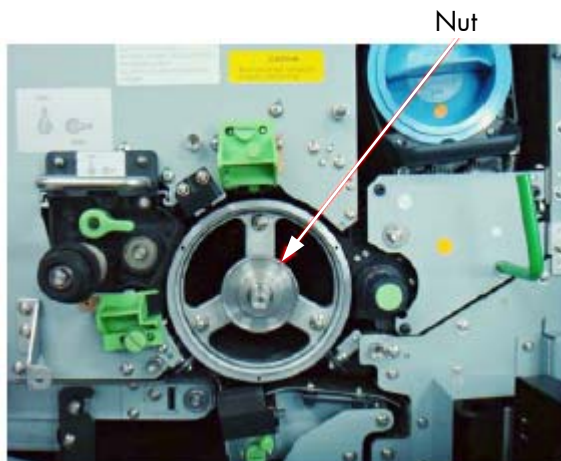

8. Fix the auxiliary rod at the drum shaft.

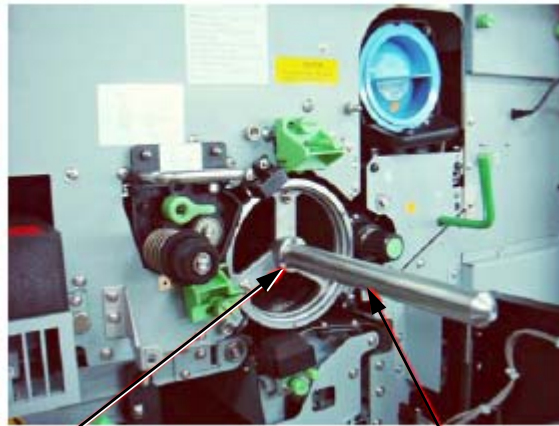

Drum shaft

Auxiliary rod



Do not touch the drum surface because the material is easy to damage.

9. Pull out the old drum carefully along the auxiliary rod.
Hold the drum at its front and rear side and remove it out of the device using both hands.



Drum

10. Check the O-rings attached on the drum support rollers and replace them with new O-rings, if need be. (See next figure.)

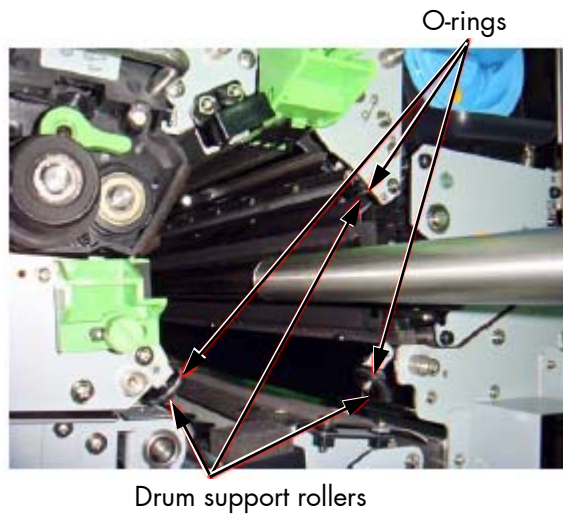

11. Keep the old drum in its original packing until disposal.
12. Clean the drum shaft with a lintfree cloth.
13. Put the new photoreceptor drum out of its packing and clean the end caps of the drum with a lintfree cloth.



Please keep the packing materials for the future disposal of the new drum.



Please avoid exposing the drum to the daylight longer than 5 minutes and don't touch the drum surface.

14. Put the drum carefully with both hands onto the auxiliary rod. When the drum is reaching the position, where the auxiliary rod is fixed at the drum shaft, lift the drum carefully (not by force) over the connection.



Please secure that the drum lies on the Drum support rollers (see figure above) to avoid damage when you move it into the device.



If the position of the drum is not correct, take it out again and look for foreign particles or other stoppages at the shaft.

15. Turn the photoreceptor drum by hand and press it a little bit into the device until it stops at the rear. After that turn the drum clockwise until it engages.



Please be especially careful when carrying out this operation to avoid damaging the printer.

16. Remove the auxiliary rod from the drum shaft.
17. Put the nut to the drum shaft and fix it well.
18. Install the drum plate and tighten the knurled screws. Please pay attention, that the ball-bearing doesn't cant.



19. After the drum installation please measure the resistance. For that you put the positive circuit of a digital multimeter to the drum edge and the negative circuit to a grounded part of the printer (for example a screwhead belonging to the printer chassis). The normal resistance should be 0 Ω .

20. Turn the lever of the developer unit counterclockwise until it points to the lower left (see following figure).
By this operation the developer unit is no longer separated from the photoreceptor drum.

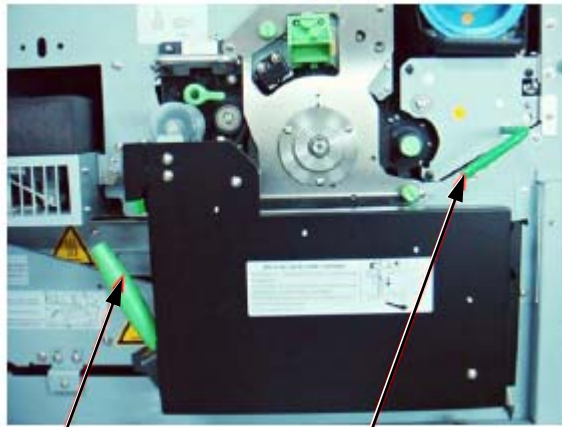

Green lever Lever of the developer unit (here already turned)

21. Take care that the Green lever of the transport unit is in its "up" Position (see figure above).



22. Close the waste toner recovery unit. Make sure the bar has engaged.

23. Close the printer's front cover.

24. Make sure paper is set correctly (see section 3.1, too).

25. Turn the printer on.

During the following warm up time the printer's panel display shows the message "WARM UP".

After a certain time the message [Clean.U.SetIncor.!]
[E0024]

is displayed.

26. Now please open the printer's front cover.

27. Turn the green lock lever of the cleaning unit to the "lock" position (the lever has to point to 12 o'clock; see next figure).



Green lock lever

28. Close the printer's front cover.
29. Press the "ON LINE" key on the printer's control panel to clear the error message.

Now the process of OPC drum initialization is working for a while. After that the printer will switch to the "READY" status.



Disposal of the old OPC drum will be carried out by your service engineer. Until disposal please keep the photoreceptor drum in its original packing.

8. Troubleshooting



When an error occurs, a corresponding error message is displayed in the control panel (see section 8.2).

Please address the problems described in section 8.1 and 8.2 yourself, especially the consumable replacement.



Only a MICROPLEX authorized operator or service engineer should address printer problems for which no detailed remedies are given in the following pages.

When reporting a problem to your service engineer, please give him the exact error message. That helps to localize the error more quickly.

If an error message indicates a paper jam, a print repetition will be necessary.



The printer is provided with an automatic jam safety routine to prevent a loss of information.

This automatically jam safety routine can also be switched off, if the user wants to take up the print job at a passage chosen by himself (see section 5.6 Clearing the Input Buffer).

8.1. Reduced Print Quality

The troubles listed below can often be solved by the corresponding hints.
Please inform your service engineer if the troubles occur again after the correction.

<u>Trouble</u>	<u>Correction</u>
The printout is partially uneven.	Clean the wires of the transfer-/separator charger (see section 7.1.3).
The printout performance decreases slowly.	Replace the transfer-/separator charger (see section 7.6).
The printout has "empty" spots.	Use only dry fanfold paper.
The printout shows partially grey stripes.	Clean the wires of the main charger (see section 7.1.1).
The printout shows a grey background.	Clean the wires of the pre-charger (see section 7.1.2).
There are spots of toner on the printout.	<p>The Pre-charger is dirty:</p> <ul style="list-style-type: none"> - Clean the pre-charger (see section 7.1.2). <p>Developer unit dirty:</p> <ul style="list-style-type: none"> - Clean the developer unit (see section 7.2). <p>Replace the toner cartridge (see section 3.2)</p>

<u>Hint:</u>	Fanfold material cannot be printed in the area of the sprocket holes, even in the distance up to 5mm around the sprocket holes a reduced print quality has to be expected.
--------------	--

8.2. Error Messages

In the following the individual error messages that may appear on the display are shown in the following systematic manner:

[Error message]	Short description
[Error code]	Remedy
[Cover Open!]	The front cover has not been closed completely.
[E0001]	Please close it completely.
[No Paper!]	The printer has no paper.
[E0002]	Please load paper. Check whether paper is set correctly or not (see section 3.1).
[Jam at Fuser!]	Paper jam in the fusing section.
[E0003]	Remove the jammed paper (see section 8.3).
[Jam after Fuser!]	Paper jam behind the fusing section.
[E0004]	Remove the jammed paper (see section 8.3).
[Jam at Output!]	Paper jam in the exit unit.
[E0005]	Remove the jammed paper (see sections 8.3).
[NoPap.at Tractor!]	There is no more fanfold paper on the tractor.
[E0006]	Check whether paper is set correctly or not (compare section 3.1).
[Scuff Lev. open!]	Knob "B" (scuff roller) is free.
[E0007]	Turn knob "B" counterclockwise to lock (see section 8.3.2).
[Transp.PathOpen!]	The paper path is open.
[E0008]	Use the green lever to close the paper path (compare section 8.3.2).
[Paper at Output!]	There is still paper within the output section.
[E000E]	Remove the paper (see section 8.3).
[Tract.Guide Open!]	Check the tractor unit.
[E000F]	Close the tractor guides.

<u>Error code</u>	<u>Description</u>
[Pap.at Sep.Sec.! [E0011]] There is still paper within the separator unit. Remove the paper (see section 8.3).
[Paper at Fuser! [E0012]] There is still paper within the fuser unit. Remove the paper (see section 8.3).
[Paper at Output! [E0013]] There is still paper within the exit unit. Remove the paper (see section 8.3).
[Abnorm.PaperPos.! [E0016]] Paper jam within the feeding unit. Remove the jammed paper (see section 8.3) and press the key SPLIT.
[No Clean. Unit! [E0026]] The cleaning unit is missing. Install the cleaning unit.
[WasteTon.BoxFull! [E0028]] The waste toner bottle is full. Replace the bottle with a new one (see section 3.3).
[No Waste Ton.Box!] [E0029]] There is no waste toner bottle within the unit. Insert a waste toner bottle (see section 3.3).
[No Toner! [E002A]] There is no more toner within the cartridge. Insert a new toner cartridge (see section 3.2).
[Toner Low [E002D]] The message [Toner Low] is only a warning that the printer will run out of toner soon. Replace the toner cartridge as soon as the message [No Toner] is displayed (see section 3.2).
[Rear Cover Open! [E0033]] The rear cover has not been closed completely. Please close it completely.

<u>Error code</u>	<u>Description</u>
-------------------	--------------------

Hint:

[E005 at the beginning of the error code indicates **stacker error messages:**

[Stacking Fail! [E0055]]	Fanfold paper is not folded correctly. Check whether paper is set correctly or not.
[Stacker Full! [E0056]]	The power stacker is full. Please remove the paper.
[Stacker Not Rdy! [E0057]]	Stacker is not ready
[Stack.Limit Err.! [E0059]]	Stacker capacity is exceeded. Please remove the paper.

More error messages are listed in section 8.2.1.



If the remedies above are not successful, please call a MICROPLEX authorized service engineer.

When reporting a problem to your service engineer, please give him the precise error message. That helps to localize the error more quickly.

8.2.1. Further Error Messages and Error Codes

The following printer errors will be displayed in the panel by a hex number and a shortened error messages (or the word "ERROR").

Only a MICROPLEX authorized operator or service engineer should address the printer problems listed in the following table.

(Exception: some errors, which are listed in the superior section 8.2, too.)

<u>Error code</u>	<u>Description</u>
[Cut Fail.Front! [E000A] Cut motor does not work normally (at the front)]
[Cut Fail. Rear! [E000B] Cut motor does not work normally (at the rear)]
[Elev.M.Err.Front! [E000C] Transport motor does not work normally (no up position)]
[Elev.M.Err.Rear! [E000D] Transport motor does not work normally (no down position)]
[Paper at Fuser! [E0012] Paper does not leave the fuser unit (compare section 8.2 and 8.3).]
[Paper at Output! [E0013] Paper does not leave the paper exit (comp. section 8.2 and 8.3)]
[Abnorm.PaperPos.!! [E0016] Position of fanfold paper is not normal]
[High Volt.Fail.!! [E0017] High voltage providing is not normal]
[Drum Motor Fail.!! [E0018] Drum motor does not work normally]
[Surf.Pot.tooHigh! [E0019] Surface potential is not normal (too high)]
[Surf.Pot.tooLow! [E001A] Surface potential is not normal (too low)]

<u>Error code</u>	<u>Description</u>
[No Pre Charger! [E001B] Pre charger is missing
[Flash Failure! [E001F] Flash is missing
[Fuser Overheat! [E0020] Fuser unit is too hot
[Dev.Motor Fail! [E0022] Developer motor does not work normally
[Dev.UnitSetIncor.! [E0023] Developer unit setting is not correct
[Clean.U.SetIncor.! [E0024] Cleaning unit setting is not correct
[No Clean. Unit! [E0026] Cleaning unit is missing
[WasteTon.BoxFull! [E0028] Waste toner bottle is full
[No Waste Ton.Box! [E0029] Waste toner bottle is missing
[No Toner! [E002A] No toner
[Toner Low [E002D] Toner density is not normal (too low)
[LED Array Overh.! [E0032] LED head is too hot

<u>Error code</u>	<u>Description</u>
[Stack.Com.Err.OR! E0050] Communication error at the power stacker (overrun error)
[Stack.Com.Err.PE! E0051] Communication error at the power stacker (parity error)
[Stack.Com.Err.FE! E0052] Communication error at the power stacker (framing error)
[Stack.Com.Err.CE! E0053] Communication error at the power stacker
[Stack. Interlock! E0054] Error at the locking device of the power stacker
[Stacking Fail.! E0055] Fanfold paper is not folded
[Stacker Full! E0056] Stacker is full
[Stacker Not Rdy! E0057] Stacker is not ready
[Stack.NoAutoMode! E0058] No auto mode
[Stack.Limit Err.! E0059] Stacker capacity is exceeded
[Stacker.Mot.Error! E005A] Motor rotation is not normal
[Stacker Busy! E005B] Power stacker is active
[Stack.LowestPos.! E005C] Error at the stacker
[Stack.Com.T.Out! E005D] Communication error (timeout)

8.3. Paper Jam

8.3.1. Paper Jam inside the Tractor

1. Open the paper retaining levers.

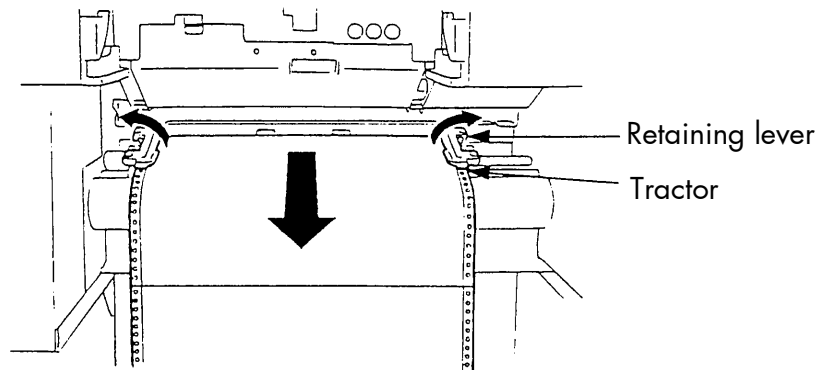

2. Remove the jammed paper. Detach the creased paper at the perforation.
3. Pull the paper out of the device only in the transport direction.
4. Insert the paper again (see section 3.1).



Please do not push the paper beyond the tractor into the device to avoid reaching the Paper Jam Sensor.

8.3.2. Paper Jam inside the Print System



The components of the fuser unit and the transport unit can get hot. Please wait until they have cooled down.

1. Open the front cover of the printer.
For this procedure the paper transport should be finished for at least 15 seconds.

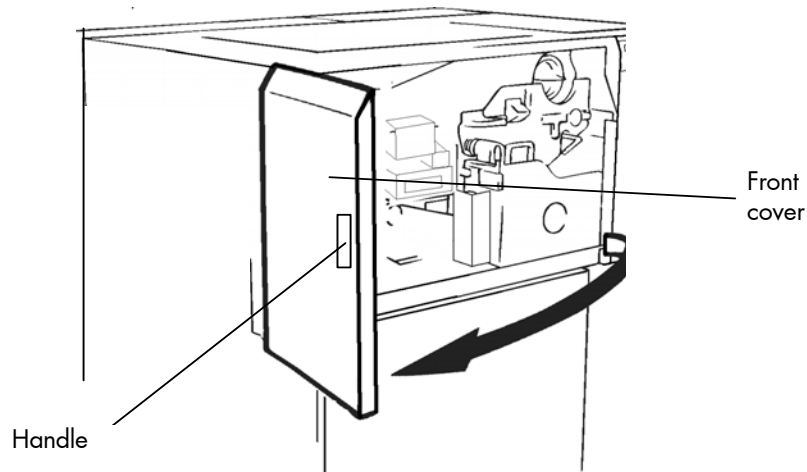

2. Press down the open lever of the waste toner recovery unit and open the unit.

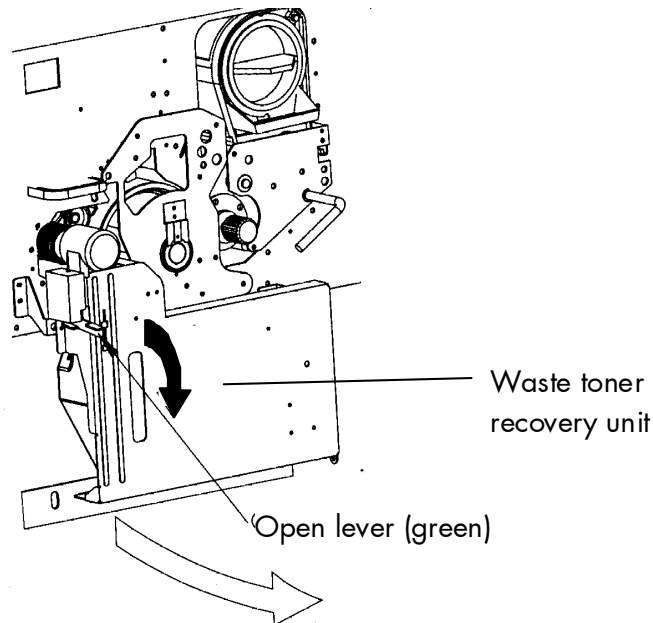

3. Turn the green lever at the transport unit counterclockwise downwards. The transport path will be shifted down. Do not pull out the transport unit.

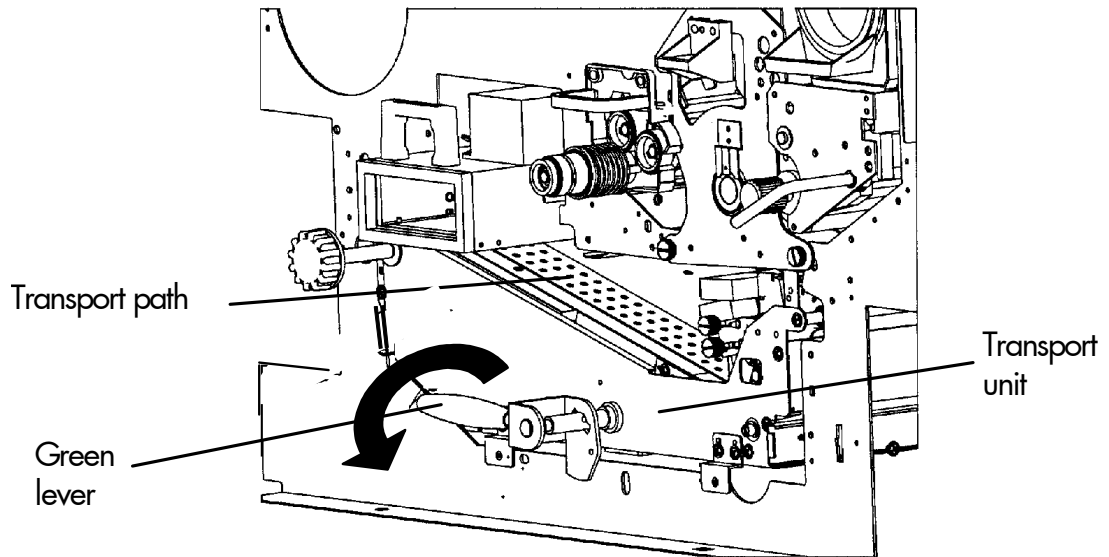

4. Look for jammed paper in the transport unit.
5. Rotate the turning knob "B" 90° clockwise (free) to set the scuff roller to the "open" condition.

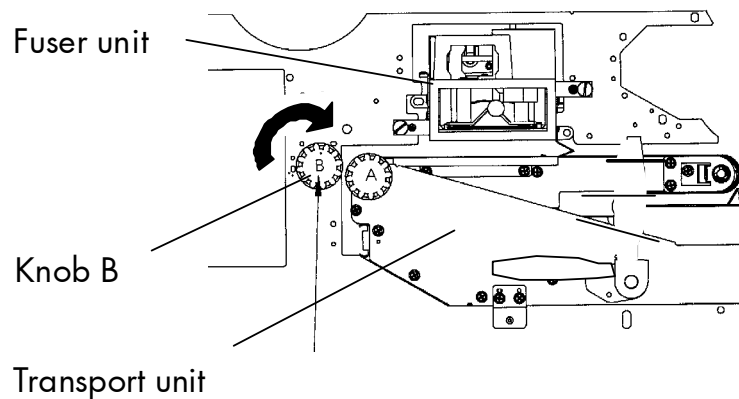

6. Detach the fanfold paper within the feeding unit at the perforation and open the paper retaining levers to remove the jammed paper.
Pull the paper out of the device only in the transport direction.

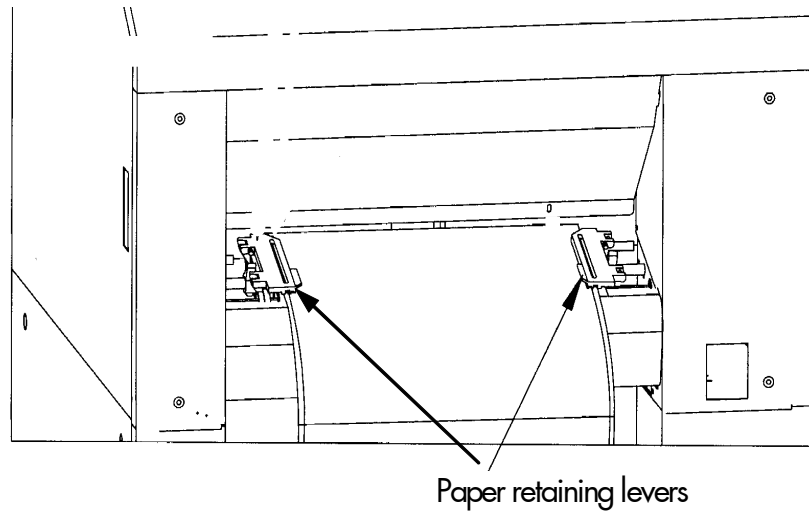

7. Detach the fanfold paper in the exit unit section at its perforation. Remove the jammed paper by pulling it out. Pull the paper out of the device only in the transport direction.

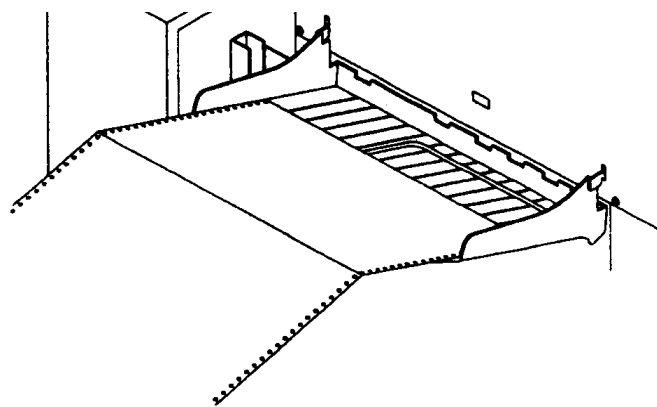

8. After having removed the jammed paper:

- Turn knob "B" 90° counterclockwise back to his original position (Lock).
- Press down the green lever to slide the transport unit into the printer until it stops while pressing down the lever (resilience at the end).
- Tip up the green lever of the transport unit to its "up" position.

Pay attention to the second bar of the transport unit located under the green lever - it also has to click into place (second bar up).

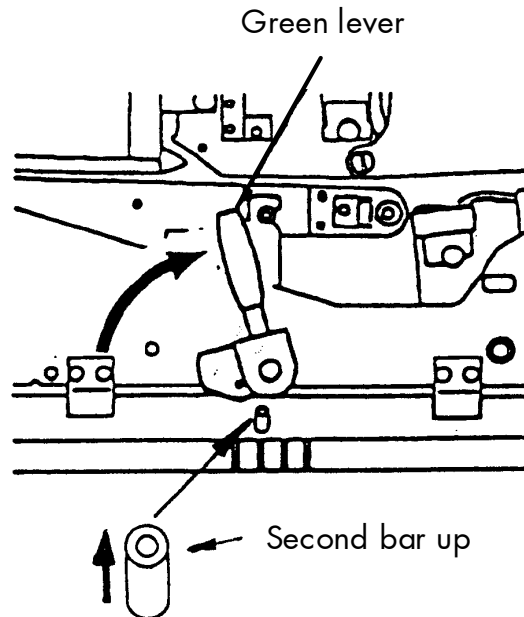



Both locks of the transport unit have to be engaged to avoid damaging the printer.

9. Close the waste toner recovery unit.



Make sure the bars have engaged.

10. Close the printer's front cover.

11. Load new fanfold paper (see section 3.1).

8.3.3. Paper Jam within the Power Stacker

There are different kind of troubles possible within the power stacker (see section 8.2.1: Further Error Messages and Error Codes, too). Frequently the folding of the paper has not worked right and so a paper jam might result.

Press the table down switch to lower the paper table. Then shift the paper table up to remove the flaw.

Sometimes it is also necessary to remove the paper from the stacker or refinish the folding at the perforation and file the paper by hand.

This error described above is displayed by the message

```
[Stacking Fail!   ]
[E0055           ]
```



To avoid paper jams the first folded edge of the fanfold paper (Perforation) has to point away from the printer. (If need be, please tear off the first page of your fanfold paper to allow the alignment shown in the following figure.) In addition do not stretch the paper excessively and do not allow any slack to avoid incorrect filing.

By this you can secure that the paper will be positioned right in the stacker.

Preview: Fanfold paper loaded in the right way



Please inform your service engineer if there are any troubles different from the one above.

8.4. Print Repetition after an Error

The printer is provided with an automatic jam safety function to prevent a loss of data.

When an error occurs, all the pages on the paper path will be printed again. This ensures that no data will get lost.

The exact number of pages to repeat depends on the format length and the position where the error occurred on the page.

This automatic jam safety function can be switched off (by changing the EEPROM - configuration) if the user wants to resume the print job at a position he chooses himself.

In addition to this see panel function Clearing the Input Buffer (section 5.6).

9. Measures for Transport and Shipping (Repacking)

The Printer is shipped with special packing material and fixing measures. It is recommended to store the boxes and those packing materials.



In case of further shipping or returning of the products they must be repacked in the original way in order to avoid damaging during transportation.

The following list gives you an overview of the working steps necessary for repacking. Pay attention to the notices located on the products and the hints given in the Service Manual as well.



If you are not familiar with any of the working steps please ask your service engineer or your supplier.

- Remove the printer's optional devices (for example: stacker ...).
- Remove the Waste Toner Bottle from the printer and seal it.
- Remove the Developer Unit.
Close carefully the toner input and output holes (using paper stripes sealed with adhesive tape, e.g.).
Put the Developer Unit into its original box.
- Remove the Drum from the printer and pack it lightproof into its original box.
- Lock all moveable parts of the printer (use all original transport safety devices, adhesive fasteners and so on).

Repack all items in their original packing material and ship them in the original boxes.

10. Specifications

Print technology:	non-impact/electrophotographic, LED, OPC, Xenon-lamp flash fusing
Print speed: (max.)	85 pages per minute (A4 portrait Two-Up)
Resolution:	300 dpi /600 dpi (in each case dots per inch horizontal and vertical)
Paper weight:	60 - 204 g/m ²
Paper size:	Width: 6 to 18 inches (appr.152 to 457 mm), 17 inches printable *) Length: 7 to 24 inches (appr.178 to 610 mm) 8 to 14 inches (using the stacker)
Stacker:	3000 sheets (64 g/m ² ; 8 to 14 inches) inside the stacker
Interfaces:	parallel: IEEE 1284 (Centronics), (MP-BUS, SPS-Control, optional) LAN: Ethernet 10/100 Mbit (TCP-IP) Optional: LAN: Ethernet (SPX-IPX, LAT), Token Ring Host: IBM SCS / IPDS (Twinax/Coax), Siemens (BAM/SS-97)
Size:	780mm (W) x 1320mm (H) x 890mm (D); incl. stacker 935mm (T)
Weight:	appr. 275 kg (including the stacker)
Environment:	Temperature: +15°C to +30°C (59°F to 86°F) (operating) -10°C to +35°C (14°F to 95°F) (non operating) Rel. atmospheric humidity: 30% to 80 % (operating) 10% to 80 % (non operating)
Mains connection:	230 V +/- 10% AC, 50 Hz Europe, United Kingdom e.g.
Power admission:	max. appr. 5.5 kVA effective (max. 0.6 kVA standby)
maximum permissible system impedance Z_{\max} :	appr. 0.02 Ohm

*) <u>Hint</u> :	Fanfold material cannot be printed in the area of the sprocket holes, even in the distance up to 5mm around the sprocket holes a reduced print quality has to be expected.
------------------	--

Costs per Page for MICROPLEX Print Systems

The term "costs per page" is the most frequently used one in connection with the purchase of a printer. Nevertheless this term is the one with the biggest lack of definition.

The distributors normally attach great importance to having small values for the costs per page. The user normally wants to have a value that is as realistic as possible.

There isn't any generally valid rule to calculate the costs per page. Therefore values given by different manufacturers are very often not comparable.

The values given by MICROPLEX are based on the utilization time of the so-called consumables of the printer. There isn't any generally valid rule for this calculation, either. Therefore MICROPLEX has fixed the definition of consumables as follows:

1. Consumables

Consumables are parts or substances which the user can exchange or refill without tools.

MICROPLEX understands by this definition that the user can decide by visible criteria when he should exchange or refill consumables. The working steps can be done by the user in accordance with the manual without the usage of tools.

Consumables can be different depending on the printer type. The most important consumable for example is **toner**.

Usually the utilization time of these materials is given as a number of pages (DIN A4). These values often refer to the print density (3%, 4%, or 5%) which is given as an application specific parameter.

Usually a value of 5% print density is defined, very seldom is 4% used.

In the case of a low print density (e.g. 3%) the utilization time increases, in the case of a high print density (e.g. 10%) the utilization time is decreased.

Therefore the utilization time is strongly dependant upon the application.

Experience proves that in professional applications a print density of higher than 5% is usually reached. For a delivery note containing a form and some bar codes a print density of 8 - 10% is quite normal.

There are further parts that must be exchanged in addition to the consumables during the life time of a print system. MICROPLEX divides these additional parts into two categories:

2. Application specific wearing materials

Application specific wearing materials are parts which have to be exchanged by a service engineer or a trained operator. The criterias for the exchange aren't always easily recognizable for a user. Some of the criterias require measuring techniques or the experience of a service engineer or operator.

In a normal application, parts of this category are:

- fuser unit
- process unit (drum, OPC)
- ozone filter

3. Spare parts

Spare parts are exchanged by the service engineer, when they fail.

Examples for spare parts are:

- couplings
- electronic assemblies
- rollers

Depending on the application some parts may change categories under certain circumstances. If for example very rough paper is used, the rollers can become an (application specific) wearing part.

It's a fact, that the right time to exchange a component depends not only on the failure of a component but also on a possible loss of print quality in the printouts.

MNPSQ = Mean Number of Prints with Specified Quality (**SQ**).

This value is often associated with "Lifetime". This term is not correct. MNPSQ describes the period of time in which a defined print quality is maintained.

The print quality is determined by the values for

- print density
- background darkness
- homogeneity

The value **IQ** (Initial Quality) is used to designate the print quality that is reached with a new printer.

CAQ (Customer Acceptable Quality) is a purely subjective lower limit which a respective customer is willing to accept the print quality. An exchange of parts is only then necessary even if the MNPSQ is already exceeded.

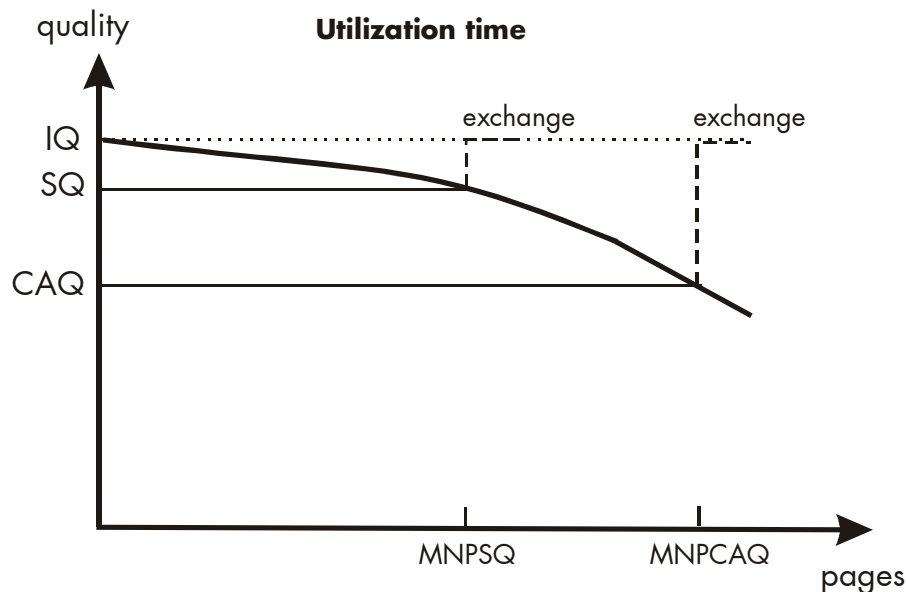

11. Index

A

auxiliary rod 125

B

background, grey 132

bar 90

basics 8

blower brush 96, 101

buffer 50

C

cancel job 50

cartridge 24

CE - conformity 10

CEE plug 15

character spacing 78

characters per inch 78

check list 13

cleaning 83, 95

cleaning brush 113

cleaning unit 18

configuration 43

configuration via control panel 36

connect, printer to a PC 31

consumables 19, 150

contents, table of 3

continuous paper 19

control panel 16, 31

control panel elements 33

control panel functions 51

control panel keys 34

controller 7

conventions 9

costs per page 150

COVER OPEN! 133

D

Data - LED 33

data interface 60

density 79

detergent 83

developer 13

developer powder 110

developer unit 13, 18, 105

diagrams 42

display 33

display language 63

disposal 27, 30, 128

DOWN key 39

drum shaft 124

drum surface 125

E

emergency power-off 12

emulations 61

environment 149

environmental conditions 15

ERROR - LED 33

error codes 136

error messages 133

extended menu 38

external view 16

F

factory default 66
fanfold paper 20, 149
feeding unit 142
first installation 13
flash fusing 7, 149
font bank 44
Font List 45
fonts 43, 47, 67
FORM FEED 49
FORM FEED key 34
FORM LENGTH key 34
format width 58
front cover 16, 84
function keys 35
functions 40
fuser unit 18
fusing 149

H

hexdump 48
humidity, relative atmospheric 15, 149

I

IDOL 13, 64
image shifting 73, 75
input buffer 50, 65
installation 13
interface, connection 15
interfaces 17, 60, 149
Interior view 18
IP address 80

K

key sequence 42
keys 9, 32
knob, turning 141, 143

L

LED announcements 33
lever 88, 90
light emitting diode 9
LINE FEED key 34
line spacing 77
lines per inch 77
Load Paper 55

M

main charger 96, 117
mains connection 149
margin 72
measures, transport 147
memory 50
memory distribution 65
MENU key 35, 40, 41
menu page 51
menu structure 38, 51

N

network parameters 80
normal print mode 49

O

ON /OFF LINE switching 37
ON LINE key 34, 39, 41
operation 31, 37
operator maintenance 95

P

packing materials 13
page description language 64
page format 56
page length 54
panel display 37, 42
panel functions 43
panel keys 32, 39
panel view 32
PAPER END! 133
paper feed 16
paper feed unit 91
paper jam 139, 140
PAPER JAM! 133
paper loading 19
paper near end sensor 20, 92
paper request 55
paper sensor 23
paper size 149
paper weight 149
paper width 58
permanent configuration changes 36, 40
photoreceptor drum 13, 122, 125
power admission 149
power input 15
power on 31, 37
power stacker 93, 145
power standards 15
power switch 16
pre-charger 100, 118
print density 151
print direction 59
print pages per page format 56
print quality 132, 151
print repeat 146
print resolution 46

print speed 7, 149
print technology 7, 149
print width 58
printable width 7
printer components 16
printer installation 14
printing basics 8

R

READY - LED 33
reduced menu 38
repacking 147
resistance, measurement 127
resolution 7, 46, 149
returning 147
roll knob 112, 113, 115

S

safety instructions 11
SAVE key 39, 40
sealing welt 108, 113
shipping 147
size 149
sliding pattern 52
spare parts 151
specifications 149
SPLIT key 34
spots of toner 132
stacker 13, 149
status sheet 43
stripes, grey 132
symbol 9
symbol code 71
syntax 42

T

temperature 15, 149
temporary configuration changes 36
TEST key 35
test prints 52
text margins 72
text orientation 70
toner 13
toner cartridge 18, 24
TONER EMPTY! 24, 134
toner roll 110
toner spindle 110
TONER WASTE! 134
tractor 16, 21, 23
tractor cover plates 21
transfer elevator drive shaft 102, 120, 122
transfer-/separator charger 102, 120
transparent code 64
transport 147
transport damages 13
transport unit 18, 88
troubles 132
troubleshooting 131
two-up mode 56

U

UP key 39
utilization time 150

W

waste toner recovery unit 18
weight 149
wire cleaning tool 98, 101, 103

