

Compuprint 4247 Serial Matrix Printers

Compuprint 4247 Model X03 Printer:
User's Guide

MAN10296.00.00



Before using this information and the product it supports, read the information in “Notices” on page 181.

First edition (October 2011)

This edition applies to the Compuprint 4247 X03 printer and to all subsequent releases and modifications until otherwise indicated in new edition.

Internet

Visit our home page: <http://www.compuprint.com>

You can send comments by e-mail to : support@compuprint.com or by mail to:

Compuprint s.r.l.
Via Lombardore 282
10040 Leinì (Turin)
ITALY

Contents

Figures	vii
--------------------------	------------

Tables	ix
-------------------------	-----------

Safety and environmental notices **xi**

Safety notices	xi
Danger hazard level	xi
Caution hazard level	xi
Attention notices	xi
Safety precautions	xii
Electrical safety	xii
Approved power cord and receptacle	xii
Electrical safety and portable power strip receptacles	xii
Connecting or disconnecting a communication port, a teleport, or an attachment connector	xiii
Servicing during an electrical storm	xiii

Preface **xv**

How to use this guide.	xv
--------------------------------	----

Chapter 1. Getting started **1**

Printer parts	2
Unpacking the printer	3
Choosing a suitable location	4
Performing a power-receptacle safety-check	5
Installing the Controller Board	5
Handling the Controller Board	5
Inserting the Controller Board	6
Installing the operator panel overlay	8
Installing the ribbon cartridge	9
Removing the ribbon cartridge	12
Power connection	13
Changing the display language (from English).	15
Loading forms in the Front Push Tractors	16
Printing your first documents	19
Installing the optional second tractor	20
Removing the optional second tractor	24
Attaching the 4247 Printer to your computer	25
Completing printer setup.	25
Software driver selection	26

Chapter 2. Understanding the operator panel **27**

Status indicators.	27
READY.	27
PROCESSING	28
ATTENTION.	28
Display panel.	28
Audible alarm	29
Custom Set In-Use Indicator.	29
Function Keys	29
MENU	30
SCROLL/MICRO↑ or SCROLL/MICRO↓	30

ENTER	31
RETURN	32
PARK/PATH	32
LINE FEED	33
LOAD/EJECT	33
FORM FEED	34
SET TOP OF FORM	35
START	35
STOP	35
CANCEL PRINT	36
TEST	36

Chapter 3. Checking and changing configuration parameter values **37**

Printing configuration defaults	37
Checking and changing parameter values	38
Exiting the Configuration Menu	39
Exiting using START	39
Exiting using RETURN	39
Locking the Printer Configuration Menu.	40
Configuration categories	40
Configuration storage	41
Attachment	41
IPDS Configuration.	41
ASCII Configuration	42
Printer setup	45
Printer adjustment	46
Power On Reset	46
Display language	47
Vital Product Data	47
Quiet Print	47
Hex Print	48
Quit From Menu	48

Chapter 4. Configuration storage **49**

Custom sets	49
Non-custom set	49
Save Current Values in Custom Sets	50
Recall Custom Set values.	51
Power-On Custom Set.	51
Power-On Paper Source	52
Recall factory defaults	53
Printing custom sets	54

Chapter 5. Attachment options **55**

Chapter 6. IPDS Configuration **57**

Characters Per Inch (CPI).	57
Lines Per Inch (LPI)	58
Maximum Print Position (MPP).	58
Maximum Page Length (MPL)	59
Print Quality	60
Print language	61
Emulation mode.	62

Media Size Priority	63
Bar Code Mode	64
Graphics Mode	65
Alarm control	66
Chapter 7. ASCII Configuration	67
Characters Per Inch (CPI).	67
Lines Per Inch (LPI)	68
Maximum Print Position (MPP).	69
Maximum Page Length (MPL)	70
Perforation skipping	71
Emulation Mode.	71
Print language	72
Print quality	74
NLQ typeface	75
Character set	75
Printer Compatibility 3 (automatic line feed on carriage return)	76
Printer Compatibility 4 (automatic carriage return on line feed)	76
Printer Compatibility 5 (form feed suppression)	77
Printer Compatibility 6 (Init)	78
Printer Compatibility 7 (condensed print)	79
Printer Compatibility 8 (slashed zero)	79
Printer Compatibility 9 (20 CPI)	80
Alarm control	81
Override host parameters	82
Paper source	82
Characters Per Inch (CPI).	83
Lines Per Inch (LPI)	84
Maximum Page Length	85
Parallel interface.	86
Interface type.	86
Input Buffer Size	86
Select-In	87
AutoFeed-XT	88
Serial interface	88
Interface type.	88
Input Buffer Size	89
Data Bits	90
Baud Rate	90
Parity	91
Pacing Control	92
Connection Type.	92
LAN Interface	93
IP Address Assignment	93
IP Address	93
Subnet Mask	94
Default Gateway	95
Host Name	95
Workgroup Name	96
SMTP Service.	97
Mail Server Address	97
E-Mail Address (Receiver)	98
E-Mail Address (Sender)	99
Chapter 8. Printer setup	101
Paper Source	101
Front Forms Backup	102
Rear Forms Backup	103

Continuous Forms Linking	104
Form Feed Mode	105
Controlling tear off operations.	106
Using automatic eject to control forms eject	106
Using automatic restore to control restoring of forms	106
Automatic Eject	107
Automatic Restore.	108
Continuous Forms Eject Mode.	109
Bar Code Print Direction	110
Graphics Print Direction	111
Perforation Safety	112
Jam Sensors	113

Chapter 9. Printer adjustments	115
Paper-Load-Position to Tear-Position relationship	115
Front Automatic Forms Thickness Adjustment (AFTA)	116
Front Tear Position	116
Front Left Margin Alignment	117
Front Paper Load Position	117
Rear Automatic Forms Thickness Adjustment (AFTA)	118
Rear Tear Position	118
Rear Left Margin Alignment	119
Rear Paper Load Position	120
Bidirectional Adjustment	120
Sensor Tune	121
Quit From Menu	121

Chapter 10. Power-On Reset (POR) 123

Chapter 11. Display Language 125

Chapter 12. Vital Product Data 127

Serial Number	127
Device Specific Information	128

Chapter 13. Quiet Print 129

Chapter 14. Hex Print 131

Chapter 15. Quit From Menu 133

Chapter 16. Dual push tractor forms paths 135

Introduction	135
Forms selection.	135
Using different forms on two paths	136
Setting up printer	136
Using path switching.	136
Using same forms on both paths (linking)	137
Setting up printer	137
How forms linking works	138
Parking one continuous form and loading another	138
Parking a continuous form	138
Changing the forms path	138

Chapter 17. Using the Operator Print Tests	139
General test instructions	139
Quick Reference	140
Printer Demonstration	140
Printer Configuration	141
Print Custom Sets	141
Firmware Information	142
Printer Adjustments	142
Chapter 18. Supplies, optional features, and maintenance	145
Continuous forms specifications	145
Proper forms loading	146
Forms Handling Paper Paths	147
Forms stacking recommendations	147
Forms stack input and output locations	147
Supplies	148
Optional features	148
Maintenance	149
Removing the ribbon cartridge	149
Cleaning the printer	149
Chapter 19. Problem solving	151
Using status code and problem listings	151
Status code and messages displays	151
No status code displays	151
Status codes and recovery actions	152
Problem list index	156
Forms problems	159
Print quality and ribbon problems	160
Configuration problems	162
Miscellaneous problems	162
Clearing forms jams	163

Appendix A. Printer specifications	165
General information	165
Operating and service clearance	166
Weight	166
Power consumption	166
Heat output	166
Airflow	167
Declaration of product noise emission values	167
The Parallel Interface	167
Parallel connector pin assignments	167
The Serial Interface	168
RS-232C connector pin assignments	168
The LAN Interface	169
LED indicators	169
Environmental requirements	169
Operating environment	169
Shipping environment	169
Storage environment	170
Electrical requirements	170
Power cord	170
Safety	171
Branch circuits and grounding	171

Appendix B. 4247 Model X03 - Configuration Menu	173
--	------------

Appendix C. Printer driver support	175
IBM pSeries AIX colon files	175
IBM System i workstation customization objects	175

Index	177
--------------	------------

Notices	181
----------------	------------

Figures

1. Printer Parts: Front and Rear View	2	23. Adjusting the right sprocket	19
2. Contents of Shipping Container	3	24. Closing the Push tractors cover.	19
3. Removing the shipping locks from the printer.	4	25. Opening the tractor area cover.	20
4. Printer clearances.	4	26. Second tractor.	21
5. Removing the two screws on the metal plate.	6	27. Aligning the second tractor hooks.	21
6. Sliding the board in the slot.	7	28. Connecting the second tractor	22
7. Attaching the Controller Board.	7	29. Rotating the tractor gear protection cover.	22
8. Operator panel.	8	30. Second tractor in the closed position.	23
9. Ribbon Cartridge	9	31. Paper path direction	23
10. Opening the top cover	10	32. Disconnecting the second tractor.	24
11. Aligning the cartridge pins.	10	33. Closing the protection cover.	24
12. Print head and ribbon guide mask showing correct positioning of the ribbon.	11	34. 4247 Printer Operator Panel	27
13. Positioning the snap arm.	11	35. Correctly Loaded Paper	146
14. Aligning the ribbon mounting pins.	12	36. Forms Handling Paper Paths	147
15. Inserting the power cable plug	13	37. Forms stacking recommendations.	147
16. Power switch in the I position (ON).	13	38. Forms stacking recommendations.	148
17. Opening the Push tractors cover	16	39. Freeing the shifter holder	149
18. Unlocking the sprockets of the Front1 push tractor	16	40. Rotating the bail assembly	163
19. Opening the left and right sprocket covers.	17	41. Gripping the bail assembly	163
20. Closing the left sprocket cover.	17	42. Inserting the left and right paper bail end cap pivots into the side frames	164
21. Inserting the paper on the right sprocket pins.	18	43. Printer clearances.	166
22. Matching the left sprocket for the first printing position.	18		

Tables

1. Configuration Storage Category	41	18. Forms do not feed past printhead.	156
2. Attachment Category	41	19. Forms do not stack correctly	156
3. IPDS Configuration Category	41	20. Characters off registration	157
4. ASCII Configuration	42	21. Unreadable characters.	157
5. Printer Setup	45	22. Missing dots or irregular characters	157
6. Printer Adjustment	46	23. Ribbon smudging forms	157
7. Power On Reset	46	24. Printing is too light or partial characters print	157
8. Display Language	47	25. Ribbon snagging, tearing, or not moving	157
9. Vital Product Data Category	47	26. Line-to-line horizontal misregistration	158
10. Quiet Print Category	47	27. Printer doesn't print or prints wrong	
11. Hex Print Category	48	characters.	158
12. Quit From Menu Category	48	28. Printer has no power	158
13. Supported Print Languages	61	29. Throughput of printer at half speed	158
14. Single Path Usage recommendations	107	30. Sound Emission Levels - with Standard	
15. Dual Path Usage recommendations	107	Covers.	167
16. Display Languages.	125	31. RS232/C serial interface signals	168
17. Forms buckle, twist, jam, or tractor holes tear	156		

Safety and environmental notices

Safety notices

There are two levels of safety notices: **Danger** and **Cautions**.

Danger hazard level

The word **Danger** indicates the presence of a hazard that has the potential of causing death or serious personal injury.

Most **DANGER** notices are numbered <1-1>, <1-2>, and so forth where they appear in the text of this manual.

Example of a **Danger** notice:



DANGER

<1-10> Hazardous voltages are present. Do not touch the pins or sockets of the power receptacle.

Caution hazard level

The word **Caution** indicates the presence of a hazard that has the potential of causing moderate or minor personal injury.

Most **CAUTION** notices are numbered <2-1>, <2-2>, and so forth where they appear in the text of this manual.

Example of a **Caution** notice:



CAUTION:

<2-22> Carefully follow all cleaning instructions, using only the materials and solutions recommended.

Attention notices

The word **Attention** calls attention to the possibility of damage to a program, device, system, or data.

Attention notices are not numbered.

Examples of an **Attention** notices:

Attention: This printer has nominal AC input power requirements (see Appendix A, "Printer specifications," on page 165).

Safety precautions

Electrical safety

This printer is inspected and listed by recognized national testing laboratories, such as Underwriters Laboratories, Inc. (UL) in the U.S.A. and Canadian Standards Association (CSA) in Canada. Listing of a product by a national testing laboratory indicates that the product is designed and manufactured in accordance with national requirements intended to minimize safety hazards. This equipment meets a very high standard of safety in design and manufacture. Remember, however, that this product operates under conditions of high electrical potentials and heat generation, both of which are functionally necessary.

Because the paper used in the printer can burn, you should take normal precautions to prevent fire. These precautions include common-sense measures, such as keeping potentially combustible materials (for example, curtains and chemicals) away from the printer, providing adequate ventilation and cooling, limiting unattended operation, and having trained personnel available and assigned to the printer.

Approved power cord and receptacle



DANGER

<1-11> Your country may require an approved power cord and plug. Ensure that you have the correct power cord and plug. Use this cord and plug only with an approved, correctly-installed power receptacle.

Electrical safety and portable power strip receptacles

Extension cords



DANGER

DANGER<1-1> Do not use an extension power-cord.

The customer must supply the correct electrical outlet which must meet the requirements stated under Appendix A, "Printer specifications," on page 165.

Portable power strip receptacles (temporary power taps)

Portable power strip receptacles (referred to as "temporary power taps" by the National Electrical Code) may be used if they are fully approved in the customer's geographic location. It is the customer's responsibility to supply a fully approved "temporary power tap", if one is to be used.

Connecting or disconnecting a communication port, a teleport, or an attachment connector



DANGER

<1-14> Switch off printer power and unplug the printer power cord before connecting or disconnecting a communication port, a teleport, or other attachment connector.

Servicing during an electrical storm



DANGER

<1-13> Do not connect or disconnect a communication port, a teleport, or any other connector during an electrical storm.

Preface

This guide describes the basic operating procedures for the 4247 Model X03 printer. This information is useful to those who install or operate the printer, or for those who supervise printer operations.

You need only basic operating experience to use this printer. This experience includes an understanding of how printers work, how to connect cables, and how to select items from an operator panel menu.

How to use this guide

The following list describes the contents of each chapter and the appendixes in this book.

- Chapter 1, "Getting started," provides information on setting up the printer and connecting it to the host computer.
- Chapter 2, "Understanding the operator panel," describes the operator panel and how to use it.
- Chapter 3, "Checking and changing configuration parameter values," describes the configuration parameters and values and gives you a brief description and procedure for changing them.
- Chapter 4, "Configuration storage," provides information on saving configuration parameters into a custom set for your printer. The configuration storage category has eight available custom sets.
- Chapter 5, "Attachment options," provides the procedure for setting the configuration for printer attachment.
- Chapter 6, "IPDS Configuration," describes how to check and change IPDS™ configuration parameters for your 4247 printer.
- Chapter 7, "ASCII Configuration," describes the procedures for checking and changing parameter values for parallel and serial attachments.
- Chapter 8, "Printer setup," describes the procedures for checking and changing the parameter values in the configuration menu for the printer setup category.
- Chapter 9, "Printer adjustments," describes the parameters for checking and changing the parameter values in the configuration menu for the printer adjustment category.
- Chapter 10, "Power-On Reset (POR)," describes the procedure to perform a power-on reset for your printer.
- Chapter 11, "Display Language," provides information on the display languages shipped with your printer.
- Chapter 12, "Vital Product Data," provides information to check and change some of the vital product data for the printer.
- Chapter 13, "Quiet Print," describes the procedure to set the Quiet Print mode for your printer.
- Chapter 14, "Hex Print," describes the procedure to set the Hex Print mode for your printer.
- Chapter 15, "Quit From Menu," describes the procedure to quit from the configuration menu and restore the previous configuration menu values.
- Chapter 16, "Dual push tractor forms paths," describes forms and paper loading, and running a print job through the six different paper paths.

- Chapter 17, "Using the Operator Print Tests," describes procedures for testing and adjusting the printer.
- Chapter 18, "Supplies, optional features, and maintenance," provides the information you need for ordering new supplies, replacing damaged or worn ribbons, and available printer options.
- Chapter 19, "Problem solving," describes how to diagnose and solve printer problems. Always start your problem determination procedure with this chapter.
- Appendix A, "Printer specifications," contains general printer information and planning requirements. It also contains information on the electrical and environmental requirements, cabling information, and forms specifications.
- Appendix B, "4247 Model X03 - Configuration Menu," contains a hierarchical representation of the Configuration Menu.
- Appendix C, "Printer driver support," on page 175 contains information about downloading drivers for your printer.

Chapter 1. Getting started

Printer parts	2	Removing the ribbon cartridge	12
Unpacking the printer	3	Power connection	13
Choosing a suitable location	4	Changing the display language (from English).	15
Performing a power-receptacle safety-check	5	Loading forms in the Front Push Tractors	16
4247 Model X03 nominal AC input power		Printing your first documents	19
requirements	5	Installing the optional second tractor	20
Installing the Controller Board	5	Removing the optional second tractor	24
Handling the Controller Board	5	Attaching the 4247 Printer to your computer	25
Inserting the Controller Board	6	Completing printer setup.	25
Installing the operator panel overlay	8	Software driver selection	26
Installing the ribbon cartridge	9		

This chapter guides you through setting up your 4247 Model X03 printer. The partial table of contents at the beginning of the chapter shows the procedures involved in this setup process. Refer to this list for specific procedures and page locations.

Perform Each Step in Order
Complete each step before you start the next one. If you cannot successfully complete all of the following steps, call your place of purchase.

Printer parts

Front View

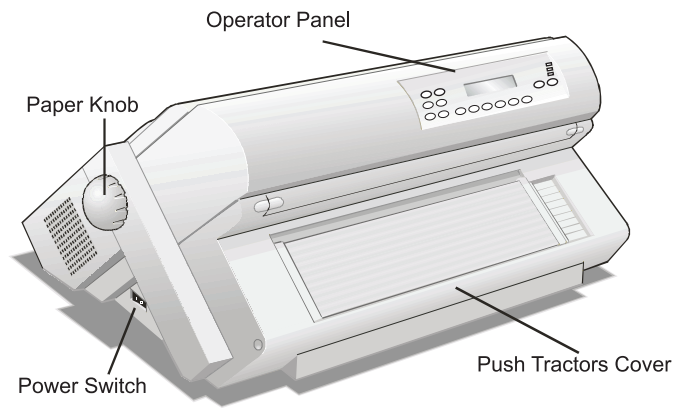

Rear View

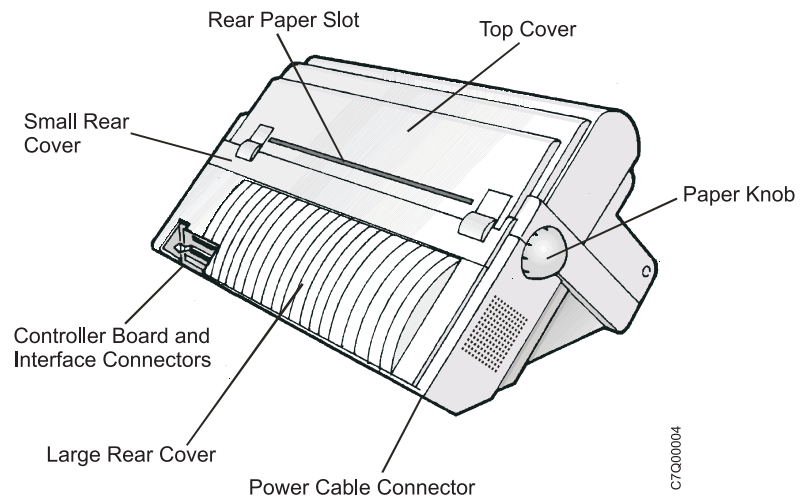

Figure 1. Printer Parts: Front and Rear View

Unpacking the printer



CAUTION:

The 4247 printer weighs 21 kg (46 lbs). Two persons are required to lift it.

1. Review the following list of contents as you unpack the shipping container. Contact your point of purchase if any items are missing.
 - • Printer
 - • One forms tractor (and optional second tractor)
 - • Ribbon cartridge
 - • Documentation and CD
 - • Controller Board (do not remove from protective package)
 - • Operator panel overlay
 - • Power cable
 - • CD Rom

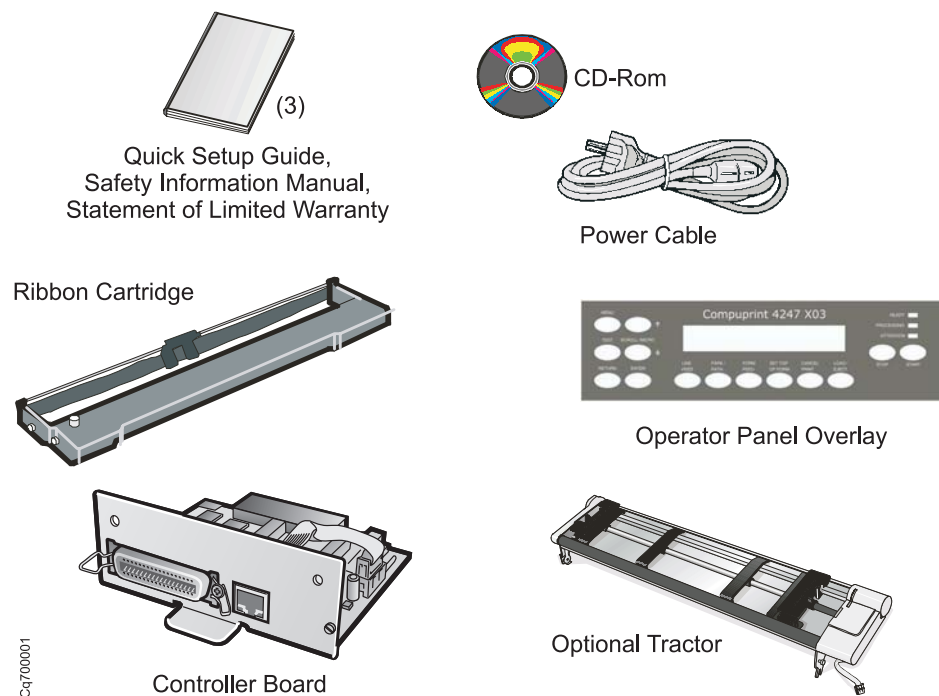

Figure 2. Contents of Shipping Container

Additionally, you can order the following option (not pictured here).

- Printer Stand - Provides adequate printer support, and especially helpful when using the Dual Push forms path
2. After opening the shipping container, have another person help you remove the printer and place it on a table or the optional printer stand. If you select a table as the permanent location, ensure:
 - You have access to both the front and the rear of the printer.
 - The table you select is sturdy enough to support the weight of the printer, and firm enough to contain the action of the printer movement. To meet this criteria, We recommend the optional printer stand which is available from your marketing representative.

3. Remove the remainder of the contents from the shipping container. (See Appendix A, "Printer specifications" for dimensions of the table or printer stand surface and the clearances required around the printer.)
4. If you have not already done so, remove the plastic bag from the printer.
5. Lift the bottom edge of the front tractor cover into the open position.
6. Remove the shipping locks from the printer.

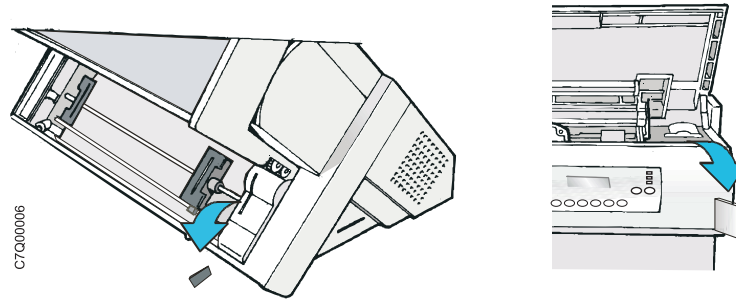

Figure 3. Removing the shipping locks from the printer.

Choosing a suitable location



CAUTION:

The 4247 printer weighs 21 kg (46 lbs). Two persons are required to lift it.

Consider the following points when you choose the location for your printer:

- The distance between the printer and the host computer must not exceed the length of the interface cable. The location must be sturdy, horizontal and stable
- Your printer must not be exposed to direct sunlight, extreme heat, cold, dust or humidity (see Appendix A, "Printer specifications," on page 165.
- You need a power outlet compatible with the plug of the printer's power cord.
- For best continuous forms stacking, the forms should be stacked on the floor or on a surface below the base of the printer.
- For successful forms parking, the input forms stack *must* always be lower than the base of the printer.

There must be sufficient clearances on all sides for easy operation. The required space is shown in the following figure:

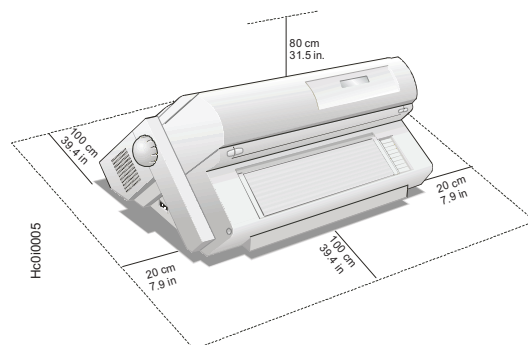

Figure 4. Printer clearances.

Performing a power-receptacle safety-check



DANGER

<1-10> Hazardous voltages are present. Do not touch the pins or sockets of the power receptacle.

For pluggable equipment, the socket-outlet shall be installed near the equipment and shall be easily accessible.

“Portable power strip receptacles (temporary power taps)” on page xii, conforming to all requirements, may be used.

A qualified electrician should perform all checks necessary to ensure safe operation. These should include the following checks and any other required by local regulations.

- Check the AC voltage at all associated power receptacles (see “4247 Model X03 nominal AC input power requirements”).
- Check the AC impedance to ground at all associated power receptacles.

Attention: If the voltages are not within the correct operating range, allow correction before the equipment is plugged in and operated.

4247 Model X03 nominal AC input power requirements

Nominal Voltage	Voltage Range	Amps	Phase / Hz
100–230 Vac	90–264 Vac	3.8–1.6 A	Single phase / 50–60 Hz

Installing the Controller Board

The 4247 printer arrived with the Controller Board that you ordered.

You must install the Controller Board (received with the printer) into the proper slot in the back of the printer before it can be used.

Handling the Controller Board

Attention: Do not remove the Controller Board from the protective package until instructed to do so. Static electricity, though harmless to you, can damage sensitive Controller Board components. Use the information in this section to avoid damaging a Controller Board.

- Limit your movement. Your movement can create static electricity that, when released to the Controller Board, can damage the electronic components on the Controller Board. Sliding your foot across carpeting is an example of how you create unwanted static electricity.
- Handle the Controller Board only by the edges and prevent others from making direct contact with it.
- Before removing the Controller Board from the protective package, ground the package to exposed metal at the back of the printer. This will release any static

charge that may have developed on the package or on your body. Hold the package against the metal for at least two seconds.

- When you are instructed, remove the Controller Board and install it directly into the Controller Board slot without setting it down. If you have removed the Controller Board from the protective package and cannot immediately insert it in the printer, place the protective package on a flat surface, and set the Controller Board on top of the protective package.

Inserting the Controller Board

Attention: Ensure that the printer is powered off before installing or removing the Controller Board.

If the Controller Board is installed while the printer is powered on, the controller will not synchronize with the printer mechanism board. Unpredictable printer behavior will result.

Perform the following steps to install the Controller Board:

1. Ensure that the printer is powered off. Installing the Controller Board with the printer power on will result in unpredictable printer behavior.
2. Use the screwdriver that came in the Controller Board box to remove the metal plate on the back of the printer by unscrewing the two screws.

Note: Save the two screws as you need them to attach the Controller Board to the back printer. Save the metal plate for reuse if the Controller Board is removed.

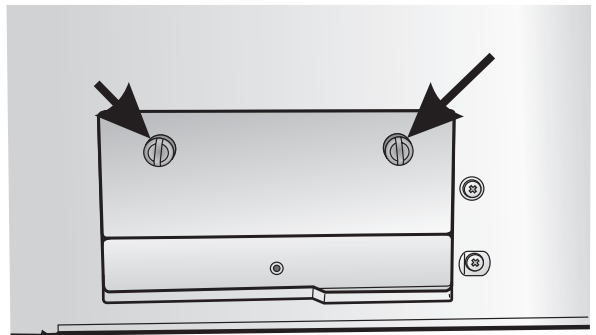

Figure 5. Removing the two screws on the metal plate.

3. Use the information under “Handling the Controller Board” on page 5 as you remove the Controller Board from its shipping box and from the protective package.
4. Align the left and right sides of the Controller Board with the guides in the printer and slide it into the slot.

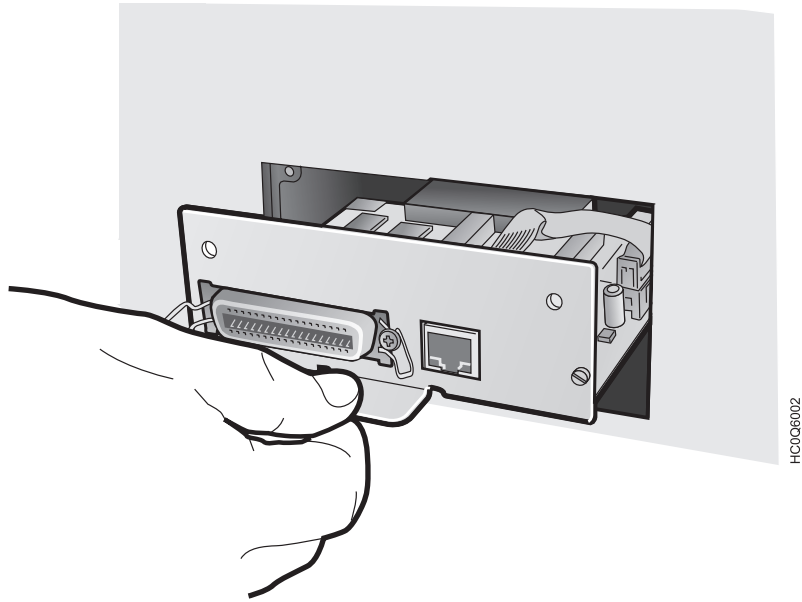

Figure 6. Sliding the board in the slot.

5. Gently push the Controller Board into the printer until it is seated in the connector inside the printer. The Controller Board is correctly seated in the printer when the Controller Board metal plate is aligned with the back profile of the slot.
6. Attach the Controller Board with the two captured screws using the screwdriver that came in the Controller Board box.

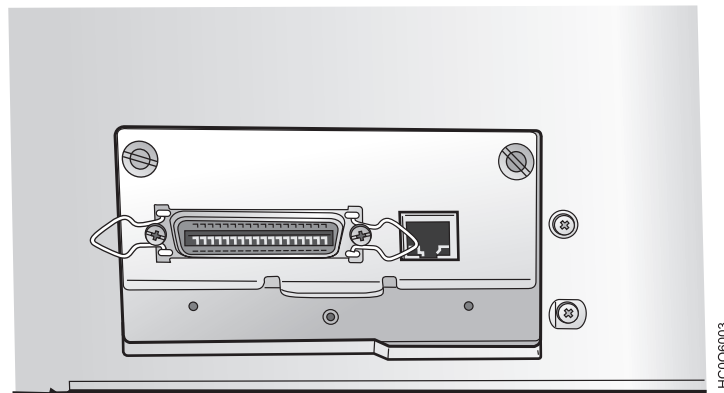

Figure 7. Attaching the Controller Board.

Installing the operator panel overlay



Figure 8. Operator panel

1. Remove the protective film from the printer operator panel display.
2. Remove the paper backing from the reverse side of the operator panel overlay.
3. Align the bottom of the overlay and align both sides. Ensure that the placement you choose for the overlay will allow free movement of the operator panel keys.
4. After being satisfied with the placement, press the overlay in place starting at the bottom below the keys, and continue working upwards until the overlay is pressed into place.

Installing the ribbon cartridge

It is recommended that you use an approved ribbon cartridge. To install the ribbon cartridge, follow these steps:

1. Remove the ribbon cartridge from the package. Locate the ribbon guide, snap arm, ribbon advance knob, and the ribbon mounting pins.

To avoid damage to the ribbon, do not turn the winding knob in the wrong direction.

2. Turn the ribbon advance knob in the direction of the arrow to take up any slack in the ribbon. If the ribbon does not move, contact your place of ribbon purchase to replace the ribbon cartridge.

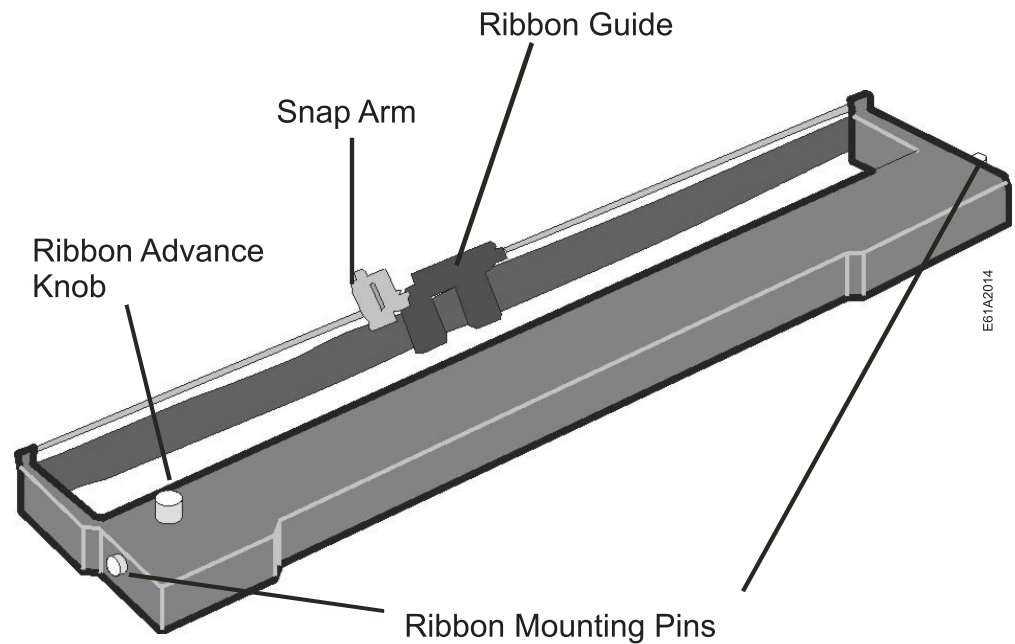

Figure 9. Ribbon Cartridge

3. Open the top cover using the small handles on either side of the top cover.

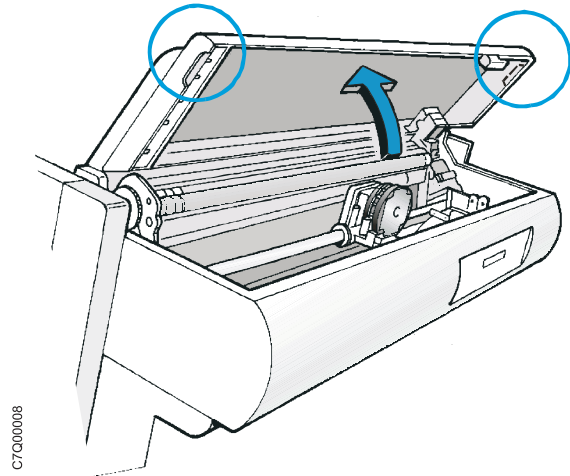

Figure 10. Opening the top cover

4. Slide the print head to the center of the printer.
5. Align the cartridge pins with the locking grooves on the left and right cartridge supports.

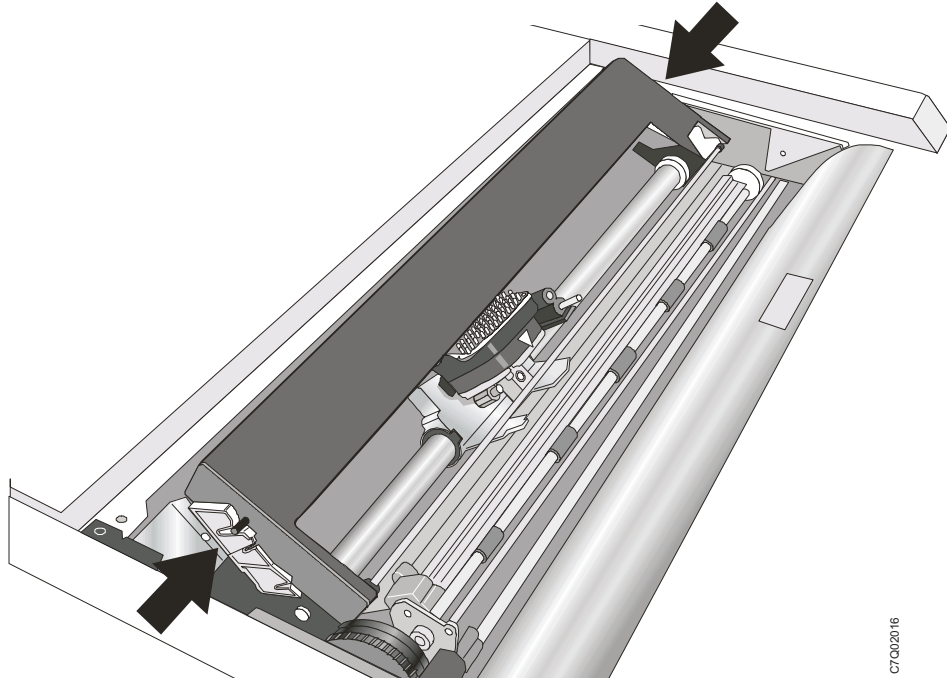

Figure 11. Aligning the cartridge pins.

6. Position the ribbon guide over the printhead, holding it perpendicular to the print head.

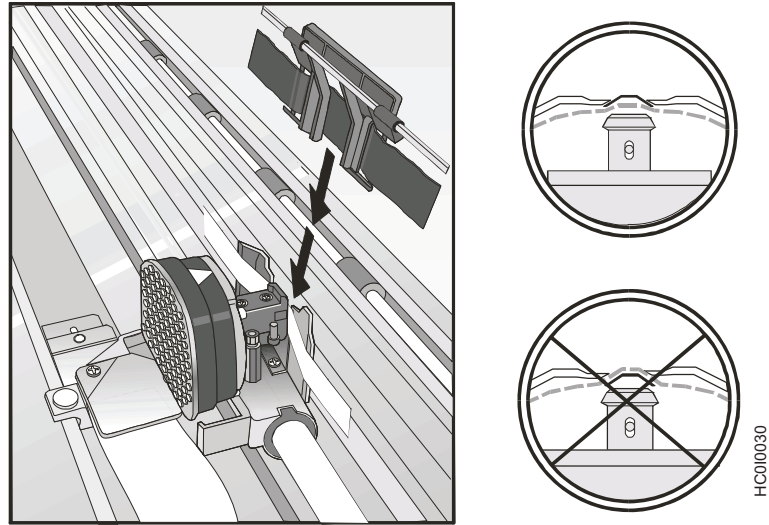

Figure 12. Print head and ribbon guide mask showing correct positioning of the ribbon.

7. Turn the ribbon advance knob to take up any slack in the ribbon.
8. Position the snap arm with the small lever up onto the ribbon lift assembly. Push the snap arm down onto the ribbon lift assembly until it snaps into place.

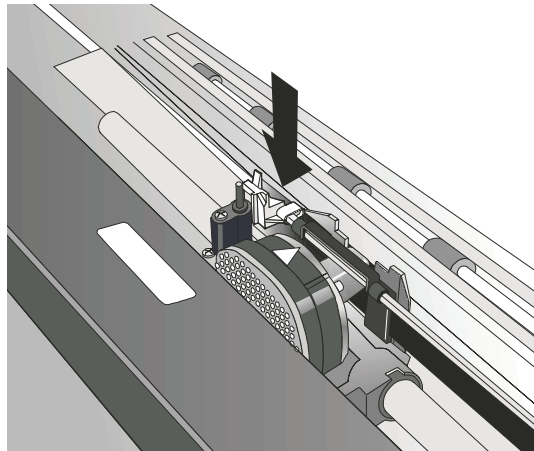

Figure 13. Positioning the snap arm.

9. Align the ribbon mounting pins on the left and right side of the ribbon cartridge with the slots in the cartridge supports. Snap the ribbon cartridge down into place.

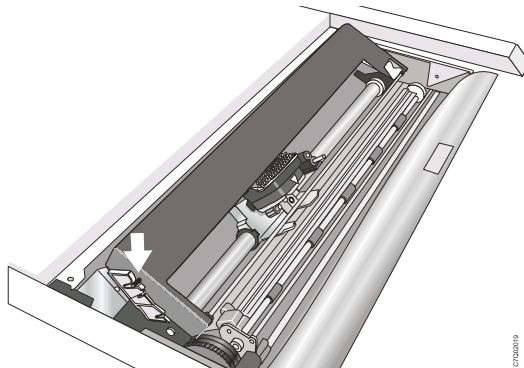

Figure 14. Aligning the ribbon mounting pins.

10. Turn the ribbon advance knob again in the direction of the arrow to take up any slack in the ribbon, as you slide the printhead back and forth to ensure that the ribbon guide runs freely along the ribbon.
11. If the ribbon is not running freely, or to ensure that you have installed the ribbon cartridge correctly, ensure that:
 - a. The left and right ribbon mounting pins are securely snapped into the cartridge supports.
 - b. There are no twists or folds in the ribbon.
 - c. The ribbon is not catching on the printhead.
 - d. The ribbon moves when you turn the ribbon advance knob in the direction of the arrow. If the ribbon does not move, replace the ribbon cartridge. Contact your place of ribbon cartridge purchase if you believe that the ribbon is faulty.
12. Close the top printer cover.

Removing the ribbon cartridge

See "Removing the ribbon cartridge" on page 149 for instructions on this procedure.

Power connection



DANGER

<1-11> Your country may require an approved power cord and plug. Ensure that you have the correct power cord and plug. Use this cord and plug only with an approved, correctly-installed power receptacle.

1. Make sure the power outlet is near the printer location and easily accessible.
2. Make sure that the power switch is in 0 position (OFF).
3. Insert the power cable plug into the printer connector and the other power cable end into a convenient outlet.

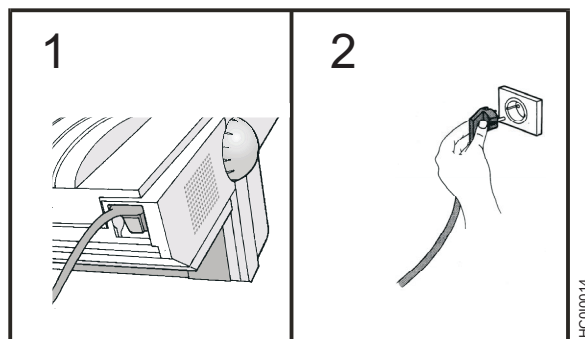

Figure 15. Inserting the power cable plug

4. Turn the printer on, press the power switch in the I position (ON).

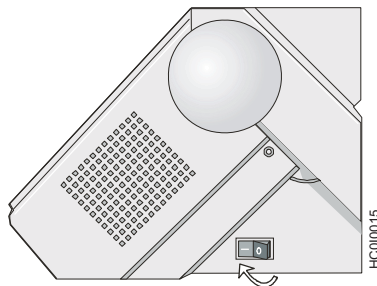

Figure 16. Power switch in the I position (ON).

Attention: If, for any reason, the Controller Board was not correctly installed in the printer, the printer will not work and the following audio/visual symptoms will occur:

- The buzzer sounds continuously
- The Operator Panel display is partially filled with solid black boxes
- The Operator Panel LEDs are all lit.

If this is the case, power off the printer, re-seat the Controller Board, and power the printer on again.

Note: If the printer does not show the correct display sequence, go to the status code section of “Using status code and problem listings” on page 151. Follow the instructions for the status code shown on the display panel.

Changing the display language (from English)

The printer is delivered with English as the default language. Follow this procedure to change the language in which messages and menu items will appear in the operator panel display.

1. Press **MENU** to enter configuration.
2. Press **SCROLL/MICRO↑** or **SCROLL/MICRO↓** until the printer displays:

```
CONFIGURATION MENU
Display Language
```

3. Press **ENTER** to display the current value.
4. Press **SCROLL/MICRO↑** or **SCROLL/MICRO↓** until the language you want is displayed.
5. Press **ENTER**. An asterisk (*) will be displayed in front of the selected value.
6. Press **RETURN** to return to the Configuration Menu.
7. Press **START**. The printer displays:

```
Press ENTER to Save
Press START to Not Save
```

8. Choose between one of these options:
 - If you want to use the selected display language as the printer default for this session only (the printer will use the existing defaults the next time it is powered on), press **START**. The printer will exit the menu and become *ready*.
 - **OR**
 - If you want to keep the selected display language as the printer default, press **ENTER**. The printer displays:

```
Save Current Values
Custom Set A
```

9. Press **ENTER**.
10. Press **START** again. The printer will exit the menu and become *ready*.

Loading forms in the Front Push Tractors

This sequence describes how to load the fanfold paper with the push tractor (default).

1. Turn the printer on.
2. Open the Push tractors cover turning it upwards and lay it on the top of the printer.

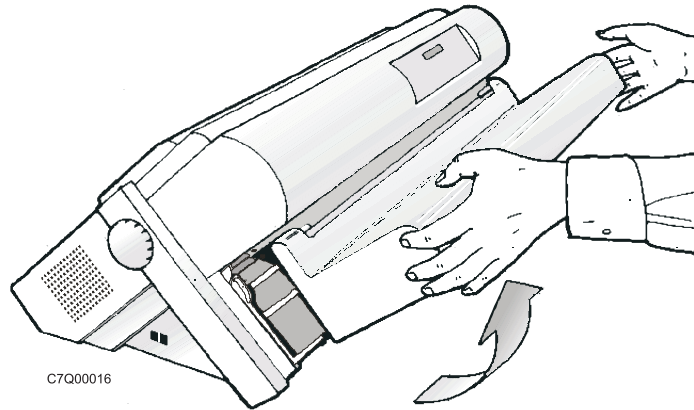

Figure 17. Opening the Push tractors cover

3. Unlock the tractors by moving the sprocket levers to the up position. Slide the left tractor to the left.

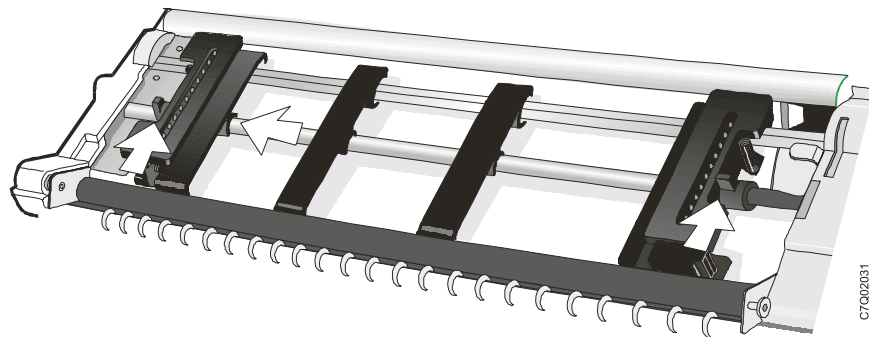

Figure 18. Unlocking the sprockets of the Front1 push tractor

4. Space the paper guides along the tractor bar. Open the left and right sprocket covers.

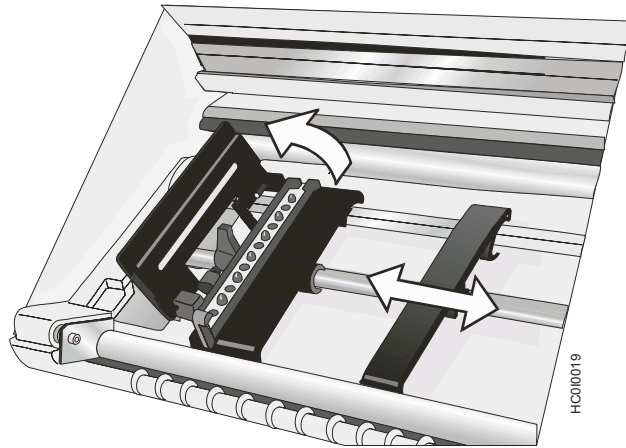

Figure 19. Opening the left and right sprocket covers.

5. Hold the fanfold paper in front of the sprockets and insert the paper perforation on the left sprocket pins and close the left sprocket cover.

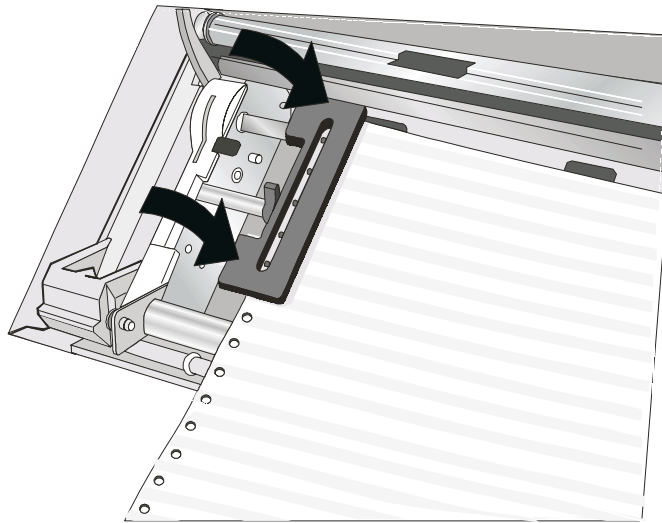

Figure 20. Closing the left sprocket cover.

6. Insert the paper on the right sprocket pins.

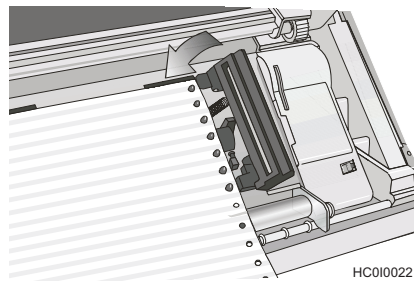

Figure 21. Inserting the paper on the right sprocket pins.

7. Match the left sprocket for the first printing position, that is the left margin must match the 9th mark on the printer cabinet.

Note: Aligning the left-hand edge of the paper past the 22nd spacer on the printer cabinet will cause the paper to be misaligned with the Paper Load Sensor resulting in a '001 End of Forms' error.

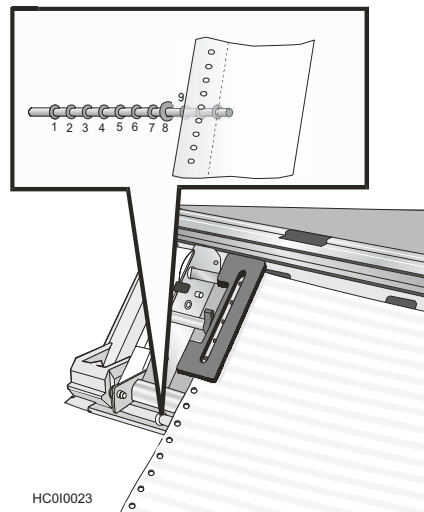

Figure 22. Matching the left sprocket for the first printing position.

- Adjust the right sprocket gently to remove slack from the paper. Lock the left and right sprockets moving the sprocket levers to the up position.

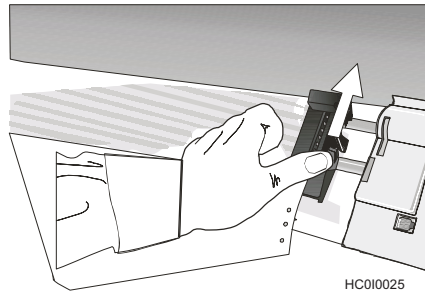

Figure 23. Adjusting the right sprocket

- Close the Push tractors cover.

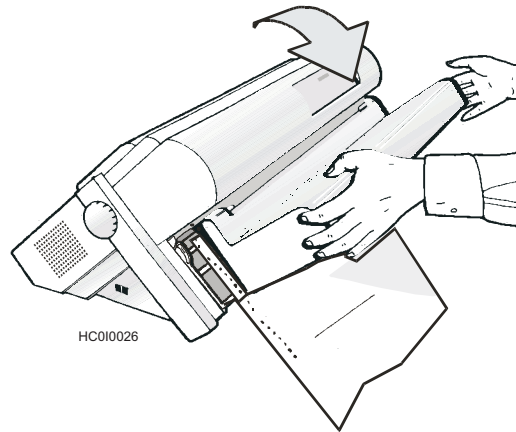



Figure 24. Closing the Push tractors cover.

- Press the **STOP** key to take the printer **Not Ready**.
- Press the **LOAD/EJECT** key to load the paper into the printer.
- Press the **START** key to put the printer **READY**.

Printing your first documents

The Quick Reference is a popular print test that may help familiarize you with the operator panel keys and the configuration menu you can set. The Quick Reference printout allows you to check print quality and printer operations.

- Each key is listed with a corresponding description to the right.
 - Each parameter is shown with the corresponding values you can select printed to the right.
- Ensure that the printer is offline. If the printer is *ready*, press **STOP** to make the printer *not ready*.
 - Press **TEST**.
 - Press **SCROLL/MICRO**  or **SCROLL/MICRO**  until the printer displays:

OPERATOR PRINT TESTS
Quick Reference

4. Press **ENTER** or **START** to print this test. The **READY** indicator comes on and printing begins. Press **STOP** if you want stop the Print Test before it completes printing.
5. Wait for the printer to stop printing and the **READY** indicator to go off.
6. Press **FORM FEED** until you can remove the printout. The printout should be clear and readable.

YOU HAVE JUST COMPLETED A SETUP AND CHECKOUT OF THE PRINTER.

We recommend that you now print your printer configuration defaults. Save this printout for future reference. You can create a printout of the printer configuration by following these steps:

1. Press **SCROLL/MICRO** or **SCROLL/MICRO** until the printer displays:

OPERATOR PRINT TESTS
Print Custom Sets

2. Press **ENTER** or **START** to print this test. See “Print Custom Sets” on page 141 for more information about this printout.
3. To exit Print Test, press **RETURN** to make the printer *not ready* or **CANCEL PRINT** to make the printer *ready*.

Installing the optional second tractor

A second optional tractor is available for your printer. This tractor may be installed on the first (standard) front tractor.

1. Open the tractor area cover.

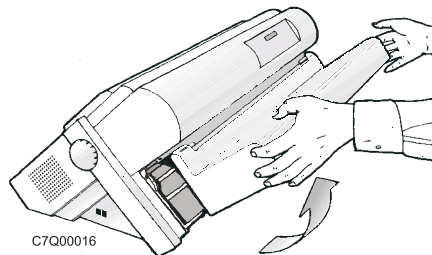

Figure 25. Opening the tractor area cover.

2. Unpack the second tractor.

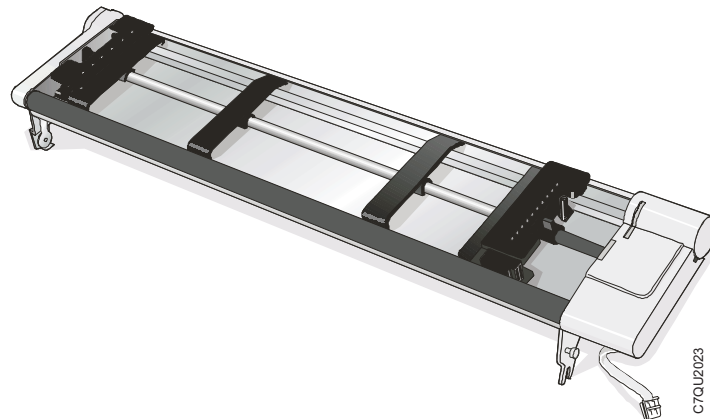

Figure 26. Second tractor

3. Align the hooks on both sides of the second tractor with the pins on the first tractor. Push the second tractor on the pins until it is fully engaged.

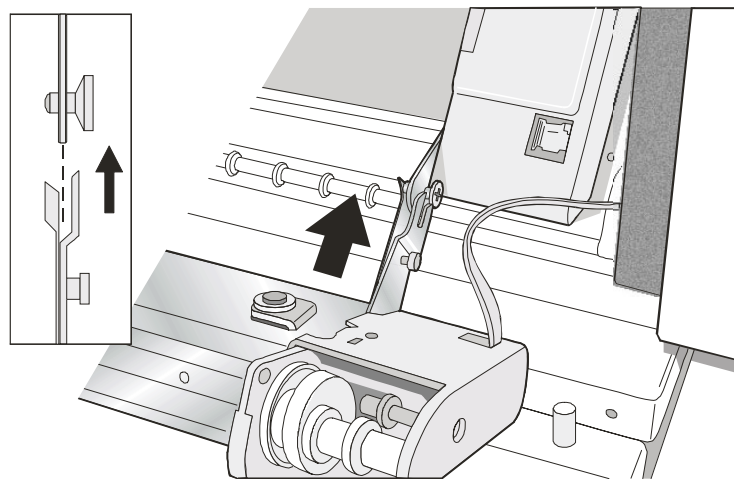

Figure 27. Aligning the second tractor hooks.

4. Connect the second tractor to the first using the electrical cable/connector provided on the tractor.

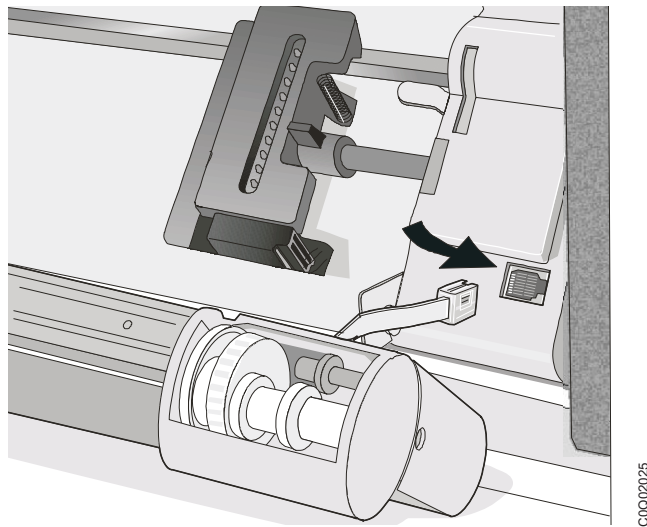

Figure 28. Connecting the second tractor

5. Rotate the tractor gear protection cover downwards to free the gear.

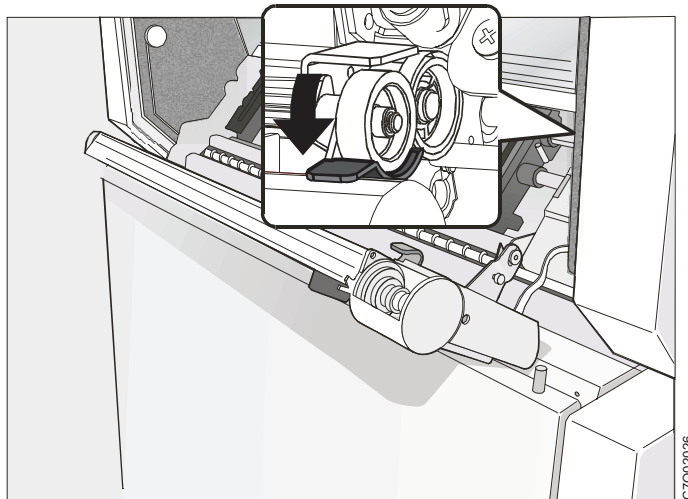

Figure 29. Rotating the tractor gear protection cover.

6. Rotate the second tractor into the closed operating position.

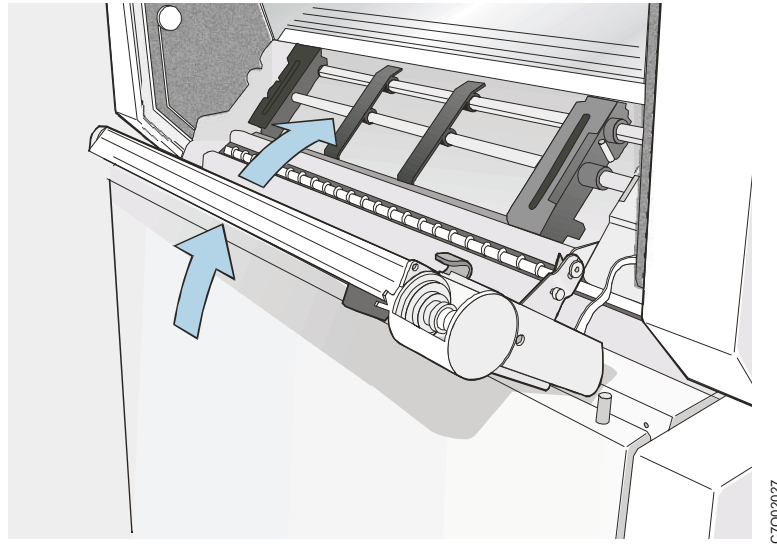

Figure 30. Second tractor in the closed position.

7. To load paper onto the first tractor when the second tractor is installed, rotate the second tractor out and insert paper between the two tractors. (See "Loading forms in the Front Push Tractors" on page 16 for paper loading procedures.)

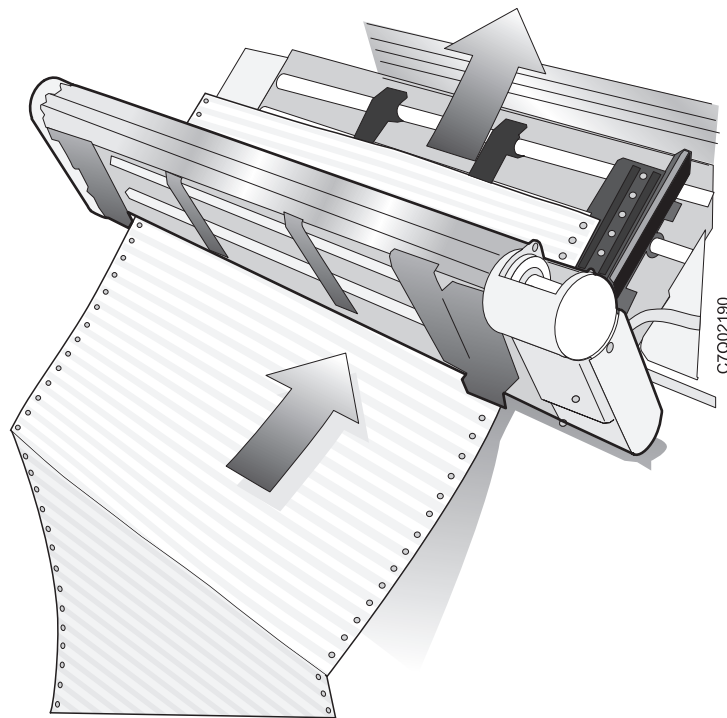

Figure 31. Paper path direction

Removing the optional second tractor

If you need to remove the second optional push tractor, turn the printer off.

1. Disconnect the connector cable and press on the push buttons on either side to disengage the tractor. Then pull the tractor off.

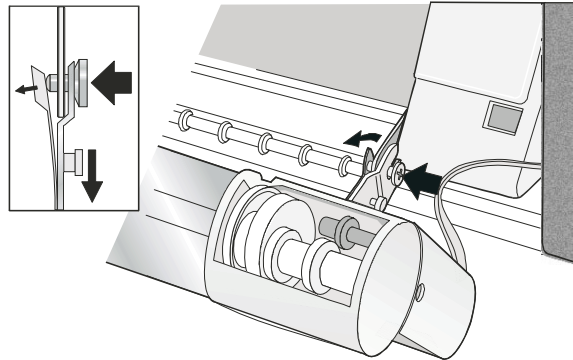

Figure 32. Disconnecting the second tractor.



CAUTION:

<2-53> If the second tractor unit is not installed, make sure the gear protector cover is closed. Do not touch inside the printer or insert any object into the gears.

2. Close the tractor gear protection cover.

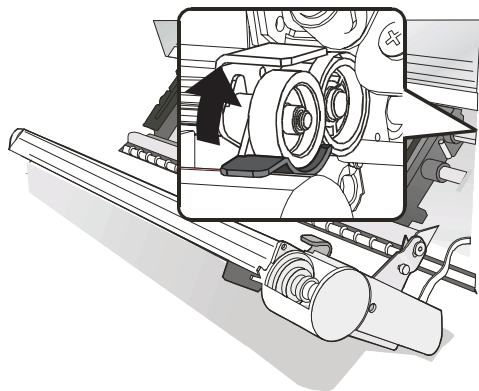

Figure 33. Closing the protection cover.

Attaching the 4247 Printer to your computer

Connect the printer to your host computer using the interface on the Controller Board (supplied in the printer box) you installed in the printer.

There are three types of Controller Boards:

1. Controller Board with a bidirectional IEEE1284 parallel interface, Serial RS232/C 9-pin interface and USB 2.0 interface.
2. Controller Board with a bidirectional IEEE1284 parallel interface and ASCII Ethernet 10/100 BaseT LAN interface.
3. Controller Board with a bi-directional IEEE1284 parallel interface and ASCII-IPDS Ethernet 10/100 BaseT LAN interface.



DANGER

<1-14> Switch off printer power and unplug the printer power cord before connecting or disconnecting a communication port, a teleport, or other attachment connector.

Insert the host computer cable(s) into the back of the printer as shown below:

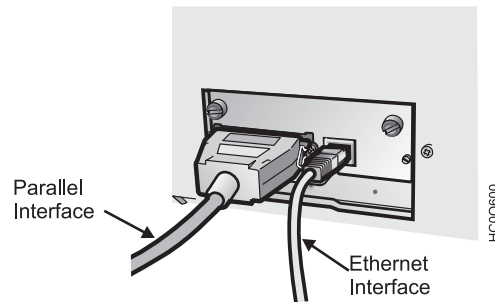

Controller Board with parallel interface and ASCII-IPDS Ethernet 10/100 LAN interface.

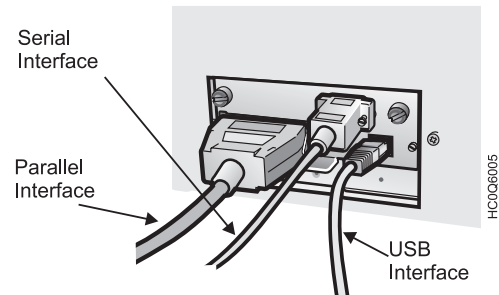

Controller Board with parallel interface, Serial interface, and USB interface.

Completing printer setup

Your 4247 Printer is now ready to use with the forms tractor mounted in the Front Push position and with the configuration parameters set to manufacturing defaults. The exception is that you have selected new defaults for display language.

To select any of the other 4247 paper paths, or to change printer configuration parameters, see:

- Chapter 2, “Understanding the operator panel” for information on operating the printer.
- Chapter 3, “Checking and changing configuration parameter values” for configuration information.
- Chapter 16, “Dual push tractor forms paths” for forms loading procedures.

Software driver selection

See Appendix C, “Printer driver support,” on page 175 for information about selecting printer drivers.

Chapter 2. Understanding the operator panel

Status indicators	27	ENTER function	31
READY	27	RETURN	32
PROCESSING	28	RETURN function	32
ATTENTION	28	PARK/PATH	32
Display panel	28	PARK function	32
Audible alarm	29	PATH function	32
Custom Set In-Use Indicator	29	LINE FEED	33
Function Keys	29	LOAD/EJECT	33
MENU	30	FORM FEED	34
SCROLL/MICRO↑ or SCROLL/MICRO↓	30	SET TOP OF FORM	35
Adjusting forms	31	START	35
Scrolling through categories, parameters, values, and tests	31	STOP	35
ENTER	31	CANCEL PRINT	36
		TEST	36

This chapter describes the function of the operator panel. The operator panel contains 3 status indicators, a 2-line by 24-character display panel, 14 printer function keys, and an audible alarm. Figure 34 illustrates the operator panel and keys for the printer.



Figure 34. 4247 Printer Operator Panel

Status indicators

The following status indicators appear on the operator panel:

- READY
- PROCESSING
- ATTENTION

You can determine printer status by checking these indicators.

READY

If the **READY** indicator is lighted, the printer is *ready* to print. If **READY** is not lighted, the printer is *not ready* to print. The printer can receive data when this indicator is not lighted, but no data can be printed.

The Ready indicator is lighted because of one of the following conditions:

- Successful power-on sequence
- After pressing **START**, if the indicator was off because of one of the following conditions:
 - An error condition (if the error has been corrected)

- An intervention required condition (if the error has been corrected)
- After pressing **STOP**
- After pressing **ENTER** or **START** to run a test in the Operator Print Tests menu
- After a successful partial reset to *ready* after pressing **CANCEL PRINT** to exit the Operator Print Tests

The **READY** indicator is not lighted because of one of the following conditions:

- After pressing **STOP**
- After detection of an intervention required condition
- After detection of a printer error
- After pressing **MENU** to enter the Configuration Menu when no print job is in progress
- After pressing **LOAD/EJECT** to perform an eject to tear off position when Front Push or Rear Push is selected.

PROCESSING

If lighted, the printer is printing or processing data. If blinking, the printer buffer contains data that cannot be printed immediately. If not lighted, there is no data to process and no data in the print buffer.

ATTENTION

If blinking, the printer requires operator intervention (for example, to add forms or to clear a forms jam). The type of intervention needed appears on the display panel. If not lighted, the printer does not require immediate attention.

Display panel

The display panel is a 2-line by 24-character liquid crystal display (LCD) that displays printer status messages, the print test menu, and the configuration menu categories, parameters, and values. Use this display panel and the printer function keys to scroll through and select Configuration Menu items and Operator Print Tests. You can set this display so the messages appear in one of the following languages:

- 000 English (default)
- 001 Deutsch
- 002 Français
- 003 Italiano
- 004 Español
- 005 Nederlands
- 006 Dansk
- 007 Português
- 008 Norsk
- 009 Svenska
- 010 Suomi
- 011 Polski

Audible alarm

If you do not disable the audible alarm, it beeps if any of the following conditions occur:

- Immediate intervention is required
- A printer error condition exists
- The printer receives a command from the host to turn on the alarm
- An invalid key press is attempted
- The **SET TOP OF FORM** key is pressed

To turn a beeping alarm off, press **STOP**. You can disable the audible alarm. See “Alarm control” on page 66 for instructions.

Note: Pressing **SET TOP OF FORM** and some attention conditions sound the alarm, even if it is disabled.

Custom Set In-Use Indicator

This indicator shows the parameter custom set that is currently being used by the printer. The indicator is located in the top right corner of the operator panel. A custom set is a set of configuration values that have been defined at the operator panel and saved under a letter ID. When the custom set identified by this ID is selected from the operator panel, these configuration values are used by the printer.

NOT READY	<X>
-----------	-----

The current custom set in use is displayed in parentheses <X>. Where <X> can be:

- A (Custom Set A in use)
- B (Custom Set B in use)
- C (Custom Set C in use)
- D (Custom Set D in use).
- E (Custom Set E in use)
- F (Custom Set F in use)
- G (Custom Set G in use)
- H (Custom Set H in use).

If a change was made in the configuration menu and not saved in a custom set, then the change is temporary and a **blank < >** is displayed in the parentheses. For more information on Custom Sets, see Chapter 4, “Configuration storage.”

Function Keys

There are 14 keys available on the operator panel for performing printer functions. These keys perform general printer functions (for example, adjusting forms) and are used to scroll through and select items in the Configuration Menu and Operator Print Tests menu.

The following section describes each of the printer function keys on the operator panel.

MENU



Use the Menu function key to enter the Configuration Menu. This function key is valid when the printer is *not ready* or the printer is *ready* and no job is in progress. After you enter the Configuration Menu, paper movement functions are not available.

Press **MENU** to enter the Configuration Menu.

The printer displays:

```
CONFIGURATION MENU
Configuration Storage
```

Note: If a print job is in progress (the printer is printing or the **PROCESSING** indicator is on), the printer displays:

```
009 INVALID KEY PRESS
PRESS STOP FIRST
```

In this case, you can press **STOP** first and then enter the Menu. However, it is not recommended that you change the Configuration Parameter Values while a print job is in progress.

The configuration menu can be locked to prevent an unauthorized user from changing parameter values. When the configuration menu is locked, pressing the **MENU** key only allows recall of Custom Set Values. The Printer Adjustments in the Operator Print Tests Menu are disabled.

If the **MENU** is locked, the printer displays:

```
097 FUNCTION DISABLED
MENU LOCKED
```

For more information on the Menu Lock function, see your system programmer or the *4247 Model X03 Printer Programmer Manual*.

For more information on configuration parameters and values, see “Checking and changing parameter values” on page 38.

SCROLL/MICRO↑ or SCROLL/MICRO↓



Use **SCROLL/MICRO↑** or **SCROLL/MICRO↓** to perform the following functions:

- Adjust forms upward or downward when the printer is *not ready*.
- Scroll through the Configuration Menu categories, parameters, and values.
- Scroll through the Operator Print Tests menu items.

Adjusting forms

Press **SCROLL/MICRO**↑ or **SCROLL/MICRO**↓ to move the form 0.176 mm (1/144 in.) in the direction of the arrow each time you press the key. If you continue to hold down the **SCROLL/MICRO**↑ key, the forms move continuously until you release the key.

When the printer is at the top of the forms and the **SCROLL/MICRO** keys are used, the new forms position is now the top of forms.

Note: If you use these keys when the **PROCESSING** indicator is blinking, the top of form position could become misaligned.

Scrolling through categories, parameters, values, and tests

The scrolling functions are available only when the Configuration Menu or Test Menu is displayed.

Pressing **SCROLL/MICRO**↑ when the Configuration Menu is displayed changes the second line of the display to show the previous configuration category, parameter, or value. Pressing **SCROLL/MICRO**↓ when the Configuration Menu is displayed changes the second line of the display to show the next configuration category, parameter, or value.

Pressing **SCROLL/MICRO**↑ when the Test Menu is displayed changes the second line of the display to show the previous test name. Pressing **SCROLL/MICRO**↓ when the Test Menu is displayed changes the second line of the display to show the next test name.

The scroll keys also enable the selection of numeric values. The list of numeric values starts with the lowest value. When a numeric value is to be entered, use **SCROLL/MICRO**↑ to see the next lower value in the range and **SCROLL/MICRO**↓ to see the next higher value. The values are shown on the second line of the display panel. When the value you wish to select appears, press **ENTER**.

The scrolling functions are also used during some of the Operator Print Tests. See Chapter 17, "Using the Operator Print Tests" for more information.

ENTER

ENTER



ENTER function

The Enter function is available when the Configuration Menu or Operator Print Tests Menu is displayed.

Pressing **ENTER** selects the displayed option.

The Enter function is also used during some of the tests.

RETURN



RETURN function

Pressing **RETURN** in the Configuration Menu returns to the previous level of the menu, unless the printer already displays:

CONFIGURATION MENU Configuration Storage

If Configuration Menu is displayed, the printer exits the menu and becomes *not ready*.

Note: If you have made configuration changes and have not saved them in a Custom Set, the display will prompt you to save the changes. If you are in the Operator Print Tests Menu and a test is not running, pressing **RETURN** will exit the Test Menu and make the printer *not ready*.

PARK/PATH



PARK function

Pressing this key causes the printer to enter the Park function in either the *ready* and *not ready* state. The continuous forms will back up (reverse the process direction of) the forms in the forms path.

If continuous forms are currently in the printer and the top of the form is beyond the print area, press **PARK/PATH**. The forms will be ejected for tearoff and the printer will display:

091 FANFOLD PARK TEAR OUTPUT PRESS PARK
--

If special forms are currently in the printer that cannot be moved backwards (for example, labeled continuous forms), the printer displays:

092 FANFOLD PARK TEAR INPUT PRESS EJECT
--

Perform the action requested on the operator panel display. The printer is then ready for the paper path selection.

PATH function

When no forms are in the current path and the printer is in the *not ready* state, pressing **PARK/PATH** allows the selection of the different forms paths available on the printer. When the desired path is displayed, press **START**. The forms path displayed becomes the active forms path and the printer becomes *ready*. You can also press **LOAD/EJECT** or **FORM FEED** for continuous forms to select the active forms path.

The forms path selected by **PARK/PATH** also becomes the current value for Paper Source in the Printer Setup category. See “Paper Source” on page 101.

LINE FEED



This function is valid only when the printer is *not ready*.

Press **LINE FEED** to cause the printer to advance the forms one print line, based on the current LPI setting. If you hold **LINE FEED** more than four seconds, the forms move continuously until you release the key.

Similar to the forms advance knob on other printer products, the **LINE FEED** key allows coarse vertical movement of forms. This key does not function as an “Index” key, which may be found on other printer products.

Note: If you use this key when the **PROCESSING** indicator is blinking, the top of form position could become misaligned.

LOAD/EJECT



The **LOAD/EJECT** function depends on what active form path you have selected. This section describes the function for each of the paper paths.

The **LOAD/EJECT** key performs the following functions:

- Automatically loads forms
After the forms are loaded under the sensor and onto the tractors at the bottom of the forms device press **LOAD/EJECT** to automatically load the forms to the top of form position.
- Moves forms to the tear-off position
Do not press **STOP** first.
If a Form Feed is done, either by data stream command or by pressing **FORM FEED**, prior to pressing **LOAD/EJECT**, the forms will be positioned for you to tear off the forms at a perforation.

Note:

If pressing **LOAD/EJECT** did not align the forms perforation with the tear bar, check the following:

1. Assure that a Form Feed has been done just prior to pressing **LOAD/EJECT**.
2. Verify that the Tear Position value for the path you are using (Front or Rear) in the Printer Adjustments section of the Configuration Menu has been set correctly. Often this value is the negative of the Paper Load Position value. Adjust the Tear Position to give the best alignment of the forms perforation to the tear bar edge. Each path has its own set of adjustment values. When you change these values, ensure that you are setting the values for the desired path.

If you specify Immediate Eject for Continuous Forms Eject Mode parameter (default value) in the Printer Setup category, press **LOAD/EJECT** to immediately make the printer *not ready*. The printer displays:

```
003 FORMS EJECTED
PRESS LOAD
```

and advances the form so that you can tear off the form at the perforation and remove it from the printer.

If you specify Delayed Eject for the Continuous Forms Eject Mode parameter in the Printer Setup category, press **LOAD/EJECT** to cause the printer to display:

```
093 EJECT PENDING
```

and beep the alarm. When the end of the form is reached, the printer becomes *not ready*, displays:

```
003 FORMS EJECTED
PRESS LOAD
```

and advances the form so that you can tear off the form at the perforation and remove it from the printer.

Pressing the key a second time moves the next form to be printed back to the previous print position and makes the printer *ready*.

Refer to “Continuous Forms Eject Mode” on page 109 for more information on changing Continuous Forms Eject mode.

- Ejects forms for viewing

If a Form Feed is not done prior to pressing **LOAD/EJECT**, the forms will be positioned for you to view them to examine the printing

FORM FEED



This key advances the forms so that the next form is at the top of form position. The Form Feed function is available when the printer is *not ready*.

- If you interrupt a print job by pressing **STOP**, pressing **FORM FEED**, and then pressing **START** (when you are ready to resume the job), the printer continues to print on the next form at the place where printing was interrupted on the previous form.
- If **FORM FEED** is pressed during Front Push or Rear Push load operation, the **FORM FEED** functions as a **LOAD/EJECT** and performs an automatic load.
- The printer does not always have to be *not ready* before pressing **FORM FEED**. See “Form Feed Mode” on page 105 for more information.

SET TOP OF FORM



This should only be used when printing occurred and no Top-of-Forms commands have been passed to the printer (such as Form Feed or Printer initialization).

The Set Top of Form function is available only when the printer is *not ready*, and the paper is loaded to the print line. This key can be used only for the continuous forms paper sources.

Press **SET TOP OF FORM** to set the top of form position for continuous paper sources only. The alarm beeps and the printer displays:

TOP OF FORM SET

while you hold down the **SET TOP OF FORM** key.

If preprinted forms are being used, use Paper Load Positioning (see Chapter 9, "Printer adjustments," on page 115) instead of Top-of-Form.

START



Press **START** to perform the following functions:

- Make the printer *ready* and cause the **READY** message to appear in the operator panel display.
- Exit the Configuration Menu and make the printer *ready*. If a partial reset is required, it is performed to put configuration changes into effect before the printer becomes *ready*.

Note: If you have made configuration changes and have not saved them in a Custom Set, the display will prompt you to save the changes.

- Start the printer printing if no error condition appears on the display and if the computer is sending data to be printed.
- Begin a test from the Operator Print Tests menu.

STOP



If the printer is in a *ready* state, press **STOP** to:

- Make the printer *not ready* and cause the **READY** message to disappear from the operator panel display
- Stop printing as soon as possible without losing print data
- Stop a test if the printer is in test mode
- Stop the printer alarm from beeping
- Allow you to use the other printer function keys
- Cause the printer to display:

NOT READY <X>

(or cause the current test menu to display if the printer is in Operator Print Tests mode)

If an error condition appears on the operator panel display, press **STOP** to:

- Clear the error message from the display
- Stop the printer alarm from beeping.

CANCEL PRINT



When this key is pressed while the printer is active and online, the attachment sends a "cancel request" to the host the printer displays:

059 CANCEL PRINT ACTIVE

For *any attachment option*, the **CANCEL PRINT** button clears all print data and buffers. This function is valid only when the printer is *not ready*.

CANCEL PRINT is also active in Operator Print Tests. If **CANCEL PRINT** is pressed while in the tests, the printer stops any test in process, exits the test mode, performs a partial reset, and becomes *ready*.

TEST



Press **TEST** to enter the Operator Print Tests menu. The Test function is valid only when the printer is *not ready*.

There are several tests available. After you press **TEST**, the printer displays:

OPERATOR PRINT TESTS
Quick Reference

Press **SCROLL/MICRO↑** or **SCROLL/MICRO↓** to display the other available tests.

Refer to Chapter 17, "Using the Operator Print Tests," on page 139 on selecting and running tests.

Chapter 3. Checking and changing configuration parameter values

Printing configuration defaults	37	ASCII Configuration	42
Checking and changing parameter values	38	Printer setup	45
Exiting the Configuration Menu	39	Printer adjustment	46
Exiting using START	39	Power On Reset	46
Exiting using RETURN	39	Display language	47
Locking the Printer Configuration Menu.	40	Vital Product Data	47
Configuration categories	40	Quiet Print	47
Configuration storage	41	Hex Print	48
Attachment	41	Quit From Menu	48
IPDS Configuration.	41		

This chapter gives you brief descriptions and procedures for checking or changing the Configuration Parameter Values. Parameter values are settings the printer recognizes and uses to process print data. These values can be set using the operator panel. They are grouped together into categories of values and are accessed on the operator panel by these categories. These categories are available on the Configuration Menu:

- Configuration Storage
- Attachment
- IPDS Configuration
- ASCII Configuration
- Printer Setup
- Printer Adjustments
- Power On Reset
- Display Language
- Vital Product Data
- Quiet Print
- Hex Print
- Quit From Menu

You can use the Configuration Parameter Values set at the manufacturer, or you can change them. Instructions for checking and changing the Parameter Values for each of these Configuration Categories are described in this section.

Notes:

1. The computer program can override Parameter Values that you select from the operator panel. The values that the computer program *cannot* override are listed in “Configuration categories” on page 40.
2. If a category or parameter that is not valid for your printer application is displayed, you should ignore it; it will not harm the printer or affect its operation.
3. We recommend that you print your custom sets for reference. See “Printer Configuration” in Chapter 17, “Using the Operator Print Tests” for information.

Printing configuration defaults

We recommend that you print your configuration values and save this printout for future reference. See “Printer Configuration” on page 141 for information on printing your printer configuration values.

Checking and changing parameter values

Checking and changing Configuration Parameter Values is done in the Configuration Menu, which is entered with the **MENU** key. The Configuration Menu is divided into three levels:

- Category
- Parameter
- Value

Note: Do not change Parameter Values during a print job; data may be lost.

Press **MENU** to enter the Configuration Menu.

```
CONFIGURATION MENU
Configuration Storage
```

The first category in the Configuration Menu is listed on the second line of the display. Use **SCROLL/MICRO↑** or **SCROLL/MICRO↓** to scroll through the Categories until the category you want is displayed. Press **ENTER** to display the first Parameter in the Category you select. Use **SCROLL/MICRO↑** or **SCROLL/MICRO↓** to scroll through the Parameters until the parameter you want to check or change is displayed. Press **ENTER** to display the current value for the selected Parameter (indicated by an asterisk [*]).

Use **SCROLL/MICRO↑** and **SCROLL/MICRO↓** to scroll through the other available Values until the value you want is displayed. Press **ENTER** to select this new value.

When you change the values and do not save them in a custom set, the printer retains the values until one of the following occurs:

- You power off (O) the printer
- You change the values again

Unless you save the values in a custom set, the values you changed are lost when you power off (O) the printer. The next time you power on (I) the printer, the values you saved previously in the Power-On Custom Set, are the values the printer uses.

See Chapter 4, "Configuration storage" for information about saving and recalling parameter values in custom sets.

Configuration changes do not take effect until the printer completes printing the buffered data (data the printer has in its storage areas).

If you change a parameter (or several parameters) and then decide you do not want to keep your changes, you can return to the previous value settings by selecting Quit from Menu from the Configuration Menu. The printer displays

```
Quit from Menu
Restore Previous Values
```

Press **ENTER** to restore the previous values, exit the Configuration Menu, and make the printer *not ready*. See Chapter 15, "Quit From Menu" for more information about restoring previous values.

Exiting the Configuration Menu

You may quickly exit the Configuration Menu and make the printer *ready* by pressing **START**. You may also exit the menu and make the printer *not ready* using the **RETURN** key. These two methods maintain the changes you have made to the configuration.

Note: If you wish to cancel your changes, you may Quit from the menu; see Chapter 15, “Quit From Menu.”

Exiting using **START**

If you did not make any configuration changes or you stored your changes in a custom set, press **START** and the printer will exit the menu and become *ready*.

If you made configuration changes and did not store them in a custom set, to exit by using **START**, use the following steps:

1. Press **START** from any level of the menu.

The printer displays

```
Press ENTER to Save
Press START to Not Save
```

2. If you do not want to store your changes (they will be lost when the printer is turned off), press **START** again and the printer will exit the menu and become *ready*.
3. To store your changes in a custom set, press **ENTER**.
4. The printer will go to the Value level of the Configuration Storage Category in the menu and display

```
Save Current Values
Custom Set A
```

5. Press **SCROLL/MICRO↑** or **SCROLL/MICRO↓** until the desired custom set name is displayed.
6. Press **ENTER** to store the current parameter values (see Chapter 4, “Configuration storage” for more details).
7. Press **START** again.
The printer will exit the menu and become *ready*.

See “Configuration categories” on page 40 for the parameters you can change and the manufacturing values.

Exiting using **RETURN**

If you did not make any configuration changes or you stored your changes in a custom set, press **RETURN** and the printer will exit the menu and become *not ready*.

If you made configuration changes and did not store them in a custom set, to exit by using **RETURN** use the following steps:

1. If CONFIGURATION MENU is not on the first line of the display, press **RETURN**.
2. Press **RETURN** again.

The printer displays

Press ENTER to Save
Press RETURN to Not Save

3. If you do not want to store your changes (they will be lost when you power off the printer), press **RETURN** again and the printer will exit the menu and become *not ready*.
4. To store your changes in a custom set, press **ENTER**.
5. The printer will go to the Value level of the Configuration Storage Category in the menu and display

Save Current Values
Custom Set A

6. Press **SCROLL/MICRO** or **SCROLL/MICRO** until the desired custom set name is displayed.
7. Press **ENTER** to store the current parameter values (see Chapter 4, "Configuration storage" for more details).
8. Press **RETURN** three times to back out of the menu.
The printer will exit the menu and become *not ready*.

See "Configuration categories" for the parameters you can change and the manufacturing values.

Locking the Printer Configuration Menu

The configuration menu can be locked to prevent an unauthorized user from changing parameter values. When the configuration menu is locked, you can recall saved custom sets (A through H), but cannot change configuration parameter values. The Printer Adjustments in the Operator Print Tests Menu are also disabled.

To lock or unlock the printer configuration:

1. Press **STOP**.
2. Press and hold **TEST**, while pressing **START**. The printer displays

PRESS STOP-->NOT READY

Note: Do not press **STOP**.

3. Press **SET TOP OF FORM**.

Configuration categories

This section lists all the selectable values available and the manufacturing defaults for the parameters in each configuration category.

Configuration storage

Table 1 lists the parameters available for the Configuration Storage Category. Refer to Chapter 4, “Configuration storage” for detailed information on setting these parameters.

Table 1. Configuration Storage Category

Parameters	Values	Default
Save Current Values	Custom Set A-H	N/A
Recall Custom Set	Custom Set A-H	N/A
Power-On Custom Set	Last Used Custom Set A-H	Last Used
Power-On Paper Source	Front Rear Last Used	Front
Recall Factory Defaults	Yes	N/A
Note: Use Recall Factory Defaults to set all the parameters to the manufacturing default values. See “Recall factory defaults” on page 53.		

Attachment

Table 2 lists the parameters available for the Attachment Category. Refer to Chapter 5, “Attachment options,” on page 55 for detailed information on setting these parameters

Table 2. Attachment Category

Parameters	Values	Default
Attachment	Hot Port Switch, Parallel, Serial, USB, LAN ASCII, LAN IPDS	Hot Port Switch

IPDS Configuration

Table 3 lists the parameters available for the IPDS Configuration Category. Parameters that can be overridden by the computer are noted with a dagger (†). Refer to Chapter 6, “IPDS Configuration,” on page 57 for detailed information on setting these parameters

Table 3. IPDS Configuration Category

Parameters	Values	Default
† Characters Per Inch	10 12 15 16.7	10
† Lines Per Inch	6 8	6
† Maximum Print Position	001 to 227	132
† Maximum Page Length	001 to 880	066
† Print Quality	DP Quality DP Text Quality Near Letter Quality	DP Quality

Table 3. IPDS Configuration Category (continued)

Parameters	Values	Default
† Print Language	037 to 1149 Supported Print Languages See Table 13 on page 61.	500 International 5
Emulation Mode	4247 4224 4230	4247
Media Size Priority	Standard Alternate	Alternate
Bar Code Mode	High Low Computer Selected	High
Graphics Mode	High Low Computer Selected	High
Alarm Control	Disabled Enabled	Enabled

ASCII Configuration

Table 4 lists the parameters available for the ASCII Configuration Category. Parameters that can be overridden by the computer are noted with a dagger (†). Refer to Chapter 7, “ASCII Configuration” for detailed information on setting these parameters.

Table 4. ASCII Configuration

Parameters	Values	Default
† Characters Per Inch (CPI)	10 12 15 16.7 17.1 20	10
† Lines Per Inch (LPI)	6 8	6
† Maximum Print Position (MPP)	1 to 272	136
† Maximum Page Length (MPL)	1 to 880	66
† Perforation Skipping	0 to 879	0
† Emulation Mode	4247 2381 Personal Printer 4202 Proprinter III XL Epson-FX	4247
† Print Language	000-1251 Supported Print Languages See Table 13 on page 61.	437 PC (When emulation mode is set to 4247, 4202 III XL, 2381); 0 USA (When emulation mode is set to Epson-FX)

Table 4. ASCII Configuration (continued)

Parameters	Values	Default
† Print Quality (When emulation mode is set to 4247, 4202 III XL, 2381)	DP Quality DP Text Quality Near Letter Quality OCR-A OCR-B	DP Quality
† Print Quality (When emulation is set to Epson-FX)	DP Quality Courier Gothic OCR-A OCR-B	DP Quality
NLQ Typeface (When emulation mode is set to 4247, 4202 III XL, 2381)	Courier Gothic	Courier
Character Set	PC1 PC2 Italics	PC1
Printer Compatibility 3 (Automatic LF on CR)	Disabled Enabled	Disabled
Printer Compatibility 4 (Automatic CR on LF) (When emulation mode is set to 4247, 4202 III XL, or 2381)	Disabled Enabled	Disabled
Printer Compatibility 5 (Form Feed Suppression) (When emulation mode is set to 4247, 4202 III XL, or 2381)	Disabled Enabled	Disabled
Printer Compatibility 6 (Init)	Enabled Disabled	Enabled
Printer Compatibility 7 (Condensed Print) (When emulation mode is set to 4247, 4202 III XL, or 2381)	15 16.7 17.1	17.1
Printer Compatibility 8 (Slashed Zero)	Disabled Enabled	Disabled
Printer Compatibility 9 (20 CPI) (When emulation mode is set to 4247, 4202 III XL, or 2381)	Enabled Disabled	Enabled
Alarm Control	Enabled Disabled	Enabled
Override Host Paper Source	Enabled Disabled	Disabled
Override Host Characters Per Inch	Enabled Disabled	Disabled
Override Host Lines Per Inch	Enabled Disabled	Disabled

Table 4. ASCII Configuration (continued)

Parameters	Values	Default
Override Host Maximum Page Length	Enabled Disabled	Disabled
Parallel Interface Interface Type	PC Parallel 1284 Parallel	PC Parallel
Parallel Interface Input Buffer Size	256 2K 12K 32K 64K 128K	32K
Parallel Interface Select-In Signal (When emulation mode is set to Epson-FX)	Enabled Disabled	Enabled
Parallel Interface AutoFeed XT (When emulation mode is set to Epson-FX)	Disabled Enabled	Disabled
Serial Interface Interface Type	RS-232C	RS-232C
Serial Interface Input Buffer Size	256 2K 12K 32K 64K 128K	32K
Serial Interface Data Bits	7 8	8
Serial Interface Baud Rate	300 600 1200 2400 4800 9600 19200 38400 115200	9600
Serial Interface Parity	None Odd Even Mark Space	None
Serial Interface Pacing Control	DTR XON/XOFF	DTR
Serial Interface Connection Type	Local Remote	Local
LAN Interface* IP Address Assignment	Fixed, DHCP	Fixed
LAN Interface* IP Address	Example: 127.000.000.000	127.000.000.000

Table 4. ASCII Configuration (continued)

Parameters	Values	Default
LAN Interface* Subnet Mask	Example: 255.255.254.000	255.255.254.000
LAN Interface* Default Gateway	Example: 000.000.000.000	000.000.000.000
LAN Interface* Host Name	14 characters (max)	4247_xxxxxx
LAN Interface* Workgroup Name	14 characters (max)	Workgroup
LAN Interface* SMTP Service	Disabled Enabled	Disabled
LAN Interface* Mail Server Address	Example: 000.000.000.000	000.000.000.000
LAN Interface* E-mail Address (Receiver)	48 Characters (max)	Null String
LAN Interface* E-mail Address (Sender)	48 Characters (max)	Null String
*If the LAN ASCII or LAN IPDS attachment is installed.		

Printer setup

Table 5 lists the parameters available for the Printer Setup Category. Parameters that can be overridden by the computer are noted with a dagger (†). Refer to Chapter 8, “Printer setup” for detailed information on setting these parameters.

Table 5. Printer Setup

Parameters	Values	Default
† Paper Source	Front Rear	Front
Front Forms Backup (when front tractor is installed)	Enabled Disabled	Enabled
Rear Forms Backup (when second tractor is installed)	Enabled Disabled	Enabled
Continuous Forms Linking (when second tractor is installed)	Disabled Enabled	Disabled
Form Feed Mode	Not Active in Ready State Active in Ready State	Not Active in Ready State
Automatic Eject	Disabled Enabled	Disabled
Automatic Restore	Disabled Data Timer (10 seconds) Timer (20 seconds) Timer (30 seconds) Timer (40 seconds) Timer (50 seconds)	Disabled
Continuous Forms Eject Mode	Immediate Eject Delayed Eject	Immediate Eject
Bar Code Print Direction	Bidirectional Unidirectional	Bidirectional

Table 5. Printer Setup (continued)

Parameters	Values	Default
Graphics Print Direction	Bidirectional Unidirectional	Bidirectional
Perforation Safety	Disabled Enabled	Disabled
Jam Sensors	Enabled Disabled	Enabled

Printer adjustment

Table 6 lists the parameters available for the Printer Adjustment Category. Refer to Chapter 9, “Printer adjustments” for detailed information on setting these parameters.

Table 6. Printer Adjustment

Parameters	Values	Default
Front AFTA*	-5 to +3 Fixed 1 to 8	0
Front Tear Position	-390 to +30	0
Front Left Margin Alignment	0 to 60	0
Front Paper Load Position	-30 to +360	0
Rear AFTA* (when optional second tractor is installed)	-5 to +3 Fixed 1 to 8	0
Rear Tear Position (when optional second tractor is installed)	-390 to +30	0
Rear Left Margin Alignment (when optional second tractor is installed)	0 to 60	0
Rear Paper Load Position (when optional second tractor is installed)	-30 to +360	0
*Fixed values in 0.5 increments (for example, Fixed 1, Fixed 1.5...Fixed 8)		

Power On Reset

Table 7 lists the parameters available for the Power On Reset. Refer to Chapter 10, “Power-On Reset (POR)” for detailed information on setting these parameters.

Table 7. Power On Reset

Parameters	Values	Default
Power On Reset	Yes	N/A

Display language

Table 8 lists the parameters available for the Display Language Category. Refer to Chapter 11, “Display Language” for detailed information on setting these parameters.

Table 8. Display Language

Parameters	Values	Default
Display Language	000 English 001 Deutsch 002 Français 003 Italiano 004 Español 005 Nederlands 006 Dansk 007 Português 008 Norsk 009 Svenska 010 Suomi 011 Polski	000 English

Vital Product Data

Table 9 lists the parameters available for the Vital Product Data Category. Refer to Chapter 12, “Vital Product Data” for detailed information on setting these parameters.

Table 9. Vital Product Data Category

Parameters	Values	Default
Serial Number	xxxxxxx	0000000
Device Specific Information	xxxxxxxxxxxxxxxxxx	0000000000000000

Quiet Print

Table 10 lists the parameters available for the Quiet Print category. Refer to Chapter 13, “Quiet Print,” on page 129 for detailed information on setting these parameters.

Table 10. Quiet Print Category

Parameters	Values	Default
Quiet Print	No Yes	No

Hex Print

Table 11 lists the parameters available for the Hex Print category. Refer to Chapter 14, "Hex Print," on page 131 for detailed information on setting these parameters.

Table 11. Hex Print Category

Parameters	Values	Default
Hex Print	No Yes	No

Quit From Menu

Table 12 lists the parameters available for the Quit From Menu Category. Refer to Chapter 15, "Quit From Menu" for detailed information on setting these parameters.

Table 12. Quit From Menu Category

Parameters	Values	Default
Quit From Menu	Restore Previous Values	N/A

Chapter 4. Configuration storage

Custom sets	49	Power-On Custom Set	51
Non-custom set	49	Power-On Paper Source	52
Save Current Values in Custom Sets	50	Recall factory defaults	53
Recall Custom Set values	51	Printing custom sets	54

This chapter describes the procedures for setting configuration storage values. It explains the two types of configuration storage (custom and non-custom) and describes how to create and save them in printer memory.

Custom sets

There are eight custom sets (A, B, C, D, E, F, G, and H) that you can create and retain. Custom sets contain values for the parameters listed in Chapter 3, “Checking and changing configuration parameter values,” on page 37:.

Non-custom set

The non-custom set contains parameter values that stay the same, no matter which custom set you are using. The following parameter values are saved in this part of printer memory:

- Configuration Storage
 - All
- Attachment
- Parallel Interface
 - Printer Compatibility 6 (Init)
 - Interface Type
 - Input Buffer Size
 - Select-In Signal
 - AutoFeed-XT
- Serial Interface
 - All, except Interface Type, Input Buffer Size, Data Bits, Baud Rate, Parity, Pacing Control, and Connection Type
- LAN Interface
 - All
- Printer Setup
 - Paper Source
- Power On Reset
 - Yes
- Vital Product Data
- Quit From Menu

Changes to these values are saved at the same time you save values that go into custom sets. If you save a change made to one of these non-custom set parameter values, the new value will be in effect no matter which custom set you recall.

Save Current Values in Custom Sets

The Save Current Values stores the current values of the configuration parameters to one of the eight custom sets (described in “Custom sets” on page 49).

You can save the current values to:

- Custom Set A
- Custom Set B
- Custom Set C
- Custom Set D
- Custom Set E
- Custom Set F
- Custom Set G
- Custom Set H

All of the custom sets are initially set to the manufacturing default values.

To save current configuration values in a custom set, follow these steps:

1. Press **MENU**.
2. Press **SCROLL/MICRO↑** or **SCROLL/MICRO↓** until the printer displays

```
CONFIGURATION MENU
Configuration Storage
```

3. Press **ENTER**.
4. Press **SCROLL/MICRO↑** or **SCROLL/MICRO↓** until the printer displays

```
Configuration Storage
Save Current Values
```

5. Press **ENTER** to display the current value.
6. Press **SCROLL/MICRO↑** or **SCROLL/MICRO↓** until the desired custom set value is displayed.

Note: If you have previously created a custom set definition for that letter, that information will be replaced with the new information when you press **ENTER**.

7. Press **ENTER**.
The printer displays a message similar to

```
Save Current Values
Custom Set A Saved
```

8. Use **START** or **RETURN** to exit the Menu. See “Exiting the Configuration Menu” on page 39. The display will be updated to show the new custom set that is in use. See “Custom Set In-Use Indicator” on page 29.

Recall Custom Set values

The Recall Custom Set values recalls configuration parameters previously stored. (Custom sets are described in “Custom sets” on page 49.)

You can recall current values from:

- Custom Set A
- Custom Set B
- Custom Set C
- Custom Set D
- Custom Set E
- Custom Set F
- Custom Set G
- Custom Set H

Note: When a new custom set is recalled, a partial reset is automatically performed when exiting from the configuration menu if the value of at least one of the parameters that requires a partial reset has been changed. Buffered data will be lost.

To recall custom set values, follow these steps:

1. Press **MENU**.
2. Press **SCROLL/MICRO↑** or **SCROLL/MICRO↓** until the printer displays

```
CONFIGURATION MENU
Configuration Storage
```

3. Press **ENTER**.
4. Press **SCROLL/MICRO↑** or **SCROLL/MICRO↓** until the printer displays

```
Configuration Storage
Recall Custom Set Values
```

5. Press **ENTER** to display the current value.
6. Press **SCROLL/MICRO↑** or **SCROLL/MICRO↓** until the desired custom set value is displayed.
7. Press **ENTER**. The printer displays a message similar to

```
Recall Custom Set
Custom Set A Recalled
```

8. Use **START** or **RETURN** to exit the Menu. See “Exiting the Configuration Menu” on page 39.

Power-On Custom Set

The Power-On Custom Set is the custom set that is used when the printer is turned on. The Last Used value means the custom set used before the printer was powered off is to be used as the power-on custom set.

You can change the Power-On Custom Set to:

- Last Used (Default)
- Custom Set A
- Custom Set B
- Custom Set C

- Custom Set D
- Custom Set E
- Custom Set F
- Custom Set G
- Custom Set H

To change or check the power-on custom set, follow these steps:

1. Press **MENU**.
2. Press **SCROLL/MICRO** or **SCROLL/MICRO** until the printer displays

```
CONFIGURATION MENU
Configuration Storage
```

3. Press **ENTER**.
4. Press **SCROLL/MICRO** or **SCROLL/MICRO** until the printer displays

```
Configuration Storage
Power-On Custom Set
```

5. Press **ENTER** to display the current value.
6. Press **SCROLL/MICRO** or **SCROLL/MICRO** until the desired custom set for the new power-on custom set is displayed.
7. Press **ENTER**.
An asterisk (*) will be displayed in front of the selected custom set.
8. Use **START** or **RETURN** to exit the Menu. See “Exiting the Configuration Menu” on page 39.

Power-On Paper Source

The Power-On Paper Source allows you to select which paper source is to be used when the printer is turned on. The Last Used value means that the paper source used before the printer was powered off is to be used as the power-on paper source.

You can change the Power-On Paper Source to:

- Front (Default)
- Rear
- Last Used

Selecting Last Used causes the Paper Source parameter (in the Printer Setup menu) to be updated whenever the data stream selects a paper source. If the data stream attempts to select the operator panel setting for power-on paper source, the most recently selected paper source will be used instead.

To change or check the power-on paper source, follow these steps:

1. Press **MENU**.
2. Press **SCROLL/MICRO** or **SCROLL/MICRO** until the printer displays

```
CONFIGURATION MENU
Configuration Storage
```

3. Press **ENTER**.
4. Press **SCROLL/MICRO** or **SCROLL/MICRO** until the printer displays

```
Configuration Storage
Power-On Paper Source
```

5. Press **ENTER** to display the current value.
6. Press **SCROLL/MICRO↑** or **SCROLL/MICRO↓** until the desired Power-on Paper Source value is displayed.
7. Press **ENTER**.
An asterisk (*) will be displayed in front of the selected paper source.
8. Use **START** or **RETURN** to exit the Menu. See “Exiting the Configuration Menu” on page 39.

Recall factory defaults

This function sets all parameter values to the original manufacturing default values, except Vital Product Data and Printer Address (Twinax attachment). These settings can only be changed through their own menu selection.

The printer is shipped with all of the custom sets set to manufacturing default values and custom set A as the power-on custom set. The Recall Factory Defaults function does not affect the values saved in custom sets.

Note: When factory defaults are recalled, a partial reset is automatically performed when exiting from the configuration menu if the value of at least one of the parameters that requires a partial reset has been changed. Buffered data will be lost.

To recall the factory defaults, follow these steps:

1. Press **MENU**.
2. Press **SCROLL/MICRO↑** or **SCROLL/MICRO↓** until the printer displays

```
CONFIGURATION MENU
Configuration Storage
```

3. Press **ENTER**.
4. Press **SCROLL/MICRO↑** or **SCROLL/MICRO↓** until the printer displays

```
Configuration Storage
Recall Factory Defaults
```

5. Press **ENTER**.
The printer displays

```
Recall Factory Defaults
Yes
```

6. Press **ENTER**.
The printer displays

```
Recall Factory Defaults
Factory Defaults Recalled
```

7. Use **START** or **RETURN** to exit the Menu. See “Exiting the Configuration Menu” on page 39.

Printing custom sets

Use this function to create a printout of the eight custom set values.

On the first page of the printout, each custom set is identified as either In Use or as Factory Defaults.

In Use At least one value in the custom set is different from the factory default value. A flag (****) is printed after each parameter value that is different from the factory default.

Factory Defaults

A custom set that is identical to one of the factory defaults.

If a custom set is identical to the factory defaults, it will be identified as Factory Defaults. If the only change from factory defaults is a non-custom set parameter value (a value that stays the same no matter which custom set you are using), only the first custom set will be identified as In Use. The other custom sets will be shown as factory defaults.

To print the custom sets:

1. Press **STOP** to make the printer *not ready*.
2. Press **TEST**.
3. Press **SCROLL/MICRO↑** or **SCROLL/MICRO↓** until the printer displays

OPERATOR PRINT TESTS Print Custom Sets

4. Use **ENTER** or **START** to begin the test. The printout will list all the custom sets.
The Ready indicator is lighted, and the Print Test prints. The printout is complete when the Ready indicator is no longer lighted.
5. Press **Cancel Print** to make the printer *ready*, or **RETURN** to make the printer *not ready*.

Chapter 5. Attachment options

This chapter describes the procedures for setting your printer attachment. Your printer is capable of attaching individually through the following attachment interface options:

- Bidirectional IEEE 1284 Parallel
- Serial RS232/C 9-Pin
- USB 2.0
- ASCII Ethernet 10/100 BaseT LAN
- ASCII-IPDS Ethernet 10/100 BaseT LAN

The attachments you have depend on what you requested at the time you placed your order for the printer. To change or check the attachment selection, follow these steps:

1. Press **MENU**.
2. Press **SCROLL/MICRO↑** or **SCROLL/MICRO↓** (down) until the printer displays

```
CONFIGURATION MENU
Attachment
```

3. Press **ENTER**.

The printer displays

```
Attachment
* xxxxxx
```

Where *xxxxxx* (depending on your currently selected attachment) can be Hot Port Switch, Parallel, Serial, USB, LAN ASCII, or LAN IPDS.

4. Press **SCROLL/MICRO↑** or **SCROLL/MICRO↓** until the desired value is displayed.
5. Press **ENTER**.
An asterisk (*) will be displayed in front of the selected value.
6. Press **START** or **RETURN** to exit the Menu. See “Exiting the Configuration Menu” on page 39.

Chapter 6. IPDS Configuration

Characters Per Inch (CPI)	57	Emulation mode	62
Lines Per Inch (LPI)	58	Media Size Priority	63
Maximum Print Position (MPP)	58	Bar Code Mode	64
Maximum Page Length (MPL)	59	Graphics Mode	65
Print Quality	60	Alarm control	66
Print language	61		

This section describes how to check and change IPDS configuration parameters for your 4247 printer. The chapter is divided into sections according to parameter. Refer to this partial table of contents for parameter and page listings.

Characters Per Inch (CPI)

You can set the Characters Per Inch (CPI) to any of the following values:

- 10 (Default)
- 12
- 15
- 16.7

Notes:

1. It is possible to specify a CPI value that causes the page width (maximum print position) to exceed the maximum physical page width. If this occurs, the printer automatically changes the maximum print position to the highest valid value for the new CPI setting. See “Maximum Print Position (MPP)” on page 58 for more information.
2. This parameter can be overridden by the computer.
3. Only 10 CPI is valid when either OCR-A or OCR-B is selected as a print language.

To change or check the CPI value, follow these steps:

1. Press **MENU**.
2. Press **SCROLL/MICRO↑** or **SCROLL/MICRO↓** until the printer displays

```
CONFIGURATION MENU
IPDS Configuration
```

3. Press **ENTER**.
The printer displays

```
IPDS Configuration
Characters Per Inch
```

4. Press **ENTER** to display the current value.
5. Press **SCROLL/MICRO↑** or **SCROLL/MICRO↓** until the desired value for CPI is displayed.
6. Press **ENTER**.
An asterisk (*) will be displayed in front of the selected value.
7. Press **START** or **RETURN** to exit the Menu. See “Exiting the Configuration Menu” on page 39.

Lines Per Inch (LPI)

You can set the lines per inch (LPI) for the printer to either of the following values:

- 6 (Default)
- 8

Note: This parameter can be overridden by the computer.

To change or check the LPI, follow these steps:

1. Press **MENU**.
2. Press **SCROLL/MICRO↑** or **SCROLL/MICRO↓** until the printer displays

CONFIGURATION MENU IPDS Configuration
--

3. Press **ENTER**.
4. Press **SCROLL/MICRO↑** or **SCROLL/MICRO↓** until the printer displays

IPDS Configuration Lines Per Inch

5. Press **ENTER** to display the current value.
6. Press **SCROLL/MICRO↑** or **SCROLL/MICRO↓** until the desired value for LPI is displayed.
7. Press **ENTER**.
An asterisk (*) will be displayed in front of the selected value.
8. Press **START** or **RETURN** to exit the Menu. See “Exiting the Configuration Menu” on page 39.

Maximum Print Position (MPP)

The maximum print position (MPP) equals the number of characters the printer prints on a line. The default value is 132.

The CPI setting you choose directly influences the MPP value you select. The MPP and CPI settings determine the length of the print line. The maximum line length for the printer is 345.44 mm (13.6 in.).

The CPI setting and the line length determine the MPP. Multiply the CPI by the line length to determine the appropriate MPP:

$$\text{MPP} = \text{CPI} \times \text{line length (in inches)}$$

If your CPI is:	MPP cannot be greater than:
10	136
12	163
15	204
16.7	227

Notes:

1. Setting the MPP larger than the paper width can result in lost data because of printing on the platen and may damage the platen and the printhead.
2. This parameter can be overridden by the computer.

To change or check the MPP value, follow these steps:

1. Press **MENU**.
2. Press **SCROLL/MICRO↑** or **SCROLL/MICRO↓** until the printer displays

```
CONFIGURATION MENU
IPDS Configuration
```

3. Press **ENTER**.
4. Press **SCROLL/MICRO↑** or **SCROLL/MICRO↓** until the printer displays

```
IPDS Configuration
Maximum Print Position
```

5. Press **ENTER** to display the current value.
6. Press **SCROLL/MICRO↑** or **SCROLL/MICRO↓** until the desired value for MPP is displayed.
7. Press **ENTER**.
An asterisk (*) will be displayed in front of the selected value.
8. Press **START** or **RETURN** to exit the Menu. See “Exiting the Configuration Menu” on page 39.

Maximum Page Length (MPL)

You can set the maximum page length (MPL) for the printer from 1–660 lines for 6 LPI and 1–880 lines for 8 LPI. The default value is 66 lines.

MPL equals the number of print lines the printer can print on a page. MPL is the page length stated in number of print lines.

See the following example to determine how to calculate the MPL.

The LPI and the page length determine the MPL. Multiply the lines per inch by the page length to determine the appropriate MPL:

$$\text{MPL} = \text{LPI} \times \text{page length (in inches)}$$

For example, if LPI=6 and page length=254 mm (10 in.), then

$$\text{MPL} = 6 \times 10$$

$$\text{MPL} = 60$$

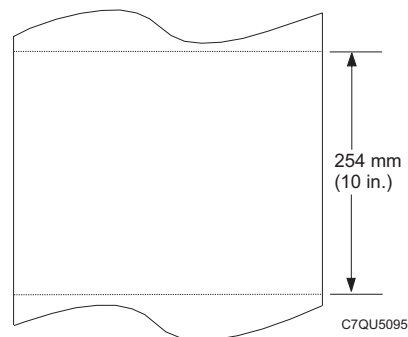

Note: This parameter can be overridden by the computer.

To change or check the MPL, follow these steps:

1. Press **MENU**.
2. Press **SCROLL/MICRO↑** or **SCROLL/MICRO↓** until the printer displays

```
CONFIGURATION MENU
IPDS Configuration
```

3. Press **ENTER**.
4. Press **SCROLL/MICRO↑** or **SCROLL/MICRO↓** until the printer displays

```
IPDS Configuration
Maximum Page Length
```

5. Press **ENTER** to display the current value.
6. Press **SCROLL/MICRO↑** or **SCROLL/MICRO↓** until the desired value for MPL is displayed.
7. Press **ENTER**.
An asterisk (*) will be displayed in front of the selected value.
8. Press **START** or **RETURN** to exit the Menu. See “Exiting the Configuration Menu” on page 39.

Print Quality

You can set the Print Quality for the printer to any of the following values:

- **DP (Data Processing) Quality** (Default)
- **DP Text Quality**
- **Near Letter Quality (NLQ)**.

Notes:

1. This parameter can be overridden by the computer.
2. Only Near Letter Quality is valid when either OCR-A or OCR-B is selected as the print language.

To change or check the Print Quality, follow these steps:

1. Press **MENU**.
2. Press **SCROLL/MICRO↑** or **SCROLL/MICRO↓** until the printer displays

```
CONFIGURATION MENU
IPDS Configuration
```

3. Press **ENTER**.
4. Press **SCROLL/MICRO↑** or **SCROLL/MICRO↓** until the printer displays

```
IPDS Configuration
Print Quality
```

5. Press **ENTER** to display the current value.
6. Press **SCROLL/MICRO↑** or **SCROLL/MICRO↓** until the desired value for Print Quality is displayed.
7. Press **ENTER**.
An asterisk (*) will be displayed in front of the selected value.
8. Press **START** or **RETURN** to exit the Menu. See “Exiting the Configuration Menu” on page 39.

Print language

The following print languages are available on the printer when attachment is set to LAN IPDS. The default is marked with an asterisk (*). You can select any print language that is available for your printer.

Determine the value for the language setting you want from the following table:

Table 13. Supported Print Languages

Code Page	Language
37	USA/Canada
260	Canadian French
273	Austrian/German
274	Belgian Old
275	Brazilian
277	Danish/Norwegian
278	Finnish/Swedish
280	Italian
281	Japanese English
282	Portuguese
284	Spanish/Spanish Speaking
285	English (UK)
290	Japanese Katakana
297	French/French Azerty
420	Arabic
423	Greek (Old)
424	Hebrew Bulletin
500 (*)	International 5/Swiss/Belgian
813	Greek/Latin (ISO 8859-7) + euro
833	Korean
838	Thai
870	Latin 2/ROECE
871	Icelandic
875	Greek (New) + euro
880	Cyrillic
890	Yugoslav (Old)
892	OCR-A
893	OCR-B
924	Latin 9 (ISO 8859) + euro
1025	Cyrillic Multilingual
1026	Latin-5 Turkey
1097	Farsi
1112	Baltic Multilingual
1122	Estonian

Table 13. Supported Print Languages (continued)

Code Page	Language
1140	USA/Canada + euro
1141	Austrian/German + euro
1142	Danish/Norwegian + euro
1143	Finnish/Swedish + euro
1144	Italian + euro
1145	Spanish/Spanish Speaking + euro
1146	English (UK) + euro
1147	French + euro
1148	International 5/Belgian New + euro
1149	Icelandic + euro

Notes:

1. The printer performs a partial reset to put any change to this parameter value into effect when you exit the Configuration Menu with **START** or **RETURN**. Buffered data will be lost.
2. This parameter can be overridden by the computer.
3. When either OCR-A or OCR-B is selected, the selectable options for CPI and print quality become fixed at 10 CPI and Near Letter Quality, respectively.

To change or check the print language value, follow these steps:

1. Press **MENU**.
2. Press **SCROLL/MICRO↑** or **SCROLL/MICRO↓** until the printer displays

```
CONFIGURATION MENU
IPDS Configuration
```

3. Press **ENTER**.
4. Press **SCROLL/MICRO↑** or **SCROLL/MICRO↓** until the printer displays

```
IPDS Configuration
Print Language
```

5. Press **ENTER** to display the current value.
6. Press **SCROLL/MICRO↑** or **SCROLL/MICRO↓** until the desired language value is displayed.
7. Press **ENTER**.
An asterisk (*) will be displayed in front of the selected value.
8. Press **START** or **RETURN** to exit the Menu. See “Exiting the Configuration Menu” on page 39.

Emulation mode

You can set Emulation Mode to the following values:

- 4247 (Default)
- 4224
- 4230

Notes:

1. The printer performs a partial reset to put any change to this parameter value into effect when you exit the Configuration Menu with **START** or **RETURN**. Buffered data will be lost.
2. When changing the value of the Emulation Mode, verify the Data Stream and the Printer Address you have set.

To change or check the emulation mode, follow these steps:

1. Press **MENU**.
2. Press **SCROLL/MICRO↑** or **SCROLL/MICRO↓** until the printer displays

```
CONFIGURATION MENU
IPDS Configuration
```

3. Press **ENTER**.
4. Press **SCROLL/MICRO↑** or **SCROLL/MICRO↓** until the printer displays

```
IPDS Configuration
Emulation Mode
```

5. Press **ENTER** to display the current value.
6. Press **SCROLL/MICRO↑** or **SCROLL/MICRO↓** until the desired value for Emulation Mode is displayed.
7. Press **ENTER**.
An asterisk (*) will be displayed in front of the selected value.
8. Press **START** or **RETURN** to exit the Menu. See “Exiting the Configuration Menu” on page 39.

Media Size Priority

This parameter is available only if the IPDS feature is installed, and the IPDS data stream is selected. It affects the use of the XOH Set Media Size (SMS) order. This order may be used in the IPDS data stream to set the page size. The Media Size Priority setting specifies whether XOH-SMS orders take precedence over the operator panel settings for maximum print position (MPP) and maximum page length (MPL).

The following values will be displayed in the menu:

Standard	The smaller page size values have priority. The page size will be the intersection (smaller values) of the operator panel settings and the XOH-SMS X and Y values.
Alternate (default)	The XOH-SMS order values have priority. If an XOH-SMS order is present, its values will be used to define the page size instead of the operator panel settings.

The media size is defined by the MPP and MPL parameters.

To change or check the Media Size Priority, follow these steps:

1. Press **MENU**.
2. Press **SCROLL/MICRO↑** or **SCROLL/MICRO↓** until the printer displays

```
CONFIGURATION MENU
IPDS Configuration
```

3. Press **ENTER**.
4. Press **SCROLL/MICRO↑** or **SCROLL/MICRO↓** until the printer displays

```
IPDS Configuration
Media Size Priority
```

5. Press **ENTER** to display the current value.
6. Press **SCROLL/MICRO↑** or **SCROLL/MICRO↓** until the desired value for media size priority is displayed.
7. Press **ENTER**.
An asterisk (*) will be displayed in front of the selected value.
8. Press **START** or **RETURN** to exit the Menu. See “Exiting the Configuration Menu” on page 39.

Bar Code Mode

This parameter is valid only if the IPDS feature is installed and the IPDS data stream is selected. Changing the value of this parameter can affect throughput in some printing environments.

You can set the Bar Code Mode to any of the following values:

High (Default)	High Contrast Bar Codes
Low	Low Contrast Bar Codes
Computer Selected	Contrast as specified by the IPDS data stream

Note: The printer performs a partial reset to put any change to this parameter value into effect when you exit the Configuration Menu with **START** or **RETURN**. Buffered data will be lost.

To change or check the bar code mode, follow these steps:

1. Press **MENU**.
2. Press **SCROLL/MICRO↑** or **SCROLL/MICRO↓** until the printer displays

```
CONFIGURATION MENU
IPDS Configuration
```

3. Press **ENTER**.
4. Press **SCROLL/MICRO↑** or **SCROLL/MICRO↓** until the printer displays

```
IPDS Configuration
Bar Code Mode
```

5. Press **ENTER** to display the current value.
6. Press **SCROLL/MICRO↑** or **SCROLL/MICRO↓** until the desired value for bar code mode is displayed
7. Press **ENTER**.
An asterisk (*) will be displayed in front of the selected value.

8. Press **START** or **RETURN** to exit the Menu. See “Exiting the Configuration Menu” on page 39.

Graphics Mode

This parameter is available only if the IPDS feature is installed and the IPDS data stream is selected. Changing the value of this parameter can affect throughput in some printing environments.

You can set the Graphics Mode to any of the following values:

High (Default)	High Density Graphics
Low	Low Density Graphics
Computer Selected	Density as specified by the IPDS data stream

Note: The printer performs a partial reset to put any change to this parameter value into effect when you exit the Configuration Menu with **START** or **RETURN**. Buffered data will be lost.

To change or check the graphics mode, follow these steps:

1. Press **MENU**.
2. Press **SCROLL/MICRO↑** or **SCROLL/MICRO↓** until the printer displays

```
CONFIGURATION MENU
IPDS Configuration
```

3. Press **ENTER**.
4. Press **SCROLL/MICRO↑** or **SCROLL/MICRO↓** until the printer displays

```
IPDS Configuration
Graphics Mode
```

5. Press **ENTER** to display the current value.
6. Press **SCROLL/MICRO↑** or **SCROLL/MICRO↓** until the desired value for graphics mode is displayed.
7. Press **ENTER**.
An asterisk (*) will be displayed in front of the selected value.
8. Press **START** or **RETURN** to exit the Menu. See “Exiting the Configuration Menu” on page 39.

Alarm control

You can set the audible printer alarm to either of the following values:

- **Enabled** (Default)
- **Disabled**

Note: Pressing **SET TOP OF FORM** and some unit check conditions sound the alarm, even if it is disabled.

To change or check the alarm control, follow these steps:

1. Press **MENU**.
2. Press **SCROLL/MICRO↑** or **SCROLL/MICRO↓** until the printer displays

```
CONFIGURATION MENU
IPDS Configuration
```

3. Press **ENTER**.
4. Press **SCROLL/MICRO↑** or **SCROLL/MICRO↓** until the printer displays

```
IPDS Configuration
Alarm Control
```

5. Press **ENTER** to display the current value.
6. Press **SCROLL/MICRO↑** or **SCROLL/MICRO↓** until the desired value for alarm control is displayed.
7. Press **ENTER**.
An asterisk (*) will be displayed in front of the selected value.
8. Press **START** or **RETURN** to exit the Menu. See “Exiting the Configuration Menu” on page 39.

Chapter 7. ASCII Configuration

Characters Per Inch (CPI)	67	Parallel interface	86
Lines Per Inch (LPI)	68	Interface type	86
Maximum Print Position (MPP)	69	Input Buffer Size	86
Maximum Page Length (MPL)	70	Select-In	87
Perforation skipping	71	AutoFeed-XT	88
Emulation Mode	71	Serial interface	88
Print language	72	Interface type	88
Print quality	74	Input Buffer Size	89
NLQ typeface	75	Data Bits	90
Character set	75	Baud Rate	90
Printer Compatibility 3 (automatic line feed on carriage return)	76	Parity	91
Printer Compatibility 4 (automatic carriage return on line feed)	76	Pacing Control	92
Printer Compatibility 5 (form feed suppression)	77	Connection Type	92
Printer Compatibility 6 (Init)	78	LAN Interface	93
Printer Compatibility 7 (condensed print)	79	IP Address Assignment	93
Printer Compatibility 8 (slashed zero)	79	IP Address	93
Printer Compatibility 9 (20 CPI)	80	Subnet Mask	94
Alarm control	81	Default Gateway	95
Override Host parameters	82	Host Name	95
Paper source	82	Workgroup Name	96
Characters Per Inch (CPI)	83	SMTP Service	97
Lines Per Inch (LPI)	84	Mail Server Address	97
Maximum Page Length	85	E-Mail Address (Receiver)	98
		E-Mail Address (Sender)	99

This chapter describes the procedures for checking and changing ASCII configuration parameters for your 4247 printer. The chapter is divided into sections according to parameter. Refer to the partial table of contents at the beginning of this chapter for parameter and page listings.

Characters Per Inch (CPI)

You can set the Characters Per Inch (CPI) to any of the following values:

- 10 (Default)
- 12
- 15
- 16.7
- 17.1
- 20

Notes:

1. It is possible to specify a CPI value that causes the page width (maximum print position) to exceed the maximum physical page width. If this occurs, the printer automatically changes the maximum print position to the highest valid value for the new CPI setting. See “Maximum Print Position (MPP)” on page 69 for more information.
2. This parameter can be overridden by the computer.
3. Only 10 CPI is valid when either OCR-A or OCR-B is selected as a print language.

To change or check the CPI value, follow these steps:

1. Press **MENU**.
2. Press **SCROLL/MICRO↑** or **SCROLL/MICRO↓** until the printer displays

```
CONFIGURATION MENU
ASCII Configuration
```

3. Press **ENTER**.
The printer displays

```
ASCII Configuration
Characters Per Inch
```

4. Press **ENTER** to display the current value.
5. Press **SCROLL/MICRO↑** or **SCROLL/MICRO↓** until the desired value for CPI is displayed.
6. Press **ENTER**.
An asterisk (*) will be displayed in front of the selected value.
7. Press **START** or **RETURN** to exit the Menu. See “Exiting the Configuration Menu” on page 39.

Lines Per Inch (LPI)

You can set the lines per inch (LPI) for the printer to either of the following values:

- 6 (Default)
- 8

Note: This parameter can be overridden by the computer.

To change or check the LPI, follow these steps:

1. Press **MENU**.
2. Press **SCROLL/MICRO↑** or **SCROLL/MICRO↓** until the printer displays

```
CONFIGURATION MENU
ASCII Configuration
```

3. Press **ENTER**.
4. Press **SCROLL/MICRO↑** or **SCROLL/MICRO↓** until the printer displays

```
ASCII Configuration
Lines Per Inch
```

5. Press **ENTER** to display the current value.
6. Press **SCROLL/MICRO↑** or **SCROLL/MICRO↓** until the desired value for LPI is displayed.
7. Press **ENTER**.
An asterisk (*) will be displayed in front of the selected value.
8. Press **START** or **RETURN** to exit the Menu. See “Exiting the Configuration Menu” on page 39.

Maximum Print Position (MPP)

The maximum print position (MPP) equals the number of characters the printer prints on a line. The default value is 136.

The CPI setting you choose directly influences the MPP value you select. The MPP and CPI settings determine the length of the print line. The maximum line length for the printer is 345.44 mm (13.6 in.).

The CPI setting and the line length determine the MPP. Multiply the CPI by the line length to determine the appropriate MPP:

$$\text{MPP} = \text{CPI} \times \text{line length (in inches)}$$

If your CPI is:	MPP cannot be greater than:
10	136
12	163
15	204
16.7	227
17.1	233
20	272

Notes:

1. Setting the MPP larger than the paper width can result in lost data because of printing on the platen and may damage the platen and the printhead.
2. This parameter can be overridden by the computer.

To change or check the MPP value, follow these steps:

1. Press **MENU**.
2. Press **SCROLL/MICRO↑** or **SCROLL/MICRO↓** until the printer displays

```
CONFIGURATION MENU
ASCII Configuration
```

3. Press **ENTER**.
4. Press **SCROLL/MICRO↑** or **SCROLL/MICRO↓** until the printer displays

```
ASCII Configuration
Maximum Print Position
```

5. Press **ENTER** to display the current value.
6. Press **SCROLL/MICRO↑** or **SCROLL/MICRO↓** until the desired value for MPP is displayed.
7. Press **ENTER**.
An asterisk (*) will be displayed in front of the selected value.
8. Press **START** or **RETURN** to exit the Menu. See "Exiting the Configuration Menu" on page 39.

Maximum Page Length (MPL)

You can set the maximum page length (MPL) for the printer from 1–880 lines, depending on the LPI setting. The default value is 66 lines.

MPL equals the number of print lines the printer can print on a page. MPL is the page length stated in number of print lines.

See the following example to determine how to calculate the MPL.

The LPI and the page length determine the MPL. Multiply the lines per inch by the page length to determine the appropriate MPL:

$$\text{MPL} = \text{LPI} \times \text{page length (in inches)}$$

For example, if LPI=6 and page length=254 mm (10 in.), then

$$\text{MPL} = 6 \times 10$$

$$\text{MPL} = 60$$

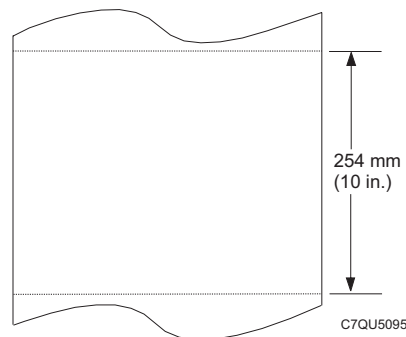

Note: This parameter can be overridden by the computer.

To change or check the MPL, follow these steps:

1. Press **MENU**.
2. Press **SCROLL/MICRO↑** or **SCROLL/MICRO↓** until the printer displays

```
CONFIGURATION MENU
ASCII Configuration
```

3. Press **ENTER**.
4. Press **SCROLL/MICRO↑** or **SCROLL/MICRO↓** until the printer displays

```
ASCII Configuration
Maximum Page Length
```

5. Press **ENTER** to display the current value.
6. Press **SCROLL/MICRO↑** or **SCROLL/MICRO↓** until the desired value for MPL is displayed.
7. Press **ENTER**.

An asterisk (*) will be displayed in front of the selected value.

8. Press **START** or **RETURN** to exit the Menu. See “Exiting the Configuration Menu” on page 39.

Perforation skipping

Use this parameter to create a bottom margin on your printed page, if the host data stream does not create a bottom margin.

The range of values is 0 to 879 lines, at 8 lpi. The default value is 0.

To change or check perforation skipping, follow these steps:

1. Press **MENU**.
2. Press **SCROLL/MICRO↑** or **SCROLL/MICRO↓**. The printer displays

```
CONFIGURATION MENU
ASCII Configuration
```

3. Press **ENTER**.
4. Press **SCROLL/MICRO↑** or **SCROLL/MICRO↓**. The printer displays

```
ASCII Configuration
Perforation Skipping
```

5. Press **ENTER** to display the current value.
6. Press **SCROLL/MICRO↑** or **SCROLL/MICRO↓** until the desired Perforation Skipping value is displayed.
7. Press **ENTER**.
An asterisk (*) will be displayed in front of the selected value.
8. Press **START** or **RETURN** to exit the Menu. See “Exiting the Configuration Menu” on page 39.

Emulation Mode

You can set Emulation Mode to the following values:

- 4247 (Default)
- 2381 Personal Printer
- 4202 Proprinter III XL
- Epson-FX

Note: The printer performs a partial reset to put any change to this parameter value into effect when you exit the Configuration Menu with **START** or **RETURN**. Buffered data will be lost.

To change or check the emulation mode, follow these steps:

1. Press **MENU**.
2. Press **SCROLL/MICRO↑** or **SCROLL/MICRO↓** until the printer displays

```
CONFIGURATION MENU
ASCII Configuration
```

3. Press **ENTER**.
4. Press **SCROLL/MICRO↑** or **SCROLL/MICRO↓** until the printer displays

```
ASCII Configuration
Emulation Mode
```

5. Press **ENTER** to display the current value.
6. Press **SCROLL/MICRO↑** or **SCROLL/MICRO↓** until the desired value for Emulation Mode is displayed.

7. Press **ENTER**.
An asterisk (*) will be displayed in front of the selected value.
8. Press **START** or **RETURN** to exit the Menu. See “Exiting the Configuration Menu” on page 39.

Print language

The following print languages are available on the printer when attachment is set to Parallel, Serial, USB, or LAN ASCII. The defaults are marked with an asterisk (*). You can select any print language that is available for your printer.

Determine the value for the language setting you want from the following tables:

Code Page (When emulation is set to Epson-FX)	Code Page (When emulation is set to 4247, 4202 III XL, 2381 Personal Printer)	Language
0(*)	N/A	USA
1	N/A	France
2	N/A	Germany
3	N/A	U.K.
4	N/A	Denmark I
5	N/A	Sweden
6	N/A	Italy
7	N/A	Spain I
8	N/A	Japan
9	N/A	Norway
10	N/A	Denmark II
11	N/A	Spain II
12	N/A	Latin America I
13	N/A	French Canadian
14	N/A	Latin American II
N/A	437(*)	USA PC A-54
N/A	737	Greek (MS DOS)
N/A	813	Greek/Latin (ISO 8859-7)
N/A	819	Latin 1 (ISO 8859-1)
N/A	850	PC Multilingual
N/A	851	Greek (Old)
N/A	852	Latin 2/ROECE
N/A	853	Latin 3 PC
N/A	855	Cyrillic PC
N/A	857	Latin 5 Turkey + euro
N/A	858	euro PC Multilingual + euro
N/A	860	Portuguese
N/A	861	Icelandic
N/A	862	Hebrew

Code Page (When emulation is set to Epson-FX)	Code Page (When emulation is set to 4247, 4202 III XL, 2381 Personal Printer)	Language
N/A	863	Canadian French
N/A	864	Arabic
N/A	865	Danish/Norwegian
N/A	866	PC Data, Cyrillic, Russian
N/A	869	Greek (New) + euro
N/A	874	Thai
N/A	876	OCR-A
N/A	877	OCR-B
N/A	912	Latin 2 (ISO 8859-2)
N/A	913	Latin 3 (ISO 8859-3)
N/A	914	Latin 4 (ISO 8859-4)
N/A	915	Cyrillic (ISO 8859-5)
N/A	916	Latin 8 (ISO 8859-8)
N/A	920	Latin 5 (ISO 8859-9)
N/A	921	Baltic Multilingual
N/A	922	Estonian
N/A	923	Latin 9 (ISO8859-15)
N/A	1006	Urdu
N/A	1046	Arabic Extended
N/A	1089	Latin 6 (ISO 8859-6)
N/A	1098	Farsi PC
N/A	1116	Estonia PC
N/A	1117	Latvia PC
N/A	1118	Lithuania PC
N/A	1250	Central Europe Latin 2
N/A	1251	Cyrillic Windows + euro

Notes:

1. The printer performs a partial reset to put any change to this parameter value into effect when you exit the Configuration Menu with **START** or **RETURN**. Buffered data will be lost.
2. This parameter can be overridden by the computer.
3. When either OCR-A or OCR-B is selected, the selectable options for CPI and print quality become fixed at 10 CPI and Near Letter Quality, respectively.

To change or check the print language value, follow these steps:

1. Press **MENU**.
2. Press **SCROLL/MICRO↑** or **SCROLL/MICRO↓** until the printer displays

CONFIGURATION MENU ASCII Configuration

3. Press **ENTER**.

4. Press **SCROLL/MICRO** or **SCROLL/MICRO** until the printer displays

```
ASCII Configuration
Print Language
```

5. Press **ENTER** to display the current value.
6. Press **SCROLL/MICRO** or **SCROLL/MICRO** until the desired language value is displayed.
7. Press **ENTER**.
An asterisk (*) will be displayed in front of the selected value.
8. Press **START** or **RETURN** to exit the Menu. See “Exiting the Configuration Menu” on page 39.

Print quality

When emulation mode is set to 4247, 4202 III XL, or 2381 Personal Printer, you can set the printer to any of the following values:

- **DP (Data Processing) Quality** (Default)
- **DP Text Quality**
- **Near Letter Quality**
- **OCR-A**
- **OCR-B**

When emulation mode is set to Epson-FX, you can set the printer to any of the following values:

- **DP Quality** (Default)
- **Courier**
- **Gothic**
- **OCR-A**
- **OCR-B**

Notes:

1. This parameter can be overridden by the computer.
2. Only OCR-A and OCR-B are valid when either OCR-A or OCR-B is selected as the print language.

To change or check the Print Quality, follow these steps:

1. Press **MENU**.
2. Press **SCROLL/MICRO** or **SCROLL/MICRO** until the printer displays

```
CONFIGURATION MENU
ASCII Configuration
```

3. Press **ENTER**.
4. Press **SCROLL/MICRO** or **SCROLL/MICRO** until the printer displays

```
ASCII Configuration
Print Quality
```

5. Press **ENTER** to display the current value.
6. Press **SCROLL/MICRO** or **SCROLL/MICRO** until the desired value for Print Quality is displayed.
7. Press **ENTER**.
An asterisk (*) will be displayed in front of the selected value.

8. Press **START** or **RETURN** to exit the Menu. See “Exiting the Configuration Menu” on page 39.

NLQ typeface

This parameter is displayed when emulation mode is set to 4247, 4202 III XL, or 2381 Personal Printer. This parameter allows you to set the font to be used for Near Letter Quality printing. The following values are:

- **Courier** (Default)
- **Gothic**

To change or check the NLQ Typeface, follow these steps:

1. Press **MENU**.
2. Press **SCROLL/MICRO↑** or **SCROLL/MICRO↓** until the printer displays

```
CONFIGURATION MENU
ASCII Configuration
```

3. Press **ENTER**.
4. Press **SCROLL/MICRO↑** or **SCROLL/MICRO↓** until the printer displays

```
CONFIGURATION MENU
NLQ Typeface
```

5. Press **ENTER** to display the current value.
6. Press **SCROLL/MICRO↑** or **SCROLL/MICRO↓** until the desired value for NLQ Typeface is displayed.
7. Press **ENTER**.
An asterisk (*) will be displayed in front of the selected value.
8. Press **START** or **RETURN** to exit the Menu. See “Exiting the Configuration Menu” on page 39.

Character set

You can set the character set to any of the following values:

- **PC1** (PC Character Set 1) (Default)
- **PC2** (PC Character Set 2)
- **Italic** (Epson-FX only)

To change or check the Character Set, follow these steps:

1. Press **MENU**.
2. Press **SCROLL/MICRO↑** or **SCROLL/MICRO↓** until the printer displays

```
CONFIGURATION MENU
ASCII Configuration
```

3. Press **ENTER**.
4. Press **SCROLL/MICRO↑** or **SCROLL/MICRO↓** until the printer displays

```
ASCII Configuration
Character Set
```

5. Press **ENTER** to display the current value.

6. Press **SCROLL/MICRO**↑ or **SCROLL/MICRO**↓ until the desired value for Character Set is displayed.
7. Press **ENTER**.
An asterisk (*) will be displayed in front of the selected value.
8. Press **START** or **RETURN** to exit the Menu. See “Exiting the Configuration Menu” on page 39.

Printer Compatibility 3 (automatic line feed on carriage return)

You can set the printer to perform an automatic line feed on carriage return. You can set this value to:

- Disabled** (Default) No line feed is performed after a carriage return.
Enabled An automatic line feed is performed after a carriage return.

To change or check the automatic line feed on carriage return setting, follow these steps:

1. Press **MENU**.
2. Press **SCROLL/MICRO**↑ or **SCROLL/MICRO**↓ until the printer displays

```
CONFIGURATION MENU
ASCII Configuration
```

3. Press **ENTER**.
4. Press **SCROLL/MICRO**↑ or **SCROLL/MICRO**↓ until the printer displays

```
ASCII Configuration
Printer Compatibility
```

5. Press **ENTER**.
6. Press **SCROLL/MICRO**↑ or **SCROLL/MICRO**↓ until the printer displays

```
Printer Compatibility
3 (Auto LF on CR)
```

7. Press **ENTER** to display the current value.
8. Press **SCROLL/MICRO**↑ or **SCROLL/MICRO**↓ until the desired value for Automatic Line Feed on Carriage Return is displayed.
9. Press **ENTER**.
An asterisk (*) will be displayed in front of the selected value.
10. Press **START** or **RETURN** to exit the Menu. See “Exiting the Configuration Menu” on page 39.

Printer Compatibility 4 (automatic carriage return on line feed)

This parameter is displayed when emulation mode is set to 4247, 4202 III XL, or 2381 Personal Printer.

You can set the printer to perform an automatic carriage return on a line feed. You can set this value to:

- Disabled** (Default) No automatic carriage return is performed after a line feed.
Enabled An automatic carriage return is performed after a line feed.

Note: If Emulation Mode is set to Epson-FX, an automatic carriage return is performed after a line feed regardless of the setting.

To change or check the automatic carriage return after a line feed setting, follow these steps:

1. Press **MENU**.
2. Press **SCROLL/MICRO↑** or **SCROLL/MICRO↓** until the printer displays

```
CONFIGURATION MENU
ASCII Configuration
```

3. Press **ENTER**.
4. Press **SCROLL/MICRO↑** or **SCROLL/MICRO↓** until the printer displays

```
ASCII Configuration
Printer Compatibility
```

5. Press **ENTER**.
6. Press **SCROLL/MICRO↑** or **SCROLL/MICRO↓** until the printer displays

```
Printer Compatibility
4 (Auto CR on LF)
```

7. Press **ENTER** to display the current value.
8. Press **SCROLL/MICRO↑** or **SCROLL/MICRO↓** until the desired value for Automatic Carriage Return on Line Feed is displayed.
9. Press **ENTER**.
An asterisk (*) will be displayed in front of the selected value.
10. Press **START** or **RETURN** to exit the Menu. See “Exiting the Configuration Menu” on page 39.

Printer Compatibility 5 (form feed suppression)

This parameter is displayed when emulation mode is set to 4247, 4202 III XL, or 2381 Personal Printer.

You can set the printer to suppress host form feed commands or to honor all host form feeds. You can set this value to:

- Disabled** (Default) All form feed commands from the host are honored.
Enabled Form feed commands from the host are ignored if the printer is at top of form and no data for the page was received.

Note: Operator panel form feeds are not affected.

To change or check form feed suppression, follow these steps:

1. Press **MENU**.
2. Press **SCROLL/MICRO↑** or **SCROLL/MICRO↓** until the printer displays

```
CONFIGURATION MENU
ASCII Configuration
```

3. Press **ENTER**.
4. Press **SCROLL/MICRO↑** or **SCROLL/MICRO↓** until the printer displays

```
ASCII Configuration
Printer Compatibility
```

5. Press **ENTER**.
6. Press **SCROLL/MICRO↑** or **SCROLL/MICRO↓** until the printer displays

```
Printer Compatibility
5 (FF Suppression)
```

7. Press **ENTER** to display the current value.
8. Press **SCROLL/MICRO↑** or **SCROLL/MICRO↓** until the desired value for Form Feed Suppression is displayed.
9. Press **ENTER**.
An asterisk (*) will be displayed in front of the selected value.
10. Press **START** or **RETURN** to exit the Menu. See “Exiting the Configuration Menu” on page 39.

Printer Compatibility 6 (Init)

You can set the printer to detect the Init signal and perform a partial reset when active or to ignore the signal. You can set this value to:

Disabled	Init signal detection disabled. No action occurs when Init is activated.
Enabled (Default)	Init signal detection enabled. When Init is activated, the printer performs a partial reset.

To change or check the Init signal, follow these steps:

1. Press **MENU**.
2. Press **SCROLL/MICRO↑** or **SCROLL/MICRO↓** until the printer displays

```
CONFIGURATION MENU
ASCII Configuration
```

3. Press **ENTER**.
4. Press **SCROLL/MICRO↑** or **SCROLL/MICRO↓** until the printer displays

```
ASCII Configuration
Printer Compatibility
```

5. Press **ENTER**.
6. Press **SCROLL/MICRO↑** or **SCROLL/MICRO↓** until the printer displays

```
Printer Compatibility
6 (Init)
```

7. Press **ENTER** to display the current value.
8. Press **SCROLL/MICRO↑** or **SCROLL/MICRO↓** until the desired value for Init is displayed.

9. Press **ENTER**.
An asterisk (*) will be displayed in front of the selected value.
10. Press **START** or **RETURN** to exit the Menu. See “Exiting the Configuration Menu” on page 39.

Printer Compatibility 7 (condensed print)

This parameter is displayed when emulation mode is set to 4247, 4202 III XL, or 2381 Personal Printer.

You can set the printer CPI value for condensed print when a Shift In control is received from the data stream. For more information, see the *4247 Model X03 Printer Programmer Manual*.

You can set this value to:

- **15**
- **16.7**
- **17.1** (Default)

To change or check condensed print, follow these steps:

1. Press **MENU**.
2. Press **SCROLL/MICRO↑** or **SCROLL/MICRO↓** until the printer displays

```
CONFIGURATION MENU
ASCII Configuration
```

3. Press **ENTER**.
4. Press **SCROLL/MICRO↑** or **SCROLL/MICRO↓** until the printer displays

```
ASCII Configuration
Printer Compatibility
```

5. Press **ENTER**.
6. Press **SCROLL/MICRO↑** or **SCROLL/MICRO↓** until the printer displays

```
Printer Compatibility
7 (Condensed Print)
```

7. Press **ENTER** to display the current value.
8. Press **SCROLL/MICRO↑** or **SCROLL/MICRO↓** until the desired value for Condensed Print is displayed.
9. Press **ENTER**.
An asterisk (*) will be displayed in front of the selected value.
10. Press **START** or **RETURN** to exit the Menu. See “Exiting the Configuration Menu” on page 39.

Printer Compatibility 8 (slashed zero)

You can set this value to:

- | | |
|------------------------------|--|
| Disabled
(Default) | All printed zeros will appear without a slash. |
| Enabled | All printed zeros will appear with a slash. |

To change or check the slashed zero, follow these steps:

1. Press **MENU**.
2. Press **SCROLL/MICRO↑** or **SCROLL/MICRO↓** until the printer displays

```
CONFIGURATION MENU
ASCII Configuration
```

3. Press **ENTER**.
4. Press **SCROLL/MICRO↑** or **SCROLL/MICRO↓** until the printer displays

```
ASCII Configuration
Printer Compatibility
```

5. Press **ENTER**.
6. Press **SCROLL/MICRO↑** or **SCROLL/MICRO↓** until the printer displays

```
Printer Compatibility
8 (Slashed Zero)
```

7. Press **ENTER** to display the current value.
8. Press **SCROLL/MICRO↑** or **SCROLL/MICRO↓** until the desired value for Slashed Zero is displayed.
9. Press **ENTER**.
An asterisk (*) will be displayed in front of the selected value.
10. Press **START** or **RETURN** to exit the Menu. See “Exiting the Configuration Menu” on page 39.

Printer Compatibility 9 (20 CPI)

This parameter is displayed when emulation mode is set to 4247, 4202 III XL, or 2381 Personal Printer.

You can set the printer to allow 20 CPI condensed print from the data stream. For more information, see the *4247 Model X03 Printer Programmer Manual*.

You can set this value to:

Disabled	Does not allow 20 CPI to be accessed by the data stream.
Enabled (Default)	Allows 20 CPI to be accessed by the data stream.

To change or check 20 CPI, follow these steps:

1. Press **MENU**.
2. Press **SCROLL/MICRO↑** or **SCROLL/MICRO↓** until the printer displays

```
CONFIGURATION MENU
ASCII Configuration
```

3. Press **ENTER**.
4. Press **SCROLL/MICRO↑** or **SCROLL/MICRO↓** until the printer displays

```
ASCII Configuration
Printer Compatibility
```

5. Press **ENTER**.
6. Press **SCROLL/MICRO↑** or **SCROLL/MICRO↓** until the printer displays

```
Printer Compatibility
9 (20 CPI)
```

7. Press **ENTER** to display the current value.
8. Press **SCROLL/MICRO↑** or **SCROLL/MICRO↓** until the desired value for 20 CPI mode is displayed.
9. Press **ENTER**.
An asterisk (*) will be displayed in front of the selected value.
10. Press **START** or **RETURN** to exit the Menu. See “Exiting the Configuration Menu” on page 39.

Alarm control

You can set the audible printer alarm to either of the following values:

- **Enabled** (Default)
- **Disabled**

Note: Pressing **Set Top of Form**, and some unit check conditions sound the alarm, even if the alarm is disabled.

To change or check the alarm control, follow these steps:

1. Press **MENU**.
2. Press **SCROLL/MICRO↑** or **SCROLL/MICRO↓** until the printer displays

```
CONFIGURATION MENU
ASCII Configuration
```

3. Press **ENTER**.
4. Press **SCROLL/MICRO↑** or **SCROLL/MICRO↓** until the printer displays

```
ASCII Configuration
Alarm Control
```

5. Press **ENTER** to display the current value.
6. Press **SCROLL/MICRO↑** or **SCROLL/MICRO↓** until the desired value for Alarm Control is displayed.
7. Press **ENTER**.
An asterisk (*) will be displayed in front of the selected value.
8. Press **START** or **RETURN** to exit the Menu. See “Exiting the Configuration Menu” on page 39.

Override Host parameters

Note: **Override Host** is not available for IPDS.

Paper source

This parameter allows the printer to accept or ignore (override) the Paper Source selection commands that are sent by the host data stream. You can set Paper Source to:

- Disabled** (Default) The printer **accepts** and processes commands received from the host data stream for paper source selection.
- Enabled** The printer **ignores** commands received from the host data stream that specify paper source selection. The printer will use the paper source selected at the operator panel. Commands sent from the host cannot override the paper source selected at the operator panel.

To change or check the Paper Source:

1. Press **MENU**.
2. Press **SCROLL/MICRO↑** or **SCROLL/MICRO↓** until the printer displays

```
CONFIGURATION MENU
ASCII Configuration
```

3. Press **ENTER**.
4. Press **SCROLL/MICRO↑** or **SCROLL/MICRO↓** until the printer displays

```
ASCII Configuration
Override Host
```

5. Press **ENTER**, and the printer displays

```
Override Host
Paper Source
```

6. Press **ENTER** to display the current value.
7. Press **SCROLL/MICRO↑** or **SCROLL/MICRO↓** until the desired value for Paper Source is displayed.
8. Press **ENTER**.
An asterisk (*) will be displayed in front of the selected value.
9. Press **START** or **RETURN** to exit the Menu. See “Exiting the Configuration Menu” on page 39.

Characters Per Inch (CPI)

This parameter allows the printer to accept or ignore (override) the Characters Per Inch commands that are sent by the host data stream. You can set Characters Per Inch to:

- Disabled (Default)** The printer **accepts** and processes commands received from the host data stream, for Characters Per Inch selection.
- Enabled** The printer **ignores** commands received from the host data stream, for Characters Per Inch. The printer will use the Characters Per Inch value set in the printer configuration.

To change or check the Characters Per Inch setting:

1. Press **MENU**.
2. Press **SCROLL/MICRO↑** or **SCROLL/MICRO↓** until the printer displays

```
CONFIGURATION MENU
ASCII Configuration
```

3. Press **ENTER**.
4. Press **SCROLL/MICRO↑** or **SCROLL/MICRO↓** until the printer displays

```
ASCII Configuration
Override Host
```

5. Press **ENTER**, and the printer displays
6. Press **SCROLL/MICRO↑** or **SCROLL/MICRO↓** until the printer plays

```
Override Host
Characters Per Inch
```

7. Press **ENTER** to display the current value.
8. Press **SCROLL/MICRO↑** or **SCROLL/MICRO↓** until the desired value for Characters Per Inch is displayed.
9. Press **ENTER** to display the current value.
An asterisk (*) is displayed in front of the selected value.
10. Press **START** or **RETURN** to exit the Menu. See “Exiting the Configuration Menu” on page 39.

Lines Per Inch (LPI)

This parameter allows the printer to accept or ignore (override) the Lines Per Inch commands that are sent by the host data stream. You can set Lines Per Inch to:

- Disabled** (Default) The printer **accepts** and processes commands received from the host data stream for Lines Per Inch selection.
- Enabled** The printer **ignores** commands received from the host data stream for Characters Per Inch. The printer will use the Lines Per Inch value set in the printer configuration.

To change or check the Lines Per Inch setting:

1. Press **MENU**.
2. Press **SCROLL/MICRO↑** or **SCROLL/MICRO↓** until the printer displays

```
CONFIGURATION MENU
ASCII Configuration
```

3. Press **ENTER**.
4. Press **SCROLL/MICRO↑** or **SCROLL/MICRO↓** until the printer displays

```
ASCII Configuration
Override Host
```

5. Press **ENTER**, and the printer displays
6. Press **SCROLL/MICRO↑** or **SCROLL/MICRO↓** until the printer plays

```
Override Host
Lines Per Inch
```

7. Press **ENTER** to display the current value.
8. Press **SCROLL/MICRO↑** or **SCROLL/MICRO↓** until the desired value for Lines Per Inch is displayed.
9. Press **ENTER** to display the current value.
An asterisk (*) is displayed in front of the selected value.
10. Press **START** or **RETURN** to exit the Menu. See “Exiting the Configuration Menu” on page 39.

Maximum Page Length

This parameter allows the printer to accept or ignore (override) the Maximum Page Length commands that are sent by the host data stream. You can set Maximum Page Length to:

- Disabled (Default)** The printer **accepts** and processes commands received from the host data stream for Maximum Page Length selection.
- Enabled** The printer **ignores** commands received from the host data stream for Maximum Page Length. The printer will use the Maximum Page Length value set in the printer configuration.

Disabled (Default)

Enabled

To change or check the Maximum Page Length setting:

1. Press **MENU**.
2. Press **SCROLL/MICRO↑** or **SCROLL/MICRO↓** until the printer displays

```
CONFIGURATION MENU
ASCII Configuration
```

3. Press **ENTER**.
4. Press **SCROLL/MICRO↑** or **SCROLL/MICRO↓** until the printer displays

```
ASCII Configuration
Override Host
```

5. Press **ENTER**, and the printer displays
6. Press **SCROLL/MICRO↑** or **SCROLL/MICRO↓** until the printer plays

```
Override Host
Maximum Page Length
```

7. Press **ENTER** to display the current value.
8. Press **SCROLL/MICRO↑** or **SCROLL/MICRO↓** until the desired value for Maximum Page Length is displayed.
9. Press **ENTER** to display the current value.
An asterisk (*) is displayed in front of the selected value.
10. Press **START** or **RETURN** to exit the Menu. See “Exiting the Configuration Menu” on page 39.

Parallel interface

Interface type

This parameter allows you to set the system interface for the parallel attachment. You can set Interface Type to either of the following values:

- **PC Parallel** (Default)
- **1284 Parallel**

To change or check the Interface Type:

1. Press **MENU**.
2. Press **SCROLL/MICRO↑** or **SCROLL/MICRO↓** until the printer displays

```
CONFIGURATION MENU
ASCII Configuration
```

3. Press **ENTER**.
4. Press **SCROLL/MICRO↑** or **SCROLL/MICRO↓** until the printer displays

```
ASCII Configuration
Parallel Interface
```

5. Press **ENTER**.
6. Press **SCROLL/MICRO↑** or **SCROLL/MICRO↓** until the printer displays

```
Parallel Interface
Interface Type
```

7. Press **ENTER** to display the current value.
8. Press **SCROLL/MICRO↑** or **SCROLL/MICRO↓** until the desired value for Interface Type is displayed.
9. Press **ENTER**.
An asterisk (*) will be displayed in front of the selected value.
10. Press **START** or **RETURN** to exit the Menu. See “Exiting the Configuration Menu” on page 39.

Input Buffer Size

This parameter allows you to select the size of input buffer to be used. The following values are:

- **256**
- **2K**
- **12K**
- **32K** (Default)
- **64K**
- **128K**

To change or check the Input Buffer Size:

1. Press **MENU**.
2. Press **SCROLL/MICRO↑** or **SCROLL/MICRO↓** until the printer displays

```
CONFIGURATION MENU
ASCII Configuration
```

3. Press **ENTER**.

4. Press **SCROLL/MICRO**↑ or **SCROLL/MICRO**↓ until the printer displays

```
ASCII Configuration
Parallel Interface
```

5. Press **ENTER**.
6. Press **SCROLL/MICRO**↑ or **SCROLL/MICRO**↓ until the printer displays

```
Parallel Interface
Input Buffer Size
```

7. Press **ENTER** to display the current value.
8. Press **SCROLL/MICRO**↑ or **SCROLL/MICRO**↓ until the desired value for Input Buffer Size is displayed.
9. Press **ENTER**.
An asterisk (*) will be displayed in front of the selected value.
10. Press **START** or **RETURN** to exit the Menu. See “Exiting the Configuration Menu” on page 39.

Select-In

This parameter is valid in Epson-FX emulation mode only and instructs the printer how to handle Select-In Signals. You can set the Select-In Signal to:

- Disabled** The Select-In Signal is ignored and treated as always on.
Enabled (Default) The printer checks the Select-In Signal from the host.

To change or check the Select-In Signal:

1. Press **MENU**.
2. Press **SCROLL/MICRO**↑ or **SCROLL/MICRO**↓ until the printer displays

```
CONFIGURATION MENU
ASCII Configuration
```

3. Press **ENTER**.
4. Press **SCROLL/MICRO**↑ or **SCROLL/MICRO**↓ until the printer displays

```
ASCII Configuration
Parallel Interface
```

5. Press **ENTER**.
6. Press **SCROLL/MICRO**↑ or **SCROLL/MICRO**↓ until the printer displays

```
Parallel Interface
Select-In
```

7. Press **ENTER** to display the current value.
8. Press **SCROLL/MICRO**↑ or **SCROLL/MICRO**↓ until the desired value for Select-In Signal is displayed.
9. Press **ENTER**.
An asterisk (*) will be displayed in front of the selected value.
10. Press **START** or **RETURN** to exit the Menu. See “Exiting the Configuration Menu” on page 39.

AutoFeed-XT

This parameter is valid in Epson-FX emulation mode only and instructs the printer whether the host will determine if an automatic line feed is performed after a carriage return.

You can set this value to:

- Disabled** (Default) The function is determined by the setting of Printer Compatibility 3 – Automatic Line Feed on Carriage Return.
- Enabled** The host determines whether an automatic line feed is performed after a carriage return.

To change or check the AutoFeed-XT setting, follow these steps:

1. Press **MENU**.
2. Press **SCROLL/MICRO↑** or **SCROLL/MICRO↓** until the printer displays

```
CONFIGURATION MENU
ASCII Configuration
```

3. Press **ENTER**.
4. Press **SCROLL/MICRO↑** or **SCROLL/MICRO↓** until the printer displays

```
ASCII Configuration
Parallel Interface
```

5. Press **ENTER**.
6. Press **SCROLL/MICRO↑** or **SCROLL/MICRO↓** until the printer displays

```
Parallel Interface
AutoFeed-XT
```

7. Press **ENTER** to display the current value.
8. Press **SCROLL/MICRO↑** or **SCROLL/MICRO↓** until the desired value for AutoFeed XT is displayed.
9. Press **ENTER**.
An asterisk (*) will be displayed in front of the selected value.
10. Press **START** or **RETURN** to exit the Menu. See “Exiting the Configuration Menu” on page 39.

Serial interface

Interface type

This parameter allows you to select the Serial Interface attachment type. You can set Interface Type to:

- **RS-232C** (Default)

To change or check the Interface Type:

1. Press **MENU**.
2. Press **SCROLL/MICRO↑** or **SCROLL/MICRO↓** until the printer displays

```
CONFIGURATION MENU
ASCII Configuration
```

3. Press **ENTER**.
4. Press **SCROLL/MICRO↑** or **SCROLL/MICRO↓** until the printer displays

```
ASCII Configuration
Serial Interface
```

5. Press **ENTER** to display

```
Serial Interface
Interface Type
```

6. Press **ENTER** to display the current value.
7. Press **SCROLL/MICRO↑** or **SCROLL/MICRO↓** until the desired value for Interface Type is displayed.
8. Press **ENTER**.
An asterisk (*) will be displayed in front of the selected value.
9. Press **START** or **RETURN** to exit the Menu. See “Exiting the Configuration Menu” on page 39.

Input Buffer Size

You can set the Input Buffer Size to:

- 256
- 2K
- 12K
- 32K (Default)
- 64K
- 128K

To change or check the Input Buffer Size:

1. Press **MENU**.
2. Press **SCROLL/MICRO↑** or **SCROLL/MICRO↓** until the printer displays

```
CONFIGURATION MENU
ASCII Configuration
```

3. Press **ENTER**.
4. Press **SCROLL/MICRO↑** or **SCROLL/MICRO↓** until the printer displays

```
ASCII Configuration
Serial Interface
```

5. Press **ENTER** and the printer displays

```
Serial Interface
Input Buffer Size
```

6. Press **ENTER** to display the current value.
7. Press **SCROLL/MICRO↑** or **SCROLL/MICRO↓** until the desired value for Input Buffer Size is displayed.
8. Press **ENTER**.
An asterisk (*) will be displayed in front of the selected value.
9. Press **START** or **RETURN** to exit the Menu. See “Exiting the Configuration Menu” on page 39.

Data Bits

You can set the size of Input Buffer to:

- 7
- 8 (Default)

To change or check the Input Buffer Size:

1. Press **MENU**.
2. Press **SCROLL/MICRO↑** or **SCROLL/MICRO↓** until the printer displays

```
CONFIGURATION MENU
ASCII Configuration
```

3. Press **ENTER**.
4. Press **SCROLL/MICRO↑** or **SCROLL/MICRO↓** until the printer displays

```
ASCII Configuration
Serial Interface
```

5. Press **ENTER** and the printer displays

```
Serial Interface
Data Bits
```

6. Press **ENTER** to display the current value.
7. Press **SCROLL/MICRO↑** or **SCROLL/MICRO↓** until the desired value for Data Bits is displayed.
8. Press **ENTER**.
An asterisk (*) will be displayed in front of the selected value.
9. Press **START** or **RETURN** to exit the Menu. See “Exiting the Configuration Menu” on page 39.

Baud Rate

You can set the size of Baud Rate to:

- 300
- 600
- 1200
- 2400
- 4800
- 9600 (Default)
- 19200
- 38400
- 115200

To change or check the Baud Rate:

1. Press **MENU**.
2. Press **SCROLL/MICRO↑** or **SCROLL/MICRO↓** until the printer displays

```
CONFIGURATION MENU
ASCII Configuration
```

3. Press **ENTER**.
4. Press **SCROLL/MICRO↑** or **SCROLL/MICRO↓** until the printer displays

```
ASCII Configuration
Serial Interface
```

5. Press **ENTER** and the printer displays

```
Serial Interface
Baud Rate
```

6. Press **ENTER** to display the current value.
7. Press **SCROLL/MICRO↑** or **SCROLL/MICRO↓** until the desired value for Baud Rate is displayed.
8. Press **ENTER**.
An asterisk (*) will be displayed in front of the selected value.
9. Press **START** or **RETURN** to exit the Menu. See “Exiting the Configuration Menu” on page 39.

Parity

You can set the Parity to:

- **None** (Default)
- **Odd**
- **Even**
- **Mark**
- **Space**

To change or check the Parity setting:

1. Press **MENU**.
2. Press **SCROLL/MICRO↑** or **SCROLL/MICRO↓** until the printer displays

```
CONFIGURATION MENU
ASCII Configuration
```

3. Press **ENTER**.
4. Press **SCROLL/MICRO↑** or **SCROLL/MICRO↓** until the printer displays

```
ASCII Configuration
Serial Interface
```

5. Press **ENTER** and the printer displays

```
Serial Interface
Parity
```

6. Press **ENTER** to display the current value.
7. Press **SCROLL/MICRO↑** or **SCROLL/MICRO↓** until the desired value for Parity is displayed.
8. Press **ENTER**.
An asterisk (*) will be displayed in front of the selected value.
9. Press **START** or **RETURN** to exit the Menu. See “Exiting the Configuration Menu” on page 39.

Pacing Control

You can set the Pacing Protocol to:

- **DTR** (Default)
- **XON/XOF**

To change or check the Pacing Protocol setting:

1. Press **MENU**.
2. Press **SCROLL/MICRO↑** or **SCROLL/MICRO↓** until the printer displays

```
CONFIGURATION MENU
ASCII Configuration
```

3. Press **ENTER**.
4. Press **SCROLL/MICRO↑** or **SCROLL/MICRO↓** until the printer displays

```
ASCII Configuration
Serial Interface
```

5. Press **ENTER** and the printer displays

```
Serial Interface
Pacing Protocol
```

6. Press **ENTER** to display the current value.
7. Press **SCROLL/MICRO↑** or **SCROLL/MICRO↓** until the desired value for Pacing Protocol is displayed.
8. Press **ENTER**.
An asterisk (*) will be displayed in front of the selected value.
9. Press **START** or **RETURN** to exit the Menu. See “Exiting the Configuration Menu” on page 39.

Connection Type

You can set Connection Type to:

Local Printer is connected locally to a host computer.
(Default)

Remote Printer is connected remotely to a host computer through an external modem.

To change or check the Connection Type setting:

1. Press **MENU**.
2. Press **SCROLL/MICRO↑** or **SCROLL/MICRO↓** until the printer displays

```
CONFIGURATION MENU
ASCII Configuration
```

3. Press **ENTER**.
4. Press **SCROLL/MICRO↑** or **SCROLL/MICRO↓** until the printer displays

```
ASCII Configuration
Serial Interface
```

5. Press **ENTER** and the printer displays

```
Serial Interface
Connection Type
```

6. Press **ENTER** to display the current value.
7. Press **SCROLL/MICRO↑** or **SCROLL/MICRO↓** until the desired value for Connection Type is displayed.
8. Press **ENTER**.
An asterisk (*) will be displayed in front of the selected value.
9. Press **START** or **RETURN** to exit the Menu. See “Exiting the Configuration Menu” on page 39.

LAN Interface

IP Address Assignment

You can set the IP Address Assignment to:

- **Fixed** (Default)
- **DHCP**

To change or check the IP Address Assignment:

1. Press **MENU**.
2. Press **SCROLL/MICRO↑** or **SCROLL/MICRO↓** until the printer displays

```
CONFIGURATION MENU
ASCII Configuration
```

3. Press **ENTER**.
4. Press **SCROLL/MICRO↑** or **SCROLL/MICRO↓** until the printer displays

```
ASCII Configuration
LAN Interface
```

5. Press **ENTER** and the printer displays

```
LAN Interface
IP Address Assignment
```

6. Press **ENTER** to display the current value.
7. Press **SCROLL/MICRO↑** or **SCROLL/MICRO↓** until the desired value for IP Address Assignment is displayed.
8. Press **ENTER**.
An asterisk (*) will be displayed in front of the selected value.
9. Press **START** or **RETURN** to exit the Menu. See “Exiting the Configuration Menu” on page 39.

IP Address

You can set the IP Address:

Example: **127.000.000.000** (Default)

IP Address values are represented by a decimal notation. The decimal values are divided into four fields by periods. Each field's values can be between 0 and 255.

To change or check the IP Address:

1. Press **MENU**.
2. Press **SCROLL/MICRO↑** or **SCROLL/MICRO↓** until the printer displays

```
CONFIGURATION MENU
ASCII Configuration
```

3. Press **ENTER**.
4. Press **SCROLL/MICRO↑** or **SCROLL/MICRO↓** until the printer displays

```
ASCII Configuration
LAN Interface
```

5. Press **ENTER** and the printer displays

```
LAN Interface
IP Address
```

6. Press **ENTER** to display the current value.
7. Press **SCROLL/MICRO↑** or **SCROLL/MICRO↓** until the desired value for IP Address is displayed.
8. Press **ENTER**.
An asterisk (*) will be displayed in front of the selected value.
9. Press **START** or **RETURN** to exit the Menu. See “Exiting the Configuration Menu” on page 39.

Subnet Mask

You can set the Subnet Mask:

Example: **255.255.254.000** (Default)

These values set the Subnet Mask number. This number is represented by a decimal notation. The decimal values are divided into four fields by periods. Each field's values can range from 0 to 255.

To change or check the Subnet Mask:

1. Press **MENU**.
2. Press **SCROLL/MICRO↑** or **SCROLL/MICRO↓** until the printer displays

```
CONFIGURATION MENU
ASCII Configuration
```

3. Press **ENTER**.
4. Press **SCROLL/MICRO↑** or **SCROLL/MICRO↓** until the printer displays

```
ASCII Configuration
LAN Interface
```

5. Press **ENTER** and the printer displays

```
LAN Interface
Subnet Mask
```

6. Press **ENTER** to display the current value.
7. Press **SCROLL/MICRO↑** or **SCROLL/MICRO↓** until the desired value for Subnet Mask is displayed.

8. Press **ENTER**.
An asterisk (*) will be displayed in front of the selected value.
9. Press **START** or **RETURN** to exit the Menu. See “Exiting the Configuration Menu” on page 39.

Default Gateway

You can set the Default Gateway:
Example: 000.000.000.000 (Default)

These values set the Default Gateway address. This number is represented by a decimal notation. The decimal values are divided into four fields by periods. Each field's values can range from 0 to 255.

To change or check the Default Gateway:

1. Press **MENU**.
2. Press **SCROLL/MICRO↑** or **SCROLL/MICRO↓** until the printer displays

```
CONFIGURATION MENU
ASCII Configuration
```

3. Press **ENTER**.
4. Press **SCROLL/MICRO↑** or **SCROLL/MICRO↓** until the printer displays

```
ASCII Configuration
LAN Interface
```

5. Press **ENTER** and the printer displays

```
LAN Interface
Default Gateway
```

6. Press **ENTER** to display the current value.
7. Press **SCROLL/MICRO↑** or **SCROLL/MICRO↓** until the desired value for Default Gateway is displayed.
8. Press **ENTER**.
An asterisk (*) will be displayed in front of the selected value.
9. Press **START** or **RETURN** to exit the Menu. See “Exiting the Configuration Menu” on page 39.

Host Name

You can set the Host Name to:

- **14 Chars** (max)
- **4247_xxxxxx** (Default)

The host is identified by a name in the NetBios protocol over TCP/IP. This function allows you to create that host name using a 14-character string. The last 6-digits of the MAC address are *xxxxxx*.

To change or check the Host Name:

1. Press **MENU**.
2. Press **SCROLL/MICRO↑** or **SCROLL/MICRO↓** until the printer displays

```
CONFIGURATION MENU
ASCII Configuration
```

3. Press **ENTER**.
4. Press **SCROLL/MICRO↑** or **SCROLL/MICRO↓** until the printer displays

```
ASCII Configuration
LAN Interface
```

5. Press **ENTER** and the printer displays

```
LAN Interface
Host Name
```

6. Press **ENTER** to display the current value.
7. Press **SCROLL/MICRO↑** or **SCROLL/MICRO↓** until the desired value for Host Name is displayed.
8. Press **ENTER**.
An asterisk (*) will be displayed in front of the selected value.
9. Press **START** or **RETURN** to exit the Menu. See “Exiting the Configuration Menu” on page 39.

Workgroup Name

You can set the Workgroup Name to:

- **14 Chars** (max)
- **Workgroup** (Default)

The **Workgroup Name** allows the printer to be associated with another group of printers.

To change or check the **Workgroup Name**:

1. Press **MENU**.
2. Press **SCROLL/MICRO↑** or **SCROLL/MICRO↓** until the printer displays

```
CONFIGURATION MENU
ASCII Configuration
```

3. Press **ENTER**.
4. Press **SCROLL/MICRO↑** or **SCROLL/MICRO↓** until the printer displays

```
ASCII Configuration
LAN Interface
```

5. Press **ENTER** and the printer displays

```
LAN Interface
Workgroup Name
```

6. Press **ENTER** to display the current value.
7. Press **SCROLL/MICRO↑** or **SCROLL/MICRO↓** until the desired value for Workgroup Name is displayed.
8. Press **ENTER**.
An asterisk (*) will be displayed in front of the selected value.

9. Press **START** or **RETURN** to exit the Menu. See “Exiting the Configuration Menu” on page 39.

SMTP Service

SMTP (Simple Mail Transfer Protocol) allows a mail server address to be entered into the printer configuration to send automated e-mail notifications with printer alert conditions.

You can set the SMTP Service to:

- | | |
|---------------------------|--|
| Disabled (Default) | Disables the SMTP (Simple Mail Transfer Protocol) service (disables the reception/transfer/error service of the e-mail). |
| Enabled | Enables the SMTP service (enables the reception/transfer/error service of the e-mail). |

To change or check the SMTP Service:

1. Press **MENU**.
2. Press **SCROLL/MICRO↑** or **SCROLL/MICRO↓** until the printer displays

```
CONFIGURATION MENU
ASCII Configuration
```

3. Press **ENTER**.
4. Press **SCROLL/MICRO↑** or **SCROLL/MICRO↓** until the printer displays

```
ASCII Configuration
LAN Interface
```

5. Press **ENTER** and the printer displays

```
LAN Interface
SMTP Service
```

6. Press **ENTER** to display the current value.
7. Press **SCROLL/MICRO↑** or **SCROLL/MICRO↓** until the desired value for SMTP Service is displayed.
8. Press **ENTER**.
An asterisk (*) will be displayed in front of the selected value.
9. Press **START** or **RETURN** to exit the Menu. See “Exiting the Configuration Menu” on page 39.

Mail Server Address

You can set the Mail Server Address:
Example: **000.000.000.000** (Default)

These values set the Mail Server Address. This number is represented by a decimal notation. The decimal values are divided into four fields by periods. Each field's values can range from 0 to 255.

Note: You can only select Mail Server Address if the “SMTP Service” function choice is Enabled.

To change or check the Mail Server Address:

1. Press **MENU**.
2. Press **SCROLL/MICRO↑** or **SCROLL/MICRO↓** until the printer displays

```
CONFIGURATION MENU
ASCII Configuration
```

3. Press **ENTER**.
4. Press **SCROLL/MICRO↑** or **SCROLL/MICRO↓** until the printer displays

```
ASCII Configuration
LAN Interface
```

5. Press **ENTER** and the printer displays

```
LAN Interface
Mail Server Address
```

6. Press **ENTER** to display the current value.
7. Press **SCROLL/MICRO↑** or **SCROLL/MICRO↓** until the desired value for Mail Server Address is displayed.
8. Press **ENTER**.
An asterisk (*) will be displayed in front of the selected value.
9. Press **START** or **RETURN** to exit the Menu. See “Exiting the Configuration Menu” on page 39.

E-Mail Address (Receiver)

You can set the E-Mail Address (Receiver) to:

- **48 Chars** (max)
- **Null String** (Default)

This function allows you to enter the e-mail address (up to 48 characters in length) of the person you want to notify of printer failures.

Note: You can only select E-Mail Address (Receiver) if the “SMTP Service” function is Enabled.

To change or check the E-Mail Address (Receiver):

1. Press **MENU**.
2. Press **SCROLL/MICRO↑** or **SCROLL/MICRO↓** until the printer displays

```
CONFIGURATION MENU
ASCII Configuration
```

3. Press **ENTER**.
4. Press **SCROLL/MICRO↑** or **SCROLL/MICRO↓** until the printer displays

```
ASCII Configuration
LAN Interface
```

5. Press **ENTER** and the printer displays

```
LAN Interface
E-Mail Address (Receiver)
```

6. Press **ENTER** to display the current value.

7. Press **SCROLL/MICRO↑** or **SCROLL/MICRO↓** until the desired value for E-Mail Address (Receiver) is displayed.
8. Press **ENTER**.
An asterisk (*) will be displayed in front of the selected value.
9. Press **START** or **RETURN** to exit the Menu. See “Exiting the Configuration Menu” on page 39.

E-Mail Address (Sender)

You can set the E-Mail Address (Sender) to:

- **48 Chars** (max)
- **Null String** (Default)

This function allows you to enter the sender's e-mail address (up to 48 characters in length).

Note: You can only select E-Mail Address (Sender) if the “SMTP Service” function choice is Enabled.

To change or check the E-Mail Address (Sender):

1. Press **MENU**.
2. Press **SCROLL/MICRO↑** or **SCROLL/MICRO↓** until the printer displays

```
CONFIGURATION MENU
ASCII Configuration
```

3. Press **ENTER**.
4. Press **SCROLL/MICRO↑** or **SCROLL/MICRO↓** until the printer displays

```
ASCII Configuration
LAN Interface
```

5. Press **ENTER** and the printer displays

```
LAN Interface
E-Mail Address (Sender)
```

6. Press **ENTER** to display the current value.
7. Press **SCROLL/MICRO↑** or **SCROLL/MICRO↓** until the desired value for E-Mail Address (Sender) is displayed.
8. Press **ENTER**.
An asterisk (*) will be displayed in front of the selected value.
9. Press **START** or **RETURN** to exit the Menu. See “Exiting the Configuration Menu” on page 39.

Chapter 8. Printer setup

Paper Source	101	Automatic Eject	107
Front Forms Backup	102	Automatic Restore.	108
Rear Forms Backup	103	Continuous Forms Eject Mode.	109
Continuous Forms Linking	104	Bar Code Print Direction	110
Form Feed Mode	105	Graphics Print Direction	111
Controlling tear off operations.	106	Perforation Safety	112
Using automatic eject to control forms eject	106	Jam Sensors	113
Using automatic restore to control restoring of forms	106		

This chapter describes the procedures for checking and changing printer setup parameters for your 4247 printer. The chapter is divided into sections according to parameter. Refer to this partial table of contents for parameter and page listings.

Paper Source

The Paper Source parameter defines the current paper source for the printer. The values displayed on the operator panel depend on the forms devices installed in the printer. The paper source setting can be set to any of the following values:

- | | |
|------------------------|---|
| Front (Default) | The front paper path is assigned according to the forms tractors installed on the printer. The front paper path settings apply to the paper loaded with the tractor already installed on the printer, if the second (optional) tractor is not installed. If the second (optional) tractor is installed in the printer, the front paper path settings apply to the paper loaded on this second optional tractor. |
| Rear | The rear paper path settings apply to the paper loaded with the lower tractor, when the second (optional) tractor is installed on the printer. |

To change or check the Paper Source:

1. Press **MENU**.
2. Press **SCROLL/MICRO↑** or **SCROLL/MICRO↓** until the printer displays

```
CONFIGURATION MENU
Printer Setup
```

3. Press **ENTER**.
4. Press **SCROLL/MICRO↑** or **SCROLL/MICRO↓** until the printer displays

```
Printer Setup
Paper Source
```

5. Press **ENTER** to display the current value.
6. Press **SCROLL/MICRO↑** or **SCROLL/MICRO↓** until the desired value for paper source is displayed.
7. Press **ENTER**.
An asterisk (*) will be displayed in front of the selected value.
8. Press **START** or **RETURN** to exit the Menu. See “Exiting the Configuration Menu” on page 39.

Front Forms Backup

This setting applies to the paper loaded on the default tractor, if the second (optional) tractor is not installed. When the second optional tractor is installed, this setting applies to the paper loaded with this tractor. The Front Forms Backup parameter instructs the printer whether it can perform tractor movements that would back the forms up. Such movements include parking the printer. This would be used when the physical characteristics of the forms currently loaded make it undesirable for the printer to attempt to move the forms in the reverse direction (for example, labels).

Even if Front Forms Backup is disabled, the **SCROLL/MICRO** can still be used for the paper path. You can define the front forms backup to either one of the following values:

Enabled (Default)	Allows the printer to back up the front forms as needed.
Disabled	Prevents the printer from backing up front forms. Use this setting for labeled continuous forms.

To change or check the Front Forms Backup:

1. Press **MENU**.
2. Press **SCROLL/MICRO** or **SCROLL/MICRO** until the printer displays

```
CONFIGURATION MENU
Printer Setup
```

3. Press **ENTER**.
4. Press **SCROLL/MICRO** or **SCROLL/MICRO** until the printer displays

```
Printer Setup
Front Forms Backup
```

5. Press **ENTER** to display the current value.
6. Press **SCROLL/MICRO** or **SCROLL/MICRO** until the desired value for Front Forms Backup is displayed.
7. Press **ENTER**.
An asterisk (*) will be displayed in front of the selected value.
8. Press **START** or **RETURN** to exit the Menu. See "Exiting the Configuration Menu" on page 39.

Rear Forms Backup

This parameter is displayed as long as the second (optional) tractor is installed and applies to the paper loaded on the default (lower) tractor. The Rear Forms Backup parameter instructs the printer whether it can perform tractor movements that would back the forms up. Such movements include parking the printer. This would be used when the physical characteristics of the forms currently loaded make it undesirable for the printer to attempt to move the forms in the reverse direction (for example, labels).

Even if Rear Forms Backup is disabled, the **SCROLL/MICRO** can still be used for the paper path. You can define the rear forms backup to any one the following values:

Enabled (Default)	Allows the printer to back up the rear forms as needed.
Disabled	Prevents the printer from backing up rear forms.

To change or check the Rear Forms Backup:

1. Press **MENU**.
2. Press **SCROLL/MICRO** or **SCROLL/MICRO** until the printer displays

```
CONFIGURATION MENU
Printer Setup
```

3. Press **ENTER**.
4. Press **SCROLL/MICRO** or **SCROLL/MICRO** until the printer displays

```
Printer Setup
Rear Forms Backup
```

5. Press **ENTER** to display the current value.
6. Press **SCROLL/MICRO** or **SCROLL/MICRO** until the desired value for Rear Forms Backup is displayed.
7. Press **ENTER**.
An asterisk (*) will be displayed in front of the selected value.
8. Press **START** or **RETURN** to exit the Menu. See “Exiting the Configuration Menu” on page 39.

Continuous Forms Linking

This parameter is displayed only if the second (optional) tractor is also installed. Both Front Forms Backup and Rear Forms Backup must have the same values (either both enabled or disabled) for the continuous forms sources to be capable of being linked.

This parameter instructs the printer to automatically switch from the Front Push to Rear Push or Rear Push to Front Push paper paths when out of paper.

You can define continuous forms linking to one the following values:

Disabled (Default)	No linking is to be done.
Enabled	The Front Push and Rear Push continuous forms paths are to be linked together so they are treated by the printer as one continuous paper source.

To change or check the Continuous Forms Linking:

1. Press **MENU**.
2. Press **SCROLL/MICRO↑** or **SCROLL/MICRO↓** until the printer displays

```
CONFIGURATION MENU
Printer Setup
```

3. Press **ENTER**.
4. Press **SCROLL/MICRO↑** or **SCROLL/MICRO↓** until the printer displays

```
Printer Setup
Continuous Forms Linking
```

5. Press **ENTER** to display the current value.
6. Press **SCROLL/MICRO↑** or **SCROLL/MICRO↓** until the desired value for Continuous Forms Linking is displayed.
7. Press **ENTER**.
An asterisk (*) will be displayed in front of the selected value.
8. Press **START** or **RETURN** to exit the Menu. See "Exiting the Configuration Menu" on page 39.

Form Feed Mode

You can set Form Feed Mode to either of the following values:

- **Not Active In Ready State** (Default)
- **Active In Ready State**

Selecting Active in Ready State makes the **FORM FEED** key active when the printer is *ready* and no job is processing, so that when pressed, a form feed will be performed and the printer will return to the *ready* state.

The printer does not have to be *not ready* before pressing **FORM FEED** if you change the value to Active in the *ready* state.

To change or check the form feed mode:

1. Press **MENU**.
2. Press **SCROLL/MICRO↑** or **SCROLL/MICRO↓** until the printer displays

CONFIGURATION MENU Printer Setup

3. Press **ENTER**.
4. Press **SCROLL/MICRO↑** or **SCROLL/MICRO↓** until the printer displays

Printer Setup Form Feed Mode

5. Press **ENTER** to display the current value.
6. Press **SCROLL/MICRO↑** or **SCROLL/MICRO↓** until the desired value for form feed mode is displayed.
7. Press **ENTER**.
An asterisk (*) will be displayed in front of the selected value.
8. Press **START** or **RETURN** to exit the Menu. See “Exiting the Configuration Menu” on page 39.

Controlling tear off operations

When a path switch is requested and the top-of-forms is at the print line, the Park operation will begin automatically. No user intervention is required. In all other cases, user intervention is required. The message '091 FANFOLD PARK...' or '092 FANFOLD EJECT...' appears on the operator panel display.

Using automatic eject to control forms eject

If Automatic Eject = Disabled, which is the default, you must press **LOAD/EJECT** to move the form up to the tear bar. This setting is recommended if you do not need to tear off each form as it is printed. Thus, when you determine that you need to tear off the forms, you use **LOAD/EJECT** to control the tear off operations.

If Automatic Eject = Enabled, once printing finishes the printer will wait 5 seconds then automatically move the forms up to the tear bar. This setting is recommended if you plan to tear off each form as it finishes printing. This eliminates the need to press **LOAD/EJECT** for tear off operations.

Once the forms have been ejected, the next step depends of the setting of the Automatic Restore parameter.

The settings for Automatic Eject and Automatic Restore are used to control how you want tear off operations to occur. There is only one setting in the printer configuration for Automatic Eject and one setting for Automatic Restore which apply to both the front and rear continuous forms paths. The paths cannot be controlled individually.

Using automatic restore to control restoring of forms

After the forms have been ejected, message '003 FORMS EJECTED' is displayed. How the restore is handled depends on the setting of Automatic Restore. If user intervention is needed, information will be displayed in the second line of the '003 FORMS EJECTED' message.

If Automatic Restore = Disabled, the forms will not be restored to the print line until the **LOAD/EJECT** key is pressed. Message '003 FORMS EJECTED' will be displayed with 'PRESS LOAD' displayed in the second line to guide you.

In the following two options for Automatic Restore, the automatic restore function is being enabled. Since the forms will be restored without user intervention, the '003 FORMS EJECTED' message is just informational and will be displayed with a blank second line.

If Automatic Restore = Timer xx Seconds, the form will remain at the tear bar for the specified number of seconds then the printer will automatically restore the forms back down to the print line. When the next job is received printing will start.

If Automatic Restore = Data, once the form is at the tear bar it will remain there until the next job is received by the printer at which time the printer will automatically restore the forms back down to the print line and resume printing.

See the following tables for recommendations for Auto Eject and Auto Restore for single-path and dual path uses.

Table 14. Single Path Usage recommendations

Operation	No. Users	Tear Off	Auto Eject	Auto Restore
Single Path	1	On Demand	Disabled	Data or Timer
Single Path	1	Constant	Enabled	Data or Timer
Single Path	2 or more	On Demand	Disabled	Timer
Single Path	2 or more	Constant	Enabled	Timer

Note: The combination of settings with Automatic Eject = Enabled and Automatic Restore = Disabled is not recommended.

Table 15. Dual Path Usage recommendations

Operation	No. Users	Tear Off	Auto Eject	Auto Restore
Dual Push	1	On Demand	Disabled	Data
Dual Push	1	Constant	Enabled	Data
Dual Push	2 or more	On Demand	Disabled	Data
Dual Push	2 or more	Constant	Enabled	Data

Note: The combination of settings with Automatic Eject = Enabled and Automatic Restore = Disabled is not recommended.

Automatic Eject

This parameter is displayed for the Front Push or Rear Push forms path. You can set the printer to perform an automatic eject without pressing **LOAD/EJECT** when a print job is complete.

You can set this value to:

- Enabled** When the print job is complete, the printer will perform an automatic eject after a fixed timeout of approximately 5 seconds.
- Disabled (Default)** No automatic eject. The **LOAD/EJECT** is required to eject the forms.

To change or check the automatic eject after timeout, follow these steps:

1. Press **MENU**.
2. Press **SCROLL/MICRO↑** or **SCROLL/MICRO↓** until the printer displays

```
CONFIGURATION MENU
Printer Setup
```

3. Press **ENTER**.
4. Press **SCROLL/MICRO↑** or **SCROLL/MICRO↓** until the printer displays

```
Printer Setup
Automatic Eject
```

5. Press **ENTER** to display the current value.
6. Press **SCROLL/MICRO↑** or **SCROLL/MICRO↓** until the desired value for the Automatic Eject is displayed.
7. Press **ENTER**.
An asterisk (*) will be displayed in front of the selected value.

8. Press **START** or **RETURN** to exit the Menu. See “Exiting the Configuration Menu” on page 39.

Automatic Restore

This parameter is displayed for the Front Push or Rear Push forms path. You can set the printer to perform an automatic load without pressing **LOAD/EJECT**.

You can set this value to:

Disabled (Default)	No automatic load. The LOAD/EJECT is required to load forms.
Data	An automatic load occurs each time a new print job is received.
Timer (10 to 50 seconds)	An automatic load with a fixed timeout value. When forms are ejected, a load function is performed after a timeout. The timeout value can be 10 seconds, 20 seconds, 30 seconds, 40 seconds, or 50 seconds.

To change or check the automatic restore, follow these steps:

1. Press **MENU**.
2. Press **SCROLL/MICRO↑** or **SCROLL/MICRO↓** until the printer displays

```
CONFIGURATION MENU
Printer Setup
```

3. Press **ENTER**.
4. Press **SCROLL/MICRO↑** or **SCROLL/MICRO↓** until the printer displays

```
Printer Setup
Automatic Restore
```

5. Press **ENTER** to display the current value.
6. Press **SCROLL/MICRO↑** or **SCROLL/MICRO↓** until the desired value for Automatic Restore is displayed.
7. Press **ENTER**.
An asterisk (*) will be displayed in front of the selected value.
8. Press **START** or **RETURN** to exit the Menu. See “Exiting the Configuration Menu” on page 39.

The Automatic Restore function can be enabled regardless of the status of the Automatic Eject function. Automatic Restore can be enabled even if Automatic Eject is not enabled.

Continuous Forms Eject Mode

You can set Continuous Forms Eject Mode value to:

- **Immediate Eject** (Default)
- **Delayed Eject**

Selecting Delayed Eject causes the printer to wait until the end of the current page is reached before forms are moved to the tear off position. For more information, see “LOAD/EJECT” on page 33.

To change or check Continuous Forms Eject Mode:

1. Press **MENU**.
2. Press **SCROLL/MICRO↑** or **SCROLL/MICRO↓** until the printer displays

CONFIGURATION MENU Printer Setup

3. Press **ENTER**.
4. Press **SCROLL/MICRO↑** or **SCROLL/MICRO↓** until the printer displays

Printer Setup Forms Eject Mode

5. Press **ENTER** to display the current value.
6. Press **SCROLL/MICRO↑** or **SCROLL/MICRO↓** until the desired value for Continuous Forms Eject Mode is displayed.
7. Press **ENTER**.
An asterisk (*) will be displayed in front of the selected value.
8. Press **START** or **RETURN** to exit the Menu. See “Exiting the Configuration Menu” on page 39.

Bar Code Print Direction

You can set the Bar Code Print Direction to:

Unidirectional

Causes the printer to print in only one direction, either from left to right or from right to left, for each of the two passes of bar code printing on a line.

Bidirectional (Default)

Causes the printer to print as the printhead moves in both directions. (This setting causes faster throughput but may affect print quality. Verify that the print quality is acceptable before running a print job.)

To change or check the bar code print direction, follow these steps:

1. Press **MENU**.
2. Press **SCROLL/MICRO↑** or **SCROLL/MICRO↓** until the printer displays

```
CONFIGURATION MENU
Printer Setup
```

3. Press **ENTER**.
4. Press **SCROLL/MICRO↑** or **SCROLL/MICRO↓** until the printer displays

```
Printer Setup
Bar Code Print Direction
```

5. Press **ENTER** to display the current value.
6. Press **SCROLL/MICRO↑** or **SCROLL/MICRO↓** until the desired value for bar code print direction is displayed.
7. Press **ENTER**.
An asterisk (*) will be displayed in front of the selected value.
8. Press **START** or **RETURN** to exit the Menu. See “Exiting the Configuration Menu” on page 39.

Graphics Print Direction

You can set the Graphics Print Direction to:

Unidirectional

Causes the printer to print in only one direction, either from left to right or from right to left, for each of the two passes of graphics printing on a line.

Bidirectional (Default)

Causes the printer to print as the printhead moves in both directions. (This setting causes faster throughput but may affect print quality. Verify that the print quality is acceptable before running a print job.)

To change or check the graphics print direction, follow these steps:

1. Press **MENU**.
2. Press **SCROLL/MICRO↑** or **SCROLL/MICRO↓** until the printer displays

```
CONFIGURATION MENU
Printer Setup
```

3. Press **ENTER**.
4. Press **SCROLL/MICRO↑** or **SCROLL/MICRO↓** until the printer displays

```
Printer Setup
Graphics Print Direction
```

5. Press **ENTER** to display the current value.
6. Press **SCROLL/MICRO↑** or **SCROLL/MICRO↓** until the desired value for graphics print direction is displayed.
7. Press **ENTER**.
An asterisk (*) will be displayed in front of the selected value.
8. Press **START** or **RETURN** to exit the Menu. See “Exiting the Configuration Menu” on page 39.

Perforation Safety

You can set perforation safety to either of the following values:

Disabled (Default)

The printhead is not parked all the way to the right of the print line while the perforation of the form is passing through the mylar opening.

Enabled

The printhead is parked all the way to the right of the print line so that the perforation of the form can advance through the mylar without the printhead touching the form.

Note: This setting is recommended for thick multiple-part forms.

To change or check the Perforation Safety value:

1. Press **MENU**.
2. Press **SCROLL/MICRO↑** or **SCROLL/MICRO↓** until the printer displays

```
CONFIGURATION MENU
Printer Setup
```

3. Press **ENTER**.
4. Press **SCROLL/MICRO↑** or **SCROLL/MICRO↓** until the printer displays

```
Printer Setup
Perforation Safety
```

5. Press **ENTER** to display the current value.
6. Press **SCROLL/MICRO↑** or **SCROLL/MICRO↓** until the desired value for perforation safety is displayed.
7. Press **ENTER**.
An asterisk (*) will be displayed in front of the selected value.
8. Press **START** or **RETURN** to exit the Menu. See "Exiting the Configuration Menu" on page 39.

Jam Sensors

You can set Jam Sensors to either of the following values:

Enabled (Default)	Enables the paper jam sensors on the front and rear tractors. This setting alerts the operator with an 002 FORMS JAMMED FRONT or 020 FORMS JAMMED REAR message on the operator panel when a jammed form is detected in one of the paper paths.
Disabled	Disables the paper jam sensors. We recommend that these sensors not be disabled.

To change or check the Jam Sensors category:

1. Press **MENU**.
2. Press **SCROLL/MICRO↑** or **SCROLL/MICRO↓** until the printer displays

```
CONFIGURATION MENU
Printer Setup
```

3. Press **ENTER**.
4. Press **SCROLL/MICRO↑** or **SCROLL/MICRO↓** until the printer displays

```
Printer Setup
Jam Sensors
```

5. Press **ENTER** to display the current value.
6. Press **SCROLL/MICRO↑** or **SCROLL/MICRO↓** until the desired value for jam sensors is displayed.
7. Press **ENTER**.
An asterisk (*) will be displayed in front of the selected value.
8. Press **START** or **RETURN** to exit the Menu. See “Exiting the Configuration Menu” on page 39.

Chapter 9. Printer adjustments

Paper-Load-Position to Tear-Position relationship	115	Rear Tear Position	118
Front Automatic Forms Thickness Adjustment (AFTA)	116	Rear Left Margin Alignment	119
Front Tear Position	116	Rear Paper Load Position	120
Front Left Margin Alignment	117	Bidirectional Adjustment	120
Front Paper Load Position	117	Sensor Tune	121
Rear Automatic Forms Thickness Adjustment (AFTA)	118	Quit From Menu	121

This chapter describes the procedures for checking and changing the Printer Adjustment parameters. The Printer Adjustments appear in both the Configuration Menu and in the Operator Print Tests Menu. In the Configuration Menu, the values can be set but not tested. In the Operator Print Tests, the adjustments can be set and then tried by running a print test. (See Chapter 17, “Using the Operator Print Tests.”) Printer adjustment parameters can be set for each paper source: Front and Rear.

This chapter is divided into sections according to parameter. Refer to the partial table of contents above for parameter and page listings.

Paper-Load-Position to Tear-Position relationship

There are Paper Load Position parameters for each forms path. These Paper Load Position settings are used to vertically align printing on the forms. An example is to center printing in a box on a preprinted form.

Whenever one of these Paper Load Position parameters is set, the printer automatically adjusts the corresponding Tear Position value to compensate for the change you made to the Load Position. This automatic adjustment keeps the forms perforation aligned to the tear bar edge when the form is ejected. However, if further adjustment is needed in the alignment of the forms perforation to the tear bar, you should adjust the Tear Position value.

The automatic adjustment changes the tear adjustment by the same number of units but in the opposite direction. Normally this adjustment means that Tear Position is set to the offsetting (“equal but opposite”) value. Stated another way, if the Load Position is set to +40, then the Tear Position is set to -40 (see example 1 in the examples that follow). However, if the current setting of the Tear Position has been changed by the operator to be different from the offsetting value, that difference from the offsetting value is maintained by the printer (see example 2 in the examples that follow).

Examples of how this works:

1. The current values in the printer are Front Paper Load Position = 0 and Front Tear Position = 0. The user sets Front Paper Load Position to +40. The printer automatically sets Front Tear Position to -40.
2. The current values in the printer are Front Paper Load Position = +40 and Front Tear Position = -44. The user changes Front Paper Load Position to +50. The printer automatically sets Front Tear Position to -54, maintaining the difference of 4 from the normal offsetting value of “equal but opposite”.

Front Automatic Forms Thickness Adjustment (AFTA)

This parameter allows you to adjust the distance between the paper and the printhead for the front forms path. Forms must be loaded for this adjustment to be effective. This adjustment can be set to one of the following values:

-5 to +3 The printer automatically adjusts the distance between the forms and the printhead. Each adjustment corresponds to 0.03 mm (.0012 in.). (The default is 0, which corresponds to a gap of 0.25 mm [.01 in.] from the forms.)

Fixed 1 to 8 Selects a fixed printhead distance value from 1 to 8, in increments of 0.5 (where each value equals approximately 0.05 mm [.002 in.]).

Default = 0

To change or check the Front AFTA:

1. Press **MENU**.
2. Press **SCROLL/MICRO↑** or **SCROLL/MICRO↓** until the printer displays

```
CONFIGURATION MENU
Printer Adjustments
```

3. Press **ENTER**.
4. Press **SCROLL/MICRO↑** or **SCROLL/MICRO↓** until the printer displays

```
Printer Adjustments
Front AFTA
```

5. Press **ENTER** to display the current value.
6. Press **SCROLL/MICRO↑** or **SCROLL/MICRO↓** until the desired value for front AFTA is displayed.
7. Press **ENTER**.
An asterisk (*) will be displayed in front of the selected value.
8. Press **START** or **RETURN** to exit the Menu. See "Exiting the Configuration Menu" on page 39.

Front Tear Position

You can adjust the front tear position for forms loaded in the front forms path from -390 to +30 (where each unit is 0.176 mm [1/144 in.]). The default value is 0.

To change or check the Front Tear position:

1. Press **MENU**.
2. Press **SCROLL/MICRO↑** or **SCROLL/MICRO↓** until the printer displays

```
CONFIGURATION MENU
Printer Adjustments
```

3. Press **ENTER**.
4. Press **SCROLL/MICRO↑** or **SCROLL/MICRO↓** until the printer displays

```
Printer Adjustments
Front Tear Position
```

5. Press **ENTER** to display the current value.

6. Press **SCROLL/MICRO**↑ or **SCROLL/MICRO**↓ until the desired value for Front Tear Position is displayed.
7. Press **ENTER**.
An asterisk (*) will be displayed in front of the selected value.
8. Press **START** or **RETURN** to exit the Menu. See “Exiting the Configuration Menu” on page 39.

Front Left Margin Alignment

This parameter adjusts the distance of the first print position to the left margin from 0 to 60 units (where each unit is 0.706 mm [1/36 in.]). The default is 0 units. The total range of adjustment is 42.36 mm (1.66 in.).

To change or check the Front Left Margin Alignment:

1. Press **MENU**.
2. Press **SCROLL/MICRO**↑ or **SCROLL/MICRO**↓ until the printer displays

```
CONFIGURATION MENU
Printer Adjustments
```

3. Press **ENTER**.
4. Press **SCROLL/MICRO**↑ or **SCROLL/MICRO**↓ until the printer displays

```
Printer Adjustments
Front Left Margin Align
```

5. Press **ENTER** to display the current value.
6. Press **SCROLL/MICRO**↑ or **SCROLL/MICRO**↓ until the desired value for Front Left Margin Align is displayed.
7. Press **ENTER**.
An asterisk (*) will be displayed in front of the selected value.
8. Press **START** or **RETURN** to exit the Menu. See “Exiting the Configuration Menu” on page 39.

Note: If the left margin alignment is too large for the current print line, an 005 MARGIN ERROR ADJ MARGIN OR LINE LENGTH will occur. For more information on the message, see Chapter 19, “Problem solving.”

Front Paper Load Position

This parameter adjusts the distance of the first printable line to the top of the paper from -30 to +360 units (2 in.) (where each unit is 0.176 mm [1/144 in.]). The default value is 0.

To change or check the Front Paper Load Position:

1. Press **MENU**.
2. Press **SCROLL/MICRO**↑ or **SCROLL/MICRO**↓ until the printer displays

```
CONFIGURATION MENU
Printer Adjustments
```

3. Press **ENTER**.
4. Press **SCROLL/MICRO**↑ or **SCROLL/MICRO**↓ until the printer displays

Printer Adjustments
Front Form Load Position

5. Press **ENTER** to display the current value.
6. Press **SCROLL/MICRO↑** or **SCROLL/MICRO↓** until the desired value for Front Paper Load Position is displayed.
7. Press **ENTER**.
An asterisk (*) is displayed in front of the selected value.
8. Press **START** or **RETURN** to exit the Menu. See “Exiting the Configuration Menu” on page 39.

Rear Automatic Forms Thickness Adjustment (AFTA)

This parameter allows you to adjust the distance between the paper and the printhead for the rear forms path. Forms must be loaded for this adjustment to be effective. This adjustment can be set to one of the following values:

- 5 to +3** The printer automatically adjusts the distance between the forms and the printhead. Each adjustment corresponds to 0.03 mm (.0012 in.). (The default is 0, which corresponds to a gap of 0.25 mm [.01 in.] from the forms.)
- Fixed 1 to 8** Selects a fixed printhead distance value from 1 to 8 in increments of 0.5 (where each value equals approximately 0.05 mm [.002 in.]).

Default = 0

To change or check the Rear AFTA:

1. Press **MENU**.
2. Press **SCROLL/MICRO↑** or **SCROLL/MICRO↓** until the printer displays

CONFIGURATION MENU
Printer Adjustments

3. Press **ENTER**.
4. Press **SCROLL/MICRO↑** or **SCROLL/MICRO↓** until the printer displays

Printer Adjustments
Rear AFTA

5. Press **ENTER** to display the current value.
6. Press **SCROLL/MICRO↑** or **SCROLL/MICRO↓** until the desired value for Rear AFTA is displayed.
7. Press **ENTER**.
An asterisk (*) will be displayed in front of the selected value.
8. Press **START** or **RETURN** to exit the Menu. See “Exiting the Configuration Menu” on page 39.

Rear Tear Position

You can adjust the rear tear position for forms loaded in the rear paper path from -390 to +30 (where each unit is 0.176 mm [1/144 in.]). The default value is 0.

To change or check the Rear Tear Position:

1. Press **MENU**.

2. Press **SCROLL/MICRO↑** or **SCROLL/MICRO↓** until the printer displays

```
CONFIGURATION MENU
Printer Adjustments
```

3. Press **ENTER**.
4. Press **SCROLL/MICRO↑** or **SCROLL/MICRO↓** until the printer displays

```
Printer Adjustments
Rear Tear Position
```

5. Press **ENTER** to display the current value.
6. Press **SCROLL/MICRO↑** or **SCROLL/MICRO↓** until the desired value for Rear Tear Position is displayed.
7. Press **ENTER**.
An asterisk (*) will be displayed in front of the selected value.
8. Press **START** or **RETURN** to exit the Menu. See “Exiting the Configuration Menu” on page 39.

Rear Left Margin Alignment

This parameter adjusts the distance of the first print position to the left margin from 0 to 60 units (where each unit is 0.706 mm [1/36 in.]). The default is 0 units. The total range of adjustment is 42.36 mm (1.66 in.).

To change or check the Rear Left Margin Align:

1. Press **MENU**.
2. Press **SCROLL/MICRO↑** or **SCROLL/MICRO↓** until the printer displays

```
CONFIGURATION MENU
Printer Adjustments
```

3. Press **ENTER**.
4. Press **SCROLL/MICRO↑** or **SCROLL/MICRO↓** until the printer displays

```
Printer Adjustments
Rear Left Margin Align
```

5. Press **ENTER** to display the current value.
6. Press **SCROLL/MICRO↑** or **SCROLL/MICRO↓** until the desired value for Rear Left Margin Align is displayed.
7. Press **ENTER**.
An asterisk (*) will be displayed in front of the selected value.
8. Press **START** or **RETURN** to exit the Menu. See “Exiting the Configuration Menu” on page 39.

Note: If the left margin alignment is too large for the current print line, an 005 MARGIN ERROR ADJ MARGIN/LINE LENGTH will occur. For more information on the message, see Chapter 19, “Problem solving,” on page 151.

Rear Paper Load Position

This parameter adjusts the distance of the first printable line to the top of the paper from -30 to +360 units (2 in.) (where each unit is 0.176 mm [1/144 in.]). The default value is 0.

To change or check the Rear Paper Load Position:

1. Press **MENU**.
2. Press **SCROLL/MICRO↑** or **SCROLL/MICRO↓** until the printer displays

```
CONFIGURATION MENU
Printer Adjustments
```

3. Press **ENTER**.
4. Press **SCROLL/MICRO↑** or **SCROLL/MICRO↓** until the printer displays

```
Printer Adjustments
Rear Form Load Position
```

5. Press **ENTER** to display the current value.
6. Press **SCROLL/MICRO↑** or **SCROLL/MICRO↓** until the desired value for Rear Paper Load Position is displayed.
7. Press **ENTER**.
An asterisk (*) will be displayed in front of the selected value.
8. Press **START** or **RETURN** to exit the Menu. See “Exiting the Configuration Menu” on page 39.

Bidirectional Adjustment

You can adjust dot registration and print quality for characters on your printer by running the bidirectional adjustment test pattern. The test pattern consists of three parts: two groups of *H*'s (four lines each) with the current alignment value above them and a line of *H*'s and *I*'s printed on one line. You can set bidirectional adjustment from -6 to 6 (where each unit is 0.212 mm [1/120 in.]). The default value is 0.

Note: Bidirectional Adjustment is available only in the Operator Print Tests menu.

To change or check the bidirectional adjustment:

1. Press **Test**.
2. Press **SCROLL/MICRO↑** or **SCROLL/MICRO↓** until the printer displays

```
OPERATOR PRINT TESTS
Printer Adjustments
```

3. Press **ENTER**.
4. Press **SCROLL/MICRO↑** or **SCROLL/MICRO↓** until the printer displays

```
Printer Adjustments
Bidirectional Adjustment
```

5. Press **ENTER** to display the current value.
6. Press **SCROLL/MICRO↑** or **SCROLL/MICRO↓** until the desired value for Bidirectional Adjustment is displayed.

7. Press **ENTER**.
An asterisk (*) will be displayed in front of the selected value.
8. Press **START** or **RETURN** to exit the Menu. See “Exiting the Configuration Menu” on page 39.

Sensor Tune

This parameter establishes the black light threshold levels for all sensors. This adjustment is initially set when the printer is manufactured and may have to be adjusted for long-term aging of the sensor if false form jams occur or if unusual ambient lighting conditions exist in the printer location.

Important: All paper must be removed from the tractors and all covers must be installed and closed before selecting this parameter.

Note: Sensor Tune is available only in the Operator Print Tests menu.

To tune the sensors:

1. Press **TEST**.
2. Press **SCROLL/MICRO↑** or **SCROLL/MICRO↓** until the printer displays

```
OPERATOR PRINT TESTS
Printer Adjustments
```

3. Press **ENTER**.
4. Press **SCROLL/MICRO↑** or **SCROLL/MICRO↓** until the printer displays

```
Printer Adjustments
Sensor Tune
```

5. Press **ENTER**. The printer displays the following:

```
Sensor Tune
Remove Forms Press ENTER
```

6. Press **ENTER**. The printer will now tune the sensors. Once the sensors are tuned, the printer displays

```
Sensor Tune
Sensor Tune Complete
```

```
Printer Adjustments
Sensor Tune
```

7. Press **START** or **RETURN** to exit the Menu. See “Exiting the Configuration Menu” on page 39.

Quit From Menu

This selection cancels any changes that have been made to the Printer Adjustment parameter values in the Operator Print Test menu. All previous printer adjustment values are restored when this parameter is selected and the printer enters the *Not Ready* state.

Note: Quit From Menu is available only in the Operator Print Tests menu.

To quit from the Operator Print Test menu and restore the previous values for Printer Adjustments only, follow these steps:

1. Press **SCROLL/MICRO** or **SCROLL/MICRO** until the printer displays

Printer Adjustments Quit from Menu

2. Press **ENTER**. The printer displays

Quit from Menu Restore Previous Values

3. Press **ENTER**. The printer restores the previous values and becomes *not ready*.

Chapter 10. Power-On Reset (POR)

Note: When power-on reset is activated, the printer performs a partial reset.

To perform a power-on reset, follow these steps:

1. Press **MENU**.
2. Press **SCROLL/MICRO↑** or **SCROLL/MICRO↓** until the printer displays

CONFIGURATION MENU Power On Reset

3. Press **ENTER**.

The printer displays

Power On Reset Yes

4. Press **ENTER**.

The printer displays

Power On Reset Reset Executed

5. Press **START** or **RETURN** to exit the Menu. See “Exiting the Configuration Menu” on page 39.

Chapter 11. Display Language

The following languages are available for displaying messages on the operator panel:

Table 16. Display Languages

Language	Value
English (Default)	000
Deutsch	001
Français	002
Italiano	003
Español	004
Nederlands	005
Dansk	006
Português	007
Norsk	008
Svenska	009
Suomi	010
Polski	011

Note: The display language changes immediately when you select a new value.

To change or check the display language, follow these steps:

1. Press **MENU**.
2. Press **SCROLL/MICRO** or **SCROLL/MICRO** until the printer displays

CONFIGURATION MENU Display Language
--

3. Press **ENTER**.
4. Press **SCROLL/MICRO** or **SCROLL/MICRO** until the desired value for display language is displayed.
5. Press **ENTER**.

An asterisk (*) will be displayed in front of the selected value, and the display language will change.

6. Press **START** or **RETURN** to exit the Menu. See “Exiting the Configuration Menu” on page 39.

Note: Occasionally the display language may be changed accidentally to a language that is not understood. To recover to your native language without saving the display language in a custom set, power off (O) and then power on (I) the printer to restore the default setting. The display language should then be restored to your native language.

Chapter 12. Vital Product Data

You can check and change some of the vital product data for the printer. The two Vital Product Data fields you can change are:

- Serial Number
- Device Specific Information

Note: Vital Product Data values, unlike all of the other configuration values, are not saved when you save a custom set; they are saved when you exit the Configuration Menu. If you make a change to one of these values and turn off the printer before exiting the Configuration Menu, your changes will not be saved.

Serial Number

The serial number parameter holds the serial number for the printer. This number is a 7-digit alphanumeric value. The serial number of your printer is located on the *Information Label* on the back of printer and next to the power-on switch.

To check or change the serial number for the printer, follow these steps:

1. Press **MENU**.
2. Press **SCROLL/MICRO** or **SCROLL/MICRO** until the printer displays

```
CONFIGURATION MENU
Vital Product Data
```

3. Press **ENTER**.
4. Press **SCROLL/MICRO** or **SCROLL/MICRO** until the printer displays

```
Vital Product Data
Serial Number
```

5. Press **ENTER**.
The printer displays the current value for the serial number of the printer. A cursor (X) appears under the least significant character of the value.
6. Press **SCROLL/MICRO** or **SCROLL/MICRO** to change the character above the cursor.
7. Press **ENTER** to move the cursor to the next character.
8. Repeat steps 6 and 7 until the correct value for the serial number is displayed.
9. Press **START** or **RETURN** to exit the Menu. See “Exiting the Configuration Menu” on page 39.

Device Specific Information

This parameter stores user defined information for the printer. This information is a 16-digit alphanumeric value.

To check or change the Device Specific Information for the printer, follow these steps:

1. Press **MENU**.
2. Press **SCROLL/MICRO↑** or **SCROLL/MICRO↓** until the printer displays

```
CONFIGURATION MENU
Vital Product Data
```

3. Press **ENTER**.
4. Press **SCROLL/MICRO↑** or **SCROLL/MICRO↓** until the printer displays

```
Vital Product Data
Device Specific Info
```

5. Press **ENTER**.
The printer displays the current value for device specific information. A cursor (X) appears under the least significant character of the value.
6. Press **SCROLL/MICRO↑** or **SCROLL/MICRO↓** to change the character above the cursor.
7. Press **ENTER** to move the cursor to the next character.
8. Repeat steps 6 and 7 until you have checked or changed the Device Specific Information.
9. Press **START** or **RETURN** to exit the Menu. See "Exiting the Configuration Menu" on page 39.

Chapter 13. Quiet Print

You can enable the **Quiet Print** mode to reduce the printing noise level by two to three decibels. Enabling the **Quiet Print** mode also reduces the printer's throughput by one half. The default is **No = (Disabled)**. To enable or disable the **Quiet Print** mode:

1. Press the **MENU** key.
2. Press **SCROLL/MICRO↑** or **SCROLL/MICRO↓** to select the **Quiet Print**.

CONFIGURATION MENU Quiet Print

3. Press the **ENTER** key.
4. Press **SCROLL/MICRO↑** or **SCROLL/MICRO↓** to select **Yes** or **No** to enable or disable the **Quiet Print** mode.
5. Press the **ENTER** key.
6. Press the **START** key.

Chapter 14. Hex Print

The **Hex Print** function is only valid when the printer is in the *not ready* state. Use the **Hex Print** function to print all data in Hexadecimal format. The default is **No = (Disabled)**. To enable or disable the **Hex Print** function:

1. Press the **MENU** key.
2. Press **SCROLL/MICRO↑** or **SCROLL/MICRO↓** to select **Hex Print**.

CONFIGURATION MENU Hex Print

3. Press the **ENTER** key.
4. Press **SCROLL/MICRO↑** or **SCROLL/MICRO↓** to select **Yes** or **No** to enable or disable the **Hex Print** function.
5. Press the **ENTER** key.
6. Press the **START** key.

Chapter 15. Quit From Menu

You can quit from the Configuration Menu and restore the previous configuration menu values.

This selection cancels any changes you made to the Configuration Menu Parameter Values since you last pressed **MENU** to enter the Configuration Menu.

To quit from the Configuration Menu and restore the previous values, follow these steps:

1. If CONFIGURATION MENU is not on the first line of the display, press **RETURN** until it appears.
2. Press **SCROLL/MICRO↑** or **SCROLL/MICRO↓** until the printer displays

```
CONFIGURATION MENU
Quit from Menu
```

3. Press **ENTER**. The printer displays

```
Quit from Menu
Restore Previous Values
```

4. Press **ENTER**. The printer restores the previous values and becomes *not ready*.

Note: Any custom set changes that were made and saved prior to selecting Quit From Menu are not affected by this selection. The new values stored into custom sets remain in place.

Chapter 16. Dual push tractor forms paths

Introduction	135	Using same forms on both paths (linking)	137
Forms selection.	135	Setting up printer	137
Using different forms on two paths	136	How forms linking works	138
Setting up printer	136	Parking one continuous form and loading another	138
Using path switching.	136	Parking a continuous form	138
Data stream control of path switching	136	Changing the forms path	138
Operator panel control of path switching	137		

Introduction

This chapter contains step-by-step procedures for each paper feeding method.

The 4247 printer can be set up to simultaneously process forms through two push paths, the front push and the rear push. This is called dual push.

There are two ways of using this configuration. The first way is to load the two paths with different forms. The printer can be set up to support two different applications and the printing can be switched between the two forms. See “Using different forms on two paths” on page 136 for more information.

The second way is to load the two paths with the same form. For some specific applications, such as printing reports overnight without running out of forms, you may find using the same form in both paths to be a good solution. The printer can be set up to automatically switch paper sources and keep printing.

Notes:

1. The 4247 Printer can print on various sizes, dimensions, and weights of forms. We recommend that you test all forms for your application before ordering large quantities.
2. We recommend that you test the Park function when you intend to run multiple-part forms. If you notice problems with backing up the forms, try using the Eject function.
3. When your printer is loaded with different forms in the front push and the rear push tractors, your job (or the operator) can select the desired source, and alternate between the two paths. The operator must tear off the forms to allow the printer to change paths.
4. Your printer comes with one forms tractor already installed on the printer. When only this tractor is installed, the settings for the front paper path apply to the paper loaded on this tractor. If instead the second (optional) tractor is installed in the printer, the settings for the front path apply to the paper loaded with the upper tractor, whereas the default tractor becomes the rear tractor.

Forms selection

You might select a forms path based on specific operating needs, frequency of use, and ease of replenishing forms. Other times the forms path you should use is dictated by the type of forms you are printing, such as black-back forms which can only be used on the optional second tractor.

Using different forms on two paths

Setting up printer

Some setup is needed to be able to print on two different form types.

1. Place "form-type-1" on the front tractor pins and "form-type-2" on the rear tractor pins. Do not load the forms up to the print line.
2. Ensure that Continuous Forms Linking = Disabled is set in the Printer Setup section of the Configuration Menu. Disabled is the default value for this setting.
3. Also in the Printer Setup section of the Configuration Menu, set Automatic Eject and Automatic Restore to the values you want, based on the information and descriptions, including the recommended usage tables, in "Controlling tear off operations" on page 106.

Using path switching

The path switching can be controlled either at the operator panel or by the data stream. In either method, manual intervention will be required to tear off the current form if the forms are past the print area when the path switching is initiated. If forms are not past the print area when the path switching is initiated, the path switch will start automatically.

Note: If you are running IPDS applications, such as PSE, path switching is always controlled by the IPDS data stream. Operator panel control of the path switching is not available with these applications.

If the 4247 is being shared by more than one user, data stream controlled switching will probably work best since the timing of operator panel controlled switching with the arrival of the job can get complicated.

Data stream control of path switching

With data stream control of the path switching, some actions are taken by the printer based on the data stream commands received and some based on operator panel keys being pressed.

The following description assumes that the Backup parameter in the Printer Setup section of the Configuration Menu is enabled for the current forms path.

When a path selection command is received at the printer that requires the printer to switch paths, and forms need to be torn off, the message '091 FANFOLD PARK...' will be displayed on the operator panel display. From that point, perform the following:

1. The forms will already have been ejected, so tear off the forms at the form perforation at the tear bar.
2. Press **PARK/PATH** to confirm to the printer that it can proceed with the park operation. The printer will park the forms on the current path then automatically switch to the other path and print the job.

Note: When a path selection command is received at the printer that requires the printer to switch paths, and forms do not need to be torn off, the printer will automatically park the forms on the current path then switch to the other path and print the job.

Operator panel control of path switching

Note: If you are running IPDS applications, such as PSF, path switching is always controlled by the IPDS data stream. Operator panel control of the path switching is not available with these applications. For SCS applications, you may need to enable the Override Host function of the printer in order for the operator panel control of path switching to work.

With operator panel control of the path switching, most actions are taken by the printer only on command from the user pressing keys at the operator panel. Setting Automatic Restore to Disabled is recommended for the most complete operator panel control of path switching.

1. If forms need to be torn off:

The first step you must take depends on the setting for Automatic Eject. See “Using automatic eject to control forms eject” on page 106 for more information on these settings.

If Automatic Eject = Disabled (infrequent need for tear off), press **LOAD/EJECT**. The printer will eject the current forms to the tear bar. Tear off the forms at the perforation at the tear bar. Message ‘003 FORMS EJECTED / PRESS LOAD’ will be displayed on the operator panel.

If Automatic Eject = Enabled (frequent need for tear off), the printer will wait 5 seconds after finishing printing before automatically ejecting the forms. After the printer ejects the forms to the tear bar, message ‘003 FORMS EJECTED’ will be displayed on the operator panel. Tear the forms at the perforation at the tear bar.

After having torn the forms, the path switching procedure is the same regardless of the setting of Automatic Eject. The rest of the steps follow:

- a. Press **LOAD/EJECT**. The printer will restore the forms back to the print line.
 - b. Press **PARK/PATH**. The printer will park the forms on the current path.
 - c. Press **PARK/PATH** as many times as needed until the path you want to select is indicated by the message in the middle of the second line of the operator panel display. automatically
 - d. Press the **START** key to make the printer ready for the next job. The forms will be automatically loaded by the printer when the next job is received. Or you can press **LOAD/EJECT** to manually load the forms on the new path then press **START** to make the printer ready for the next job.
2. If forms do not need to be torn off:
- a. Press **PARK/PATH**. The printer will park the forms on the current path.
 - b. Press **PARK/PATH** as many times as needed until the path you want to select is indicated by the message in the middle of the second line of the operator panel display. automatically
 - c. Press **START** to make the printer ready for the next job. The forms will be automatically loaded by the printer when the next job is received. Or you can press **LOAD/EJECT** to manually load the forms on the new path then press **START** to make the printer ready for the next job.

Using same forms on both paths (linking)

Setting up printer

Some setup is needed to use the printer in this way. Perform the following steps.

1. Place the same forms on both front and rear tractors. Place the forms onto the tractor pins. Do not load the forms up to the print line.

2. Set Continuous Forms Linking = Enabled in the Printer Setup section of the Configuration Menu. This tells the printer to automatically switch to the second push path when the first reaches end-of-forms.
3. If the job does not contain the forms path selection commands, use the **PARK/PATH** key, select either Front or Rear as the current path.
4. Press **START** to make the printer Ready.
5. Send your job to the printer.

How forms linking works

When the printer reaches end-of-forms on the current path, it automatically will switch to the second continuous forms path and perform a load operation. If forms are mounted on the tractor pins, printing will continue. If left completely unattended, the printer will print using the second box of forms until either the job is finished or the end-of-forms is reached for the second forms source. The '001 END OF FORMS' message will only be displayed on the operator panel when both of the continuous forms paths are empty.

While the printer is printing on the second path, you could again load forms onto the pins of the first tractor. If you do this, the printer will again switch automatically when it reaches end-of-forms. You can continue doing this indefinitely. As long as forms are loaded on the pins of the other tractor, the printer will automatically switch to that tractor when the current tractor reaches end-of-forms. The '001 END OF FORMS' message will only be displayed on the operator panel when both of the continuous forms paths are empty.

Parking one continuous form and loading another

The 4247 printer can have two continuous forms loaded at the same time. The topics below explain how you can take advantage of this feature and free yourself from having to reload forms when you need to print on a different form.

Parking a continuous form

1. Press **PARK/PATH**. If forms are currently loaded from the Front Push or Rear Push forms paths, the printer displays:

<p>091 FANFOLD PARK TEAR OUTPUT PRESS PARK</p>
--

Or if forms are loaded in the Front Push forms path with **FRONT FORMS BACKUP** set to **DISABLED** or in the Rear Push forms path with **REAR FORMS BACKUP** set to **DISABLED**, the printer displays:

<p>092 FANFOLD EJECT TEAR INPUT PRESS EJECT</p>

2. Press **STOP** and perform the action requested on the operator panel display.
3. Press **PARK/PATH** to back the forms below the print line or press **LOAD/EJECT** to eject the last sheet.

Changing the forms path

Select another continuous form as follows:

1. Ensure that a form is in the tractors of the desired alternate forms path.
2. Press **PARK/PATH** again to change the forms path on the operator panel display to the desired alternate forms path.

Chapter 17. Using the Operator Print Tests

General test instructions	139	Print Custom Sets	141
Quick Reference	140	Firmware Information	142
Printer Demonstration	140	Printer Adjustments	142
Printer Configuration.	141		

This chapter describes the print tests you can perform to:

- Check information on the operator panel keys and the configuration menu.
- Demonstrate printer capabilities
- Check the version code level of your printer
- Check your printer configuration values
- Change and check printer adjustments for each forms path.

Any of these tests can be performed at anytime. However, all tests should be performed when there is no print data buffered and the printer is not processing data. When you use the Operator Print Tests, the printer goes *offline*. When you exit test mode, the printer performs a *partial reset* before going back *online*. This partial reset clears any buffered print data and anything stored in printer storage.

Entering the Operator Print Tests may cause the forms configuration values to be adjusted. If the current values are less than a maximum print position of 72 or a maximum page length of 66, the printer will adjust the values. This is done to ensure correct formatting of all offline customer tests. A form that is at least 210 mm x 297 mm (8.27 x 11.70 in.) is needed to run any of the operator print tests. The original values will be reset when the printer returns to the online state. If the values are larger than the required page dimensions, the values are not changed.

General test instructions

To enter the Operator Print Tests menu, press **STOP** to make the printer *not ready*. Press **TEST**. The printer displays



The Quick Reference test is the first test in the Operator Print Tests menu. From this display, press **SCROLL/MICRO↑** or **SCROLL/MICRO↓** to view the other tests. Pressing **ENTER** or **START** begins a test.

While a test is running, pressing **STOP** or **CANCEL PRINT** halts the test. If you press **STOP**, the test is halted and you are still in the Operator Print Tests menu. If you press **CANCEL PRINT**, the printer exits test mode, performs a partial reset, and becomes online *ready*.

When a test is not running, pressing **RETURN** or **CANCEL PRINT** tells the printer to exit test mode and perform a partial reset. If you press **RETURN**, the printer becomes *not ready*. If you press **CANCEL PRINT**, the printer becomes online *ready*.

Quick Reference

The Quick Reference is a popular print test to help familiarize you with the printer operator panel keys and the configuration menu you can set. Each key is shown with a corresponding description to the right. Each parameter is also shown with the corresponding values you can select printed to the right. It does not indicate the default values. See the “Configuration Categories” in Chapter 3, “Checking and changing configuration parameter values” for the default values.

The information is printed in the currently selected display language and it matches the method of attachment for your printer.

To begin the Quick Reference Test:

1. Press **STOP** to make the printer *not ready*.
2. Press **TEST**.

The printer displays

OPERATOR PRINT TESTS Quick Reference

3. Press **ENTER** or **START** to begin the test. The **READY** indicator goes on and printing begins.
4. When the Quick Reference test is complete the **READY** indicator goes off.
5. Press **CANCEL PRINT** to make the printer *ready* or **RETURN** to make the printer *not ready* (see “General test instructions” on page 139).

Printer Demonstration

You can print samples of all the available print qualities and bar codes by using the Printer Demonstration test.

Note: The 4247 Printer can perform this test without being connected to a computer. This test will only print in the English language.

To begin the printer demonstration:

1. Press **STOP** to make the printer *not ready*.
2. Press **TEST**.
3. Press **SCROLL/MICRO↑** or **SCROLL/MICRO↓** until the printer displays

OPERATOR PRINT TESTS Printer Demonstration

4. Press **ENTER** or **START** to begin the test. The **READY** indicator goes on and printing begins.
5. When the Printer Demonstration test is complete the **READY** indicator goes off.
6. Press **CANCEL PRINT** to make the printer *ready* or **RETURN** to make the printer *not ready* (see “General test instructions” on page 139).

Printer Configuration

You can print the current values for each parameter. Here are some considerations:

- Each parameter is shown with its corresponding value printed to the right.
- The category and parameter names are printed in the current display language used on the operator panel.
- The current custom set is noted at the top right column of the configuration printout.
- If you need to verify each custom set, the Operator Print Tests must be run for each custom set.
- The custom set must be changed in the configuration menu before running each configuration printout, see Recall Custom Set values.
- A flag (****) is printed after each parameter value that is different from the factory default value.

Printer configurations can be checked by entering the configuration menu.

To print the printer configuration:

1. Press **STOP** to make the printer *not ready*.
2. Press **TEST**.
3. Press **SCROLL/MICRO**↑ or **SCROLL/MICRO**↓ until the printer displays

OPERATOR PRINT TESTS Printer Configuration

4. Press **ENTER** or **START** to begin the test.

The **READY** indicator goes on and printing begins. The printout shows the current configuration. The configuration printout is complete when the **READY** indicator goes off.

5. Press **CANCEL PRINT** to make the printer *ready* or **RETURN** to make the printer *not ready* (see “General test instructions” on page 139).

Print Custom Sets

Use this function to create a printout of the eight custom set values.

On the first page of the printout, each custom set is identified as either In Use or as Factory Defaults.

- | | |
|-------------------------|---|
| In Use | At least one value in the custom set is different from the factory default value. A flag (****) is printed after each parameter value that is different from the factory default. |
| Factory Defaults | A custom set that is identical to one of the factory defaults. |

If a custom set is identical to the factory defaults, it will be identified as Factory Defaults. If the only change from factory defaults is a non-custom set parameter value (a value that stays the same no matter which custom set you are using), only the first custom set will be identified as In Use. The other custom sets will be shown as factory defaults.

To print the custom sets:

1. Press **STOP** to make the printer *not ready*.

2. Press **TEST**.
3. Press **SCROLL/MICRO↑** or **SCROLL/MICRO↓** until the printer displays

```
OPERATOR PRINT TESTS
Print Custom Sets
```

4. Use **ENTER** or **START** to begin the test. The printout will list all the custom sets.
The Ready indicator is lighted and the Print Test prints. The printout is complete when the Ready indicator is no longer lighted.
5. Press **CANCEL PRINT** to make the printer *ready*, or **RETURN** to make the printer *not ready*.

Firmware Information

You can print information to verify your printer model number and the microcode level installed in your printer. You will need this information if problems occur with your printer and you need to contact your service representative.

To check the Firmware Information:

1. Press **STOP** to make the printer *not ready*.
2. Press **TEST**.
3. Press **SCROLL/MICRO↑** or **SCROLL/MICRO↓** until the printer displays

```
OPERATOR PRINT TESTS
Firmware Information
```

4. Press **ENTER** or **START** to begin the test.
The **READY** indicator goes on and printing begins. The firmware printout is complete when the **READY** indicator goes off.
5. Press **CANCEL PRINT** to make the printer *ready* or **RETURN** to make the printer *not ready* (see "General test instructions" on page 139).

Printer Adjustments

You can make adjustments to your printer to maintain print quality. The adjustments can be set and then tested by running a print test without having to exit the menu. There is a set of printer adjustment parameters for each forms path: Front or Rear. Chapter 9, "Printer adjustments" describes the procedures for checking and changing the values of the printer adjustments. The following are the available printer adjustment parameters:

- Front Automatic Forms Thickness Adjustment (AFTA)
- Front Tear Position
- Front Left Margin Alignment
- Front Paper Load Position
- Rear Automatic Forms Thickness Adjustment (AFTA)
- Rear Tear Position
- Rear Left Margin Alignment
- Rear Paper Load Position
- Bidirectional Adjustment (Available only in Operator Print Test Menu)
- Sensor Tune (Available only in Operator Print Test Menu)
- Quit From Menu (Available only in Operator Print Test Menu)

To check or change printer adjustments:

1. Press **STOP** to make the printer *not ready*.
2. Press **TEST**.
3. Press **SCROLL/MICRO** or **SCROLL/MICRO** until the printer displays

OPERATOR PRINT TESTS Printer Adjustments

4. Press **ENTER**.
5. Press **SCROLL/MICRO** or **SCROLL/MICRO** until the desired value for Printer Adjustments is displayed.
6. Press **ENTER** and change the values you wish to change.
7. Press **START** to run a print test for acceptable quality and alignment.
If the quality is not acceptable, return to Step 4, otherwise, continue.
8. Press **FORM FEED** to see what you printed.
9. Press **CANCEL PRINT** to make the printer *ready* or **RETURN** to make the printer *not ready* (see "General test instructions" on page 139).

Chapter 18. Supplies, optional features, and maintenance

Continuous forms specifications	145	Optional features	148
Proper forms loading.	146	Maintenance.	149
Forms Handling Paper Paths	147	Removing the ribbon cartridge	149
Forms stacking recommendations	147	Cleaning the printer	149
Forms stack input and output locations	147	Cleaning inside the printer	150
Supplies	148	Cleaning the covers	150

Continuous forms specifications

The 4247 Model X03 operates with continuous forms. All forms should be evaluated in the printer's functional environment for forms handling, print registration, and print quality acceptability prior to use. The forms must meet the following specifications:

Paper Criteria	Characteristics	Continuous Forms
		Front Push, Rear Push
Dimensions	Width	76.2 to 431.8 mm 3 to 17 in.
	Length	76.2 to 609.6 mm 3 to 24 in.
Single Part	Weight	55 to 150 g/m ² 15 to 40 lb
	Thickness	0.08 to 0.635 mm 0.003 to 0.025 in.
Multiple Part	Maximum parts (Original + Copies)	1 + 7 chemical 1 + 5 carbon paper
	Overall Thickness	0.08 to 0.635 mm 0.003 to 0.025 in.
	Weight of top part	55 to 150 g/m ² 15 to 40 lb
	Attached sheet individual weight	45 to 75 g/m ² 12 to 20 lb
	Carbon paper individual weight	14 to 35 g/m ² 4 to 9 lb

Notes:

1. Test forms less than 152.4 mm (6 in.) in length or width for satisfactory stacking. These forms may require additional operator attention.
2. For optimum performance, restrict the printable area to be within 6.4 mm (0.25 in.) from all edges, holes, or folds on the forms.

3. Some multiple-part forms (such as mailers, thick/heavy perforations) may cause problems when using the Park function. Try the forms first. To minimize parking problems, discuss your needs with your forms supplier when selecting forms.
4. We do not recommend continuous forms with adhesive labels.
5. To prevent the separation of labels from continuous-forms when using the **EJECT** or **PARK** keys, set **FRONT FORMS BACKUP=DISABLED** or **REAR FORMS BACKUP=DISABLED** in the Power On Configuration menu. Making this configuration change does the following:
 - Disables the **EJECT** key tear-off function
 - Modifies how the **PARK** key works for forms in the Front Push and Rear Push forms paths. You cannot back up the forms to park them. Break the forms at a perforation before they enter the printer. Press **PARK** twice, and the forms will move forward until ejected from the printer.
6. Black-back forms cannot be used in the default tractor. They can only be used in the optional second tractor.

Proper forms loading

The paper must be loaded as shown in Figure 35.

Note: The input forms must always be lower than the printer.

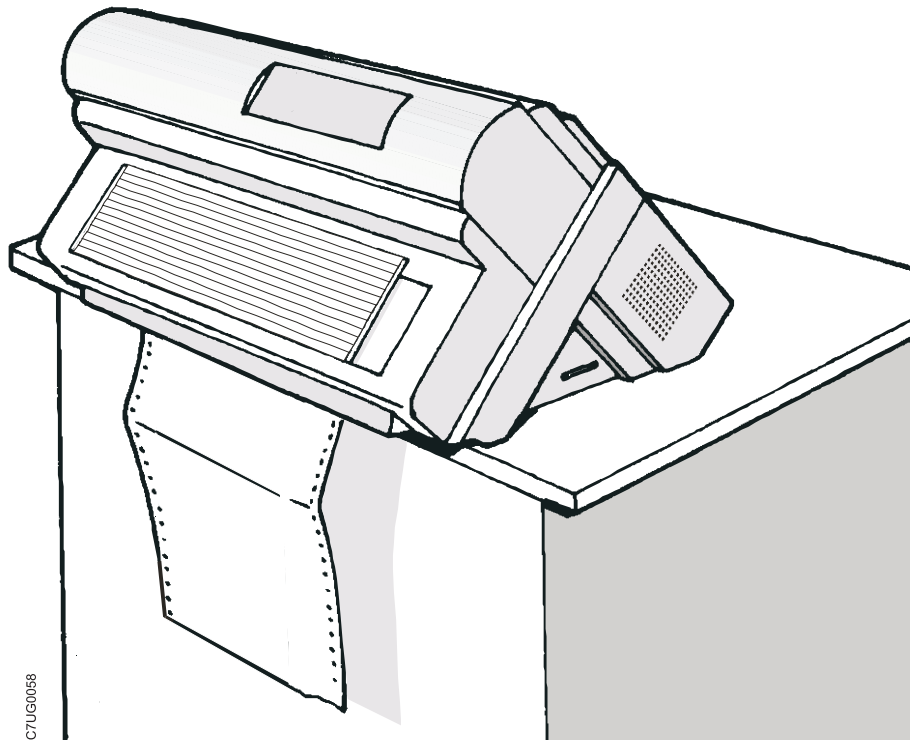

Figure 35. Correctly Loaded Paper

We offer an optional printer stand for your 4247 Printer. For more information on this printer stand, contact your marketing representative.

Note: For optimum performance, We recommend using the Front Push forms path.

Forms Handling Paper Paths

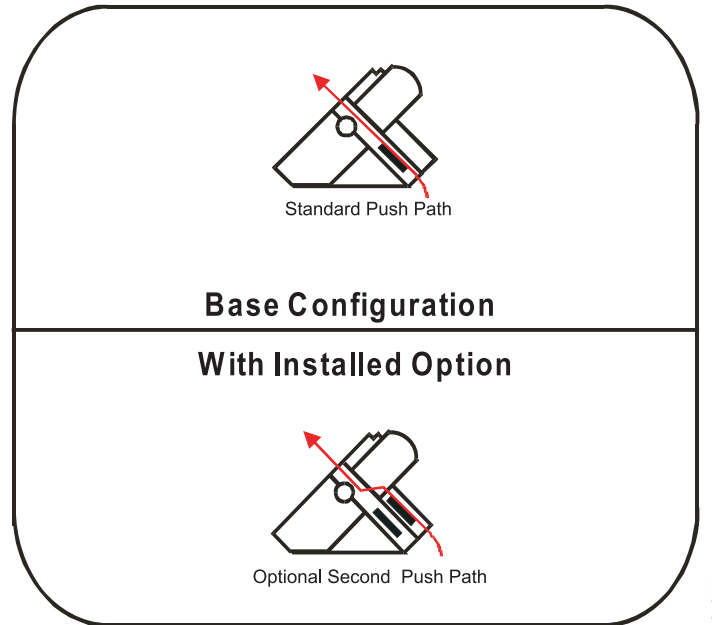

Figure 36. Forms Handling Paper Paths

Forms stacking recommendations

We recommend the following maximum stacking height when stacking continuous forms on the same work surface as the printer.

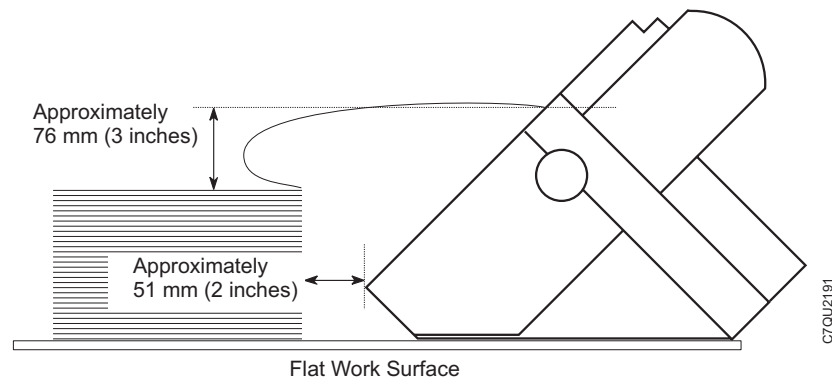

Figure 37. Forms stacking recommendations

Forms stack input and output locations

Depending on which forms path you are using, see the diagrams on the following pages for ways to stack input and output forms for your printer.

For satisfactory stacking results, the distance from the printer stand to the floor should be 736 to 762 mm (29 to 30 in.) and the distance between the shelf and the floor should be 381 mm (15 in.). We offer an optional printer stand for your 4247 Printer. For more information on this printer stand, contact your marketing representative.

Note: For successful forms parking, the input forms stack MUST always be lower than the printer.

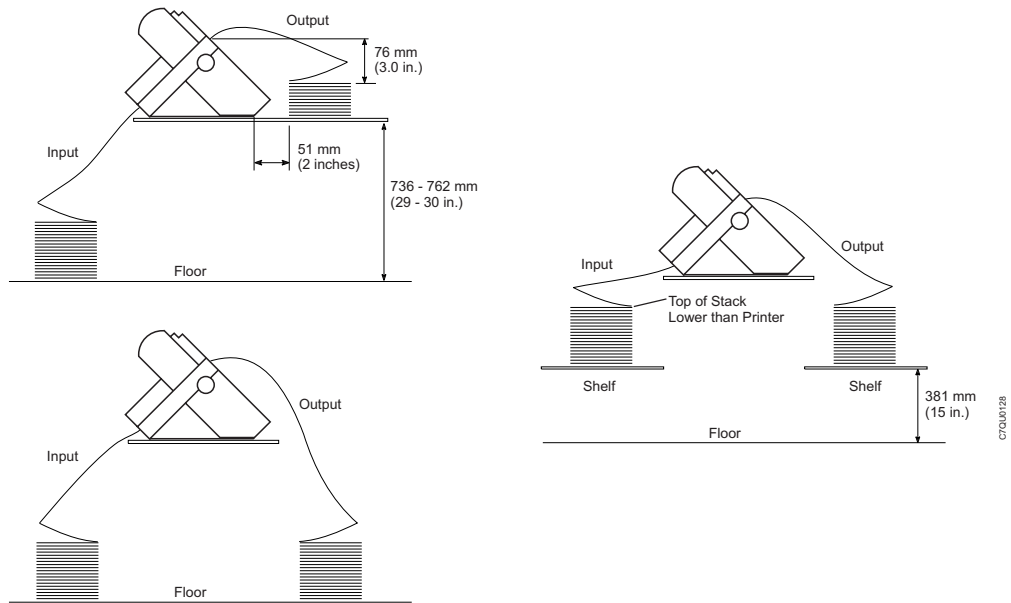

Figure 38. Forms stacking recommendations

Supplies

Ribbon cartridges and paper are the only supplies you need for your printer. Use Part Number 57P1743 when ordering a replacement ribbon cartridge.

Optional features

Option	Description
Printer Stand	An optional stand provides input and output shelves for handling fanfold paper.
Second forms tractor	An optional second tractor can be installed. In this way it is possible to handle two different types of fanfold paper simultaneously with the printer.
Controller Board	There are three Controller Board options: <ol style="list-style-type: none"> 1. Allows a host connection to parallel, serial, and USB 2.0 interfaces. 2. Allows a host connection to parallel and ASCII Ethernet 10/100 BaseT LAN interfaces. 3. Allows a host connection to parallel and ASCII-IPDS Ethernet 10/100 BaseT LAN interfaces

For more information on these optional features, contact your marketing representative.

Maintenance

Removing the ribbon cartridge

Attention: Damage to the printer can occur if you do not use an approved ribbon (part number 57P1743) especially designed for the 4247 Model X03 printer.



CAUTION:

<2-25> High temperature; switch off the printer and allow at least 20 minutes for parts in this area to cool before handling.

To remove an existing ribbon cartridge, follow these steps:

1. Open the printer top cover.
2. Slide the printhead to the center of the printer.
3. Slide the ribbon guide out of the printhead.
4. Free the shifter holder by pushing the tab towards the rear and pulling the shifter holder up.

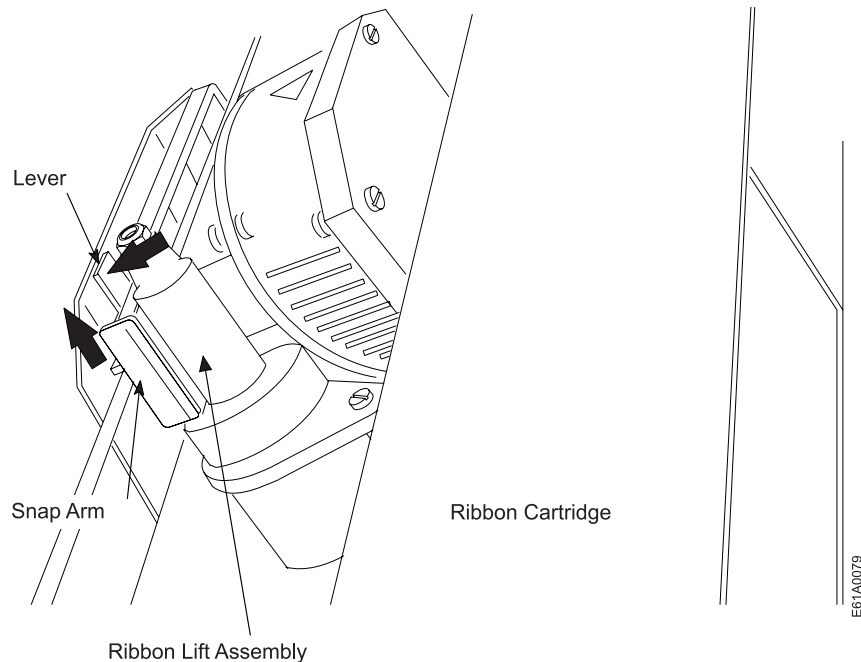

Figure 39. Freeing the shifter holder

5. Now you are ready to insert the new ribbon cartridge (see “Installing the ribbon cartridge” on page 9).

Cleaning the printer



CAUTION:

<2-25> High temperature; switch off the printer and allow at least 20 minutes for parts in this area to cool before handling.



CAUTION:

<2-22> Carefully follow all cleaning instructions, using only the materials and solutions recommended.

Periodic cleaning will help keep your printer in top condition so that it will always provide optimal performance.

Before you clean the printer:

1. Power off (O) the printer.
2. Unplug the power cord.
3. Wait at least 15 minutes for the printhead to cool before starting this procedure.

Cleaning inside the printer

Every few months, use a soft brush and a vacuum cleaner to remove dust, ribbon lint, and pieces of paper. Remove the ribbon cartridge to prevent the ribbon from going into the vacuum cleaner. Vacuum any dust from around the printhead and in the printer cavity.

Attention: Do not allow any staples, paper clips, or small metal pieces to fall inside the printer.

Cleaning the covers

Clean the outside of the printer with a damp cloth and mild soap. Do not use any spray-type or chemical cleaners anywhere on your printer. Do not put any liquids or spray near the air vents. For stubborn ink stains on the cover, use a commercial mechanic's hand cleaner.

Do not use an abrasive cloth, alcohol, paint thinner, or similar agents because they may cause discoloration or scratching.

Chapter 19. Problem solving

Using status code and problem listings	151	Forms problems	159
Status code and messages displays	151	Print quality and ribbon problems	160
No status code displays	151	Configuration problems	162
Status codes and recovery actions	152	Miscellaneous problems	162
Problem list index	156	Clearing forms jams	163

When the printer displays a status code, you need to know what action to take to recover from the displayed condition. This chapter lists the status codes and recovery actions and gives a list of problems, probable causes, and recovery actions for problems that do not display a status code. As with any problem, if you can not correct the situation after performing the recovery action, call or service.

Using status code and problem listings

When a problem with the printer occurs, the printer displays a status code and message. The message on the display identifies the problem and gives a recommended action.

Status code and messages displays

Find the code listed in numeric order on the following pages and perform the steps to fix the problem. Only codes on which an operator can take action are included.

Note: If you get a code that you cannot find in this section, record the code and run the job again. If you get the same code, call for service.

No status code displays

Scan the “Problem list index” on page 156 and go to the page listed beside the problem. Find your problem in the chart, read down the page to the “Solution” and perform the recommended recovery action. If you still cannot correct the situation, turn off the printer, wait 10 seconds, and turn on the printer. If the problem persists, call for service

Status codes and recovery actions

Display Message	Recovery Action
<p>001 END OF FORMS LOAD FORMS</p> <p>An end-of-forms condition exists in one of the forms paths.</p>	<p>Action 1</p> <ol style="list-style-type: none"> 1. Press STOP to silence the alarm. 2. Load forms in the appropriate forms path. 3. Press LOAD/EJECT. 4. Press START. <p>Action 2</p> <p>If the message displays again, verify that the left hand edge of the form is not aligned past the 22nd spacer on the printer cabinet. Adjust the form so that it is further to the left inside the 22nd spacer on the printer base (see "Loading forms in the Front Push Tractors" on page 16).</p> <p>Action 3</p> <p>If the message displays again, remove the forms and tune the paper presence sensor. See "Sensor Tune" in Chapter 9, "Printer adjustments," on page 115.</p>
<p>002 FORMS JAMMED FRONT CLEAR JAM RELOAD FORMS</p>	<ol style="list-style-type: none"> 1. Press STOP to silence the alarm. The message remains in the display. 2. Clear the jammed or torn form. If the paper is difficult to remove from the printhead area, rotate the AFTA wheel (located on the left side under the ribbon cartridge) to a higher number to clear the jam. 3. Reload forms onto the tractor. 4. Close the top cover. 5. Press LOAD/EJECT to load forms. 6. Press START to restart the print job. <p>If the message displays again, perform the actions under "Forms buckle, twist, jam, or tractor holes tear" on page 159.</p>
<p>003 FORMS EJECTED PRESS LOAD</p>	<p>Auto Restore is set to Disabled and an Eject has moved the form up to the Tear Bar. The printer is waiting. This is most likely to occur during a tear off operation. Tear the forms at the perforation at the Tear Bar. Then a manual Restore must be done by pressing LOAD/EJECT.</p> <p>If the Processing light is blinking, the next job has already been received and is pending.</p>
<p>003 FORMS EJECTED</p>	<p>Auto Restore is set to Data or Timer and an Eject has moved the form up to the Tear Bar. The printer will restore the form automatically either when the next job is received (Auto Restore = Data) or after a defined time elapses (Auto Restore = Timer).</p>
<p>005 MARGIN ERROR ADJ MARGIN/LINE LENGTH</p>	<ol style="list-style-type: none"> 1. Press STOP. The left margin automatically resets to 10 units (see Chapter 9, "Printer adjustments," on page 115). 2. Press START.
<p>009 INVALID KEY PRESS 009 INVALID KEY PRESSES 009 INVALID KEY PRESS PRESS STOP FIRST</p>	<ol style="list-style-type: none"> 1. Check the operator panel function. 2. Reenter the correct operation. <p>See Chapter 3, "Checking and changing configuration parameter values," on page 37.</p>

Display Message	Recovery Action
<p>014 INVALID FORMS SELECT ADD PATH OR PRESS START</p> <p>014 XXXXXXXX ADD PATH OR PRESS START</p> <p>The device requested by the job being sent is not installed in the printer. The above messages alternate at one second intervals where XXXXXXXX tells the requested forms device which can be Front or Rear.</p>	<ol style="list-style-type: none"> 1. To print the job with the requested paper source: <ol style="list-style-type: none"> a. Turn off the printer. b. Install the desired forms device. c. Turn on the printer. d. Resubmit the print job. 2. To cancel the job now and resubmit the job later with the correct device installed: <ol style="list-style-type: none"> a. Press STOP. b. Press CANCEL PRINT. 3. To print the job with an available paper source: <ol style="list-style-type: none"> a. Press STOP. b. Press PARK/PATH. c. Select an available forms path. d. Press START. 4. To print the job with the current paper source: <ol style="list-style-type: none"> a. Press STOP. b. Press START.
<p>020 FORMS JAMMED REAR CLEAR JAM RELOAD FORMS</p>	<ol style="list-style-type: none"> 1. Press STOP to silence the alarm. The message remains in the display. 2. Clear the jammed or torn form. If paper is difficult to remove from the printhead area, note the setting on the AFTA wheel, rotate the AFTA wheel to a higher number to clear the jam, and return the AFTA wheel to the original setting. 3. Reload forms onto the tractor. 4. Close the top cover. 5. Press LOAD/EJECT to load forms. 6. Press START to restart the job. 7. If the message displays again, perform the actions under "Forms buckle, twist, jam, or tear."
<p>026 HEX PRINT ACTIVE</p>	<ol style="list-style-type: none"> 1. Press START. <p>All data will print in hexadecimal code until you press STOP.</p>
<p>050 MACHINE CHECK X Y Z SEE USER'S GUIDE</p> <p>051 MACHINE CHECK X Y Z SEE USER'S GUIDE</p> <p>052 MACHINE CHECK X Y Z SEE USER'S GUIDE</p> <p>053 MACHINE CHECK X Y Z SEE USER'S GUIDE</p> <p>054 MACHINE CHECK SEE USER'S GUIDE</p> <p>055 MACHINE CHECK SEE USER'S GUIDE</p> <p>056 MACHINE CHECK SEE USER'S GUIDE</p> <p>An unrecoverable error has occurred. Record the error information X, Y, Z.</p>	<ol style="list-style-type: none"> 1. Turn off the printer. 2. Wait 10 seconds, then turn on the printer. 3. If the printer displays this status code again, call for service.

Display Message	Recovery Action
<p>059 CANCEL PRINT ACTIVE</p> <p>This an informational message. The printer displays this message after you press CANCEL PRINT.</p>	<ol style="list-style-type: none"> 1. Press START to cancel the current print job or press CANCEL PRINT again (before pressing START) to return the printer to READY. (The print job will not be cancelled.)
<p>068 DATA CLEARED PRESS STOP THEN START</p>	<ol style="list-style-type: none"> 1. Press STOP. 2. Press START.
<p>070 PRINTER BOARD CHANGE VERIFY MENU SETTINGS</p> <p>Configuration and custom sets values may have been lost when the printer board was modified.</p>	<ol style="list-style-type: none"> 1. Press STOP. 2. Press MENU. 3. Verify the configuration values and custom sets. (See Chapter 3, "Checking and changing configuration parameter values," on page 37 and "Custom sets" on page 49 "Custom sets".) 4. Press START or RETURN to exit the menu. If the printer displays this status code again, call for service..
<p>086 PRINTER BOARD CHANGE VERIFY MENU SETTINGS</p>	<ol style="list-style-type: none"> 1. Turn the power off. 2. Ensure the Small Rear Cover is securely installed. See Figure 1 on page 2. 3. Turn the power on.
<p>088 INVALID PAPER SOURCE USE FRONT OR CHANGE MENU</p> <p>Incorrect Power On Paper Source selected in configuration. Change the configuration to an available paper source.</p>	<ol style="list-style-type: none"> 1. Press STOP. 2. See "Attaching the 4247 Printer to your computer" on page 25.
<p>089 RIBBON JAM CHECK RIBBON</p>	<ol style="list-style-type: none"> 1. Turn off the printer. 2. Remove the ribbon cartridge. 3. Turn the ribbon advance knob to be sure that the ribbon is advancing correctly. If the ribbon does not advance correctly, replace the ribbon cartridge. 4. Reinstall the ribbon (see "Installing the ribbon cartridge" on page 9). 5. Turn on the printer. 6. If the printer this status code again, call for service.
<p>091 FANFOLD PARK TEAR OUTPUT PRESS PARK</p>	<ol style="list-style-type: none"> 1. Tear off the forms at the perforation before entry into the printer. 2. Press LOAD/EJECT.
<p>092 FANFOLD EJECT TEAR INPUT PRESS EJECT</p>	<ol style="list-style-type: none"> 1. Tear off the forms at the perforation. 2. Press PARK/PATH.
<p>093 EJECT PENDING</p>	<p>This is an informational message. The printer displays this message after you press LOAD/EJECT to eject the forms when Continuous Forms Eject Mode is set to Delayed Eject (see "Printer setup" on page 45). The printer displays 003 FORMS EJECTED/PRESS LOAD after the forms are ejected.</p>
<p>095 OPTION NOT AVAILABLE CHANGE PRINT LANGUAGE</p>	<ol style="list-style-type: none"> 1. Press STOP. 2. Change the Print Language value in the Configuration Menu category to something other than OCR-A or OCR-B.
<p>096 NOT READY COVER OPEN</p>	<ol style="list-style-type: none"> 1. Close the printer top cover. 2. Press START to make the printer READY.
<p>097 FUNCTION DISABLED MENU LOCKED</p> <p>This message is displayed when Menu is pressed when the Menu Lock feature is enabled.</p>	<p>Contact your system programmer.</p>

Display Message	Recovery Action
<p>099 FORMS JAMMED CLEAR JAM PRESS START</p> <p>The printer has detected paper in one of the paper paths. This often occurs if you press PARK/PATH before tearing off the forms.</p>	<p>This detection of unexpected forms was done by one of these paper presence sensors located near the platen:</p> <ul style="list-style-type: none"> • Front forms path • Rear forms path • If you had just pressed LOAD/EJECT or were printing when printing unexpectedly stopped, proceed with <i>Corrective Action 1</i>. • If you had just pressed PARK/PATH with the 091 FANFOLD PARK... message, proceed with <i>Corrective Action 2</i>.
<p>099 FORMS JAMMED CLEAR JAM PRESS START</p> <p>The printer has detected paper in one of the paper paths. This often occurs if you press PARK/PATH before tearing off the forms.</p>	<p><i>Corrective Action 1</i></p> <p>An extra form, a torn piece of form, or paper chad is located in the forms path when there should be no paper present. Remove this paper to clear the 099 message.</p> <ol style="list-style-type: none"> 1. Remove the forms from the appropriate tractor. 2. Remove any pieces of paper, paper chad, or paper dust with puffs of blown air from the sensors located approximately 3 inches from the left end of the platen.
<p>099 FORMS JAMMED CLEAR JAM PRESS START</p> <p>The printer has detected paper in one of the paper paths. This often occurs if you press PARK/PATH before tearing off the forms.</p>	<p><i>Corrective Action 2</i></p> <p>099 message during a Park operation</p> <p>The Park operation, initiated with the PARK/PATH key and 091 FANFOLD PARK... message, requires that any fanfold forms above the tear bar be torn off before confirming the Park operation with a second press of PARK/PATH. Failure to tear off forms may result in the 099 message indicating that the forms have backed up a certain distance but were not detected as being back on the tractor.</p> <ol style="list-style-type: none"> 1. Press STOP once. The 099 message will change back to the 091 FANFOLD PARK... message. 2. Press STOP a second time. The 099 message remains on the display but the alarm will stop. 3. Open the top cover. 4. Tear off at any form perforation above the carriage or printhead. 5. Close the top cover. 6. Press PARK/PATH once. The park operation will restart. If the 099 message returns, the forms have been backed up a certain distance but the printer again did not detect that the forms are back on the tractor. Repeat the steps for <i>Corrective Action 2</i>. If the path has been successfully cleared, the forms will be parked.
<p>220 SERIAL DSR ERROR SEE USER'S GUIDE</p> <p>A remote connection serial interface error occurred.</p>	<ol style="list-style-type: none"> 1. Turn off the printer. 2. Ensure the interface cable is connected to the printer and to the modem. 3. Ensure the serial configuration parameters are set correctly (see "ASCII Configuration" on page 42). 4. Turn on the printer.
<p>221 SERIAL OVERFLOW SEE USER'S GUIDE</p> <p>A serial input buffer overflow error was detected. (Data has been lost.)</p>	<ol style="list-style-type: none"> 1. Press STOP to clear the message. 2. Compare the SERIAL PACING PROTOCOL value that is set in the printer to the pacing protocol of the host system (see "Pacing Control" on page 92). 3. Restart the print job

Problem list index

1. Forms problems index

“Forms buckle, twist, jam, or tractor holes tear”

“Forms do not feed past printhead”

“Forms do not stack correctly”

“Characters are off registration” on page 157

2. Print quality and ribbon problems index

“Unreadable characters” on page 157

“Missing dots or irregular characters” on page 157

“Ribbon smudging forms” on page 157

“Printing is too light or partial characters print” on page 157

“Ribbon snagging, tearing, or not moving” on page 157

“Line-to-line horizontal misregistration” on page 158

3. Configuration problems index

“Printer doesn't print or prints wrong characters” on page 158

4. Miscellaneous problems index

“Printer has no power” on page 158

“Throughput of printer at half speed” on page 158

1. Forms problems index

Table 17. Forms buckle, twist, jam, or tractor holes tear

Problem	Page
Right tractor adjusted incorrectly	159
Printer is not at edge of the table	159
Forms supply too high	159
Forms supply not aligned with printer	159
Forms catching on carton edge.	159
Ribbon twisted or folded	159
Form contains excessive moisture	159
Forms seem defective	159

Table 18. Forms do not feed past printhead

Problem	Page
Change AFTA setting	159
Ribbon twisted or folded	159
Using thick, multi-part forms	159

Table 19. Forms do not stack correctly

Problem	Page
Forms do not stack correctly (table)	160
Forms do not stack correctly (rack)	160
The forms do not meet specifications.	160
Forms contain excessive moisture	160
Forms too dry	160

Table 20. Characters off registration

Problem	Page
First print position is adjusted incorrectly	160

2. Print quality and ribbon problems index

Table 21. Unreadable characters

Problem	Page
Ribbon dry or worn	160
AFTA setting needs decreasing	160
Poor quality multiple-part forms	160
Bidirectional adjustment needs to be made	160
Forms thickness exceeds forms specifications.	161

Table 22. Missing dots or irregular characters

Problem	Page
Ribbon worn	161
Ribbon twisted or folded	161
AFTA setting needs to be changed	161

Table 23. Ribbon smudging forms

Problem	Page
Ribbon twisted or folded	161
AFTA setting needs to be increased	161
Ribbon cartridge defective	161
Ribbon over inked	161

Table 24. Printing is too light or partial characters print

Problem	Page
AFTA setting needs to be changed	161
Ribbon guide not correct	161

Table 25. Ribbon snagging, tearing, or not moving

Problem	Page
Ribbon worn	162
Ribbon cartridge not properly installed	162

Table 26. Line-to-line horizontal misregistration

Problem	Page
Dot registration not aligned	162

3. Configuration problems index

Table 27. Printer doesn't print or prints wrong characters

Problem	Page
Printer doesn't print or prints wrong characters	162

4. Miscellaneous problems index

Table 28. Printer has no power

Problem	Page
Power cord not connected	162

Table 29. Throughput of printer at half speed

Problem	Page
Quiet Print function is set on	162

Forms problems

Causes are listed for each problem in order of priority.

Problem: Forms buckle, twist, jam, or tractor holes tear

- 1: The right tractor is adjusted incorrectly.
Solution: Move the right tractor to obtain proper forms tension. The tractor pins should be in the center of the tractor holes.
- 2: The printer is not at the edge of the table.
Solution: Move the printer to the front edge of the table if having problems with front forms path or move the printer to the rear edge of the table if having problems with the rear forms path.
- 3: The forms supply is not below the level of the printer.
Solution: Move the forms supply to the floor or on a shelf below the level of the printer.
- 4: The forms supply is not aligned with the printer.
Solution: Reposition the forms supply so that the forms feed evenly.
- 5: The forms are catching on the carton edge.
Solution: Remove the uneven carton edges, or remove the forms from the carton.

Note: As the forms reach the bottom of the box, this problem can occur more often.
- 6: The ribbon is twisted or folded.
Solution: Check the ribbon for folds or twists.
- 7: The forms contain excessive moisture.
Solution: Store the forms in a cool, dry place before using them, or store the forms in the printer area for 24 hours.
- 8: The forms are defective or do not meet specifications.
Solution: Try unloading the forms and then reloading forms. Forms should meet the requirements specified under Chapter 18, "Supplies, optional features, and maintenance," on page 145.

Problem: Forms do not feed past printhead

- 1: The Automatic Forms Thickness Adjustment (AFTA) setting for the paper source you are using needs to be changed.
Solution: See the procedure for adjusting the forms thickness setting through the operator panel under Chapter 9, "Printer adjustments," on page 115.
- 2: The ribbon is twisting or folding.
Solution: Replace the ribbon.
- 3: You are using thick multiple-part forms.
Solution: See the procedure for setting perforation safety to *Enabled* through the operator panel (see Chapter 8, "Printer setup," on page 101).

Problem: Forms do not stack correctly

- 1: The forms do not stack correctly on the table behind the printer.
Solution: Use the recommended table size (see Appendix A, "Printer specifications," on page 165).

Note: Up to 101.6 mm (4 in.) of forms may stack on the table behind the printer without decreasing the ability of the forms to stack correctly.
- 2: The forms do not stack correctly in the output rack on the table.
Solution: Check for obstructions to the forms path (cables, cords, or other items). If you find an obstruction, remove or relocate it.
- 3: The forms do not meet specifications.
Solution: The forms may be outside nominal specifications (see Chapter 18, "Supplies, optional features, and maintenance," on page 145).
- 4: The forms contain excessive moisture.
Solution: Store the forms in a cool, dry place before using them or leave in the printer for 24 hours.

Note: Forms stack best when the forms are 203.2 to 304.8 mm (8 to 12 in.) long. If the forms length is outside this range, operator assistance may be needed.
- 5: Forms are too dry.
Solution: Condition the forms for 24 hours or more at the manufacturer recommended temperature and humidity settings.

Problem: Characters are off registration

- 1: The first print position is adjusted incorrectly.
Solution: Check your settings for the left margin, tear position, and the paper load position (see Appendix A, "Printer specifications," on page 165).

Print quality and ribbon problems

Problem: Unreadable characters

- 1: The ribbon is dry or worn.
Solution: Check the ribbon and replace it if it is dry or worn.
- 2: The Automatic Forms Thickness Adjustment (AFTA) setting for the paper source you are using needs to be decreased. Paper must be loaded for this adjustment to be effective.
Solution: See the procedure for adjusting the forms thickness setting through the operator panel (see Chapter 9, "Printer adjustments," on page 115).
- 3: Poor quality multiple-part forms.
Solution: Try new forms (Fast Draft)
- 4: Bidirectional adjustment needs to be made.
Solution: See the procedure for setting the bidirectional adjustment (see "Bidirectional Adjustment" on page 120).

- 5: Forms thickness exceeds forms specifications.
Solution: Use forms that meet specifications (see “Continuous forms specifications” on page 145).

Problem: Missing dots or irregular characters

- 1: The ribbon is worn.
Solution: Check the ribbon for wear; replace it if necessary.
- 2: The ribbon is twisted or folded.
Solution: Straighten the ribbon.
- 3: The Automatic Forms Thickness Adjustment (AFTA) setting for the paper source you are using needs to be changed. Paper must be loaded for this adjustment to be effective.
Solution: See the procedure for adjusting the forms thickness setting through the operator panel (see Chapter 9, “Printer adjustments,” on page 115).

Problem: Ribbon smudging forms



CAUTION:

<2-25> High temperature; switch off the printer and allow at least 20 minutes for parts in this area to cool before handling.

- 1: The ribbon is twisted or folded.
Solution: Try moving the printhead back and forth while turning the ribbon advance knob. If the ribbon advance knob does not turn, replace the ribbon.
- 2: The Automatic Forms Thickness Adjustment (AFTA) setting for the paper source you are using needs to be increased. Paper must be loaded for this adjustment to be effective.
Solution: See the procedure for adjusting the forms thickness setting through the operator panel (see Chapter 9, “Printer adjustments,” on page 115).
- 3: The ribbon cartridge is defective.
Solution: Replace the ribbon cartridge.
- 4: A new ribbon is over-inked.
Solution: Replace the ribbon.

Problem: Printing is too light or partial characters print

- 1: The Automatic Forms Thickness Adjustment (AFTA) setting for the paper source you are using needs to be changed. Do not attempt to manually move the AFTA wheel. Paper must be loaded for this adjustment to be effective.
Solution: See the procedure for adjusting the forms thickness setting through the operator panel (see Chapter 9, “Printer adjustments,” on page 115).
- 2: The ribbon guide is seated incorrectly or the white snap arm is not snapped into place.
Solution: Remove the ribbon and reinstall it.

Problem: Ribbon snagging, tearing, or not moving

1: The ribbon is worn.

Solution: Replace the ribbon cartridge.

2: The ribbon cartridge is not properly installed.

Solution: Remove and then reinstall the same ribbon.

Problem: Line-to-line horizontal misregistration

1: The dot registration of the characters printed is not aligned.

Solution: See Chapter 9, "Printer adjustments," on page 115.

Configuration problems

Problem: Printer doesn't print or prints wrong characters

1: Nothing is printed or the wrong characters print.

Solution:

- Ensure the printer cable is attached to the host.
- Check the configuration menu parameter values for your printer attachment (see Chapter 7, "ASCII Configuration," on page 67).

Miscellaneous problems

Problem: Printer has no power

1: The power cord is not connected.

Solution: Ensure the power cord is plug into the back of the printer and also into the wall outlet.

Problem: Throughput of printer at half speed

2: The Quiet Print function is set on.

Solution: Ensure the "Quiet Print" function in the Printer Configuration menu is disabled.

Clearing forms jams

Use the following procedure to clear forms jams from the printer.

1. Open the top cover.
2. Tear off the forms at perforations before it enters the printer and after it exits the printer.
3. Open the tractor doors and remove forms from the tractors.
4. Try to move the printhead off of the form and to the far right. **Do not force it.**
5. Remove jammed forms by pulling in the direction of printing.
6. If the jam cannot be removed, lightly pull the form in the opposite direction.
7. If the jam still cannot be removed, remove the bail assembly (if it is present):
 - a. Open the forms guide.
 - b. Remove the ribbon cartridge. (See “Removing the ribbon cartridge” on page 149.)
 - c. Grip the bail assembly as shown in the following illustration. Rotate it toward the front of the printer until the pivot posts on the sides disengage from the printer frame.

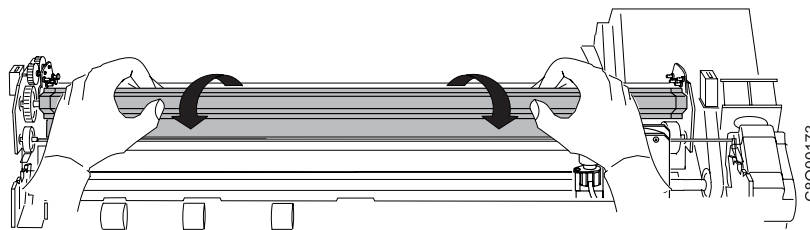

Figure 40. Rotating the bail assembly

- d. Lift the bail assembly out of the printer and set it aside.
 - e. Remove jammed forms by pulling in the direction of printing.
8. If you removed the paper bail assembly in the previous step, reinstall it, as follows:
 - a. Grip the bail assembly as shown in the following illustration.

Important!

To avoid damaging the plastic, ensure the plastic points down.

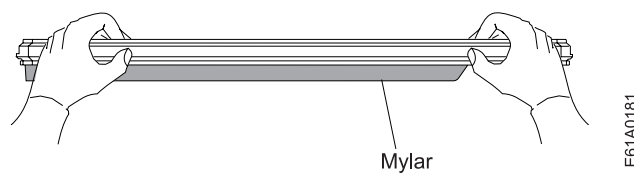

Figure 41. Gripping the bail assembly

- b. Insert the left and right paper bail end cap pivots into the side frames.

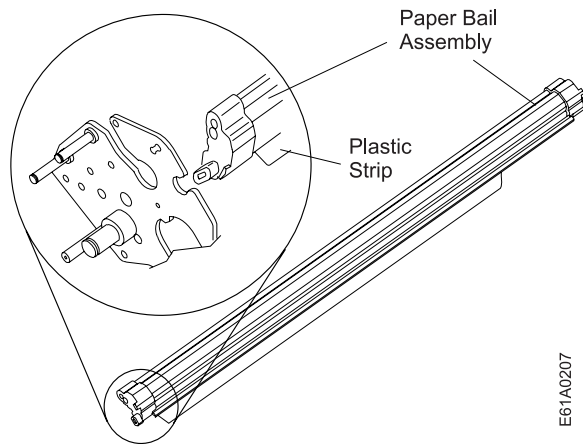

Figure 42. Inserting the left and right paper bail end cap pivots into the side frames

- c. Rotate the paper bail assembly toward the back of the printer, closing it as far as it will go.
 - d. Reinstall the ribbon cartridge.
 - e. Close the forms guide.
9. Reload the forms.

Appendix A. Printer specifications

General information	165	The LAN Interface	169
Operating and service clearance	166	LED indicators	169
Weight	166	Environmental requirements	169
Power consumption	166	Operating environment	169
Heat output	166	Shipping environment	169
Airflow	167	Storage environment	170
Declaration of product noise emission values	167	Electrical requirements	170
The Parallel Interface	167	Power cord	170
Parallel connector pin assignments	167	Safety	171
The Serial Interface	168	Branch circuits and grounding.	171
RS-232C connector pin assignments	168		

General information

The site that you select for your new printer must meet the specifications and conditions shown on the following pages.

As you consider the location and surrounding environment for your printer, avoid factors that can create a buildup of an electrostatic charge on the printer. While not harmful, an electrostatic discharge can cause discomfort to persons. Such discharges also can cause problems with printer operation or to the machines to which the printer connects. Some factors to avoid that can cause an electrostatic charge to build are:

- Floor surfaces with low resistance to electrical charges
- Carpeting without antistatic properties
- Plastic seat coverings
- Metal-frame furniture
- Low-humidity environment

If the printer is set up on a raised floor, you may need to provide an access area for the cord and cables that exit at the rear of the printer.

For reliable form feeding and forms handling, We recommend a printer stand or table. We offer an optional printer stand for the 4247 Printer. For more information on this printer stand, contact your marketing representative. For additional information on stacking, see “Proper forms loading” on page 146.

Operating and service clearance

You should provide adequate space for cooling air, and for operating or maintaining the printer. This is also helpful if you will occasionally change the Controller Board. Often, as little as 450 mm (18 in.) of extra table space (or floor space, for a printer on the optional printer stand) is adequate to service a printer.

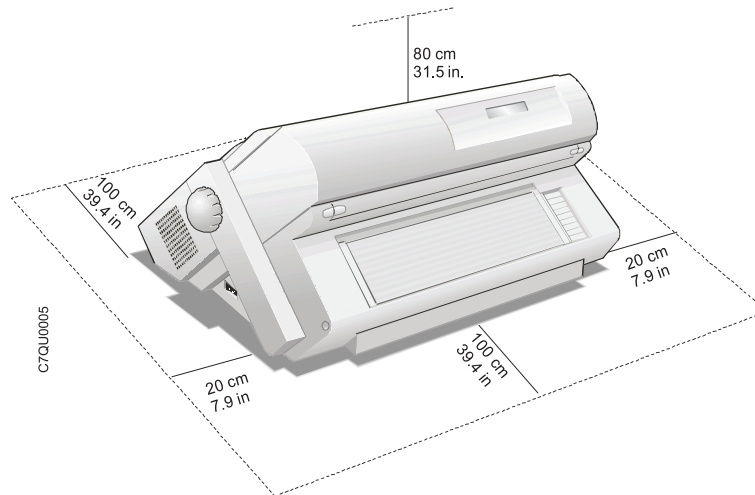

Figure 43. Printer clearances.

Weight



CAUTION:
The 4247 printer weighs 21 kg (46 lbs). Two persons are required to lift it.

Power consumption

Category	115 Vac 60 Hz	230 Vac 50 Hz
Maximum (Peak)	220 Watts	210 Watts
Operating (Maximum Typical)	155 Watts	145 Watts
Power Saver Mode*	19.2 Watts	20.2 Watts
Idle (Off Mode)	0.1 Watts	0.1 Watts
*Power Saver timeout is 23 seconds.		

Heat output

Category	115 Vac 60 Hz	230 Vac 50 Hz
Operating (Maximum Typical)	147 Watts (500 BTU/hr)	138 Watts (470 BTU/hr)
Idle	23 Watts (75 BTU/hr)	23 Watts (75 BTU/hr)

Airflow

The printer uses two fans to cool its internal parts. Be sure that you do not block the air vents. Lack of correct cooling and ventilation can cause printer failures and improper operation.

Declaration of product noise emission values

The following tables show the noise emission values for the 4247 Printer.

Table 30. Sound Emission Levels - with Standard Covers

Sound Emission Category	Operating	Idling
LWAd (1 bel = 10 decibels)	6.8 bels	3.7 bels
<LpA>m (bystander positions)	57.9 decibels	26.7 decibels

Notes:

1. LWAd is the declared sound power emission level for a production series of machines.
2. <LpA>m is the mean value of the space-averaged sound pressure emission levels at the one-meter position.
3. The principle printer configuration used to measure the noise emission levels with standard covers was:
 - Standard covers
 - Front Push forms path
 - DP print quality
 - Without Quiet Mode

All measurements are made in accordance with International Organization for Standardization (ISO) 7779 and reported in conformance with the International Organization for Standardization (ISO) 9296.

The Parallel Interface

The 4247 Printer supports the Parallel Printer Interface. A single, 36-pin connector is mounted on the adapter card.

Attach the PC-parallel interface to the host by using one of the following cables:

- Standard PC parallel printer cable, up to 1.8 m (6 ft) in length
- 1284 Bidirectional parallel printer cable, up to 4.57 m (15 ft) in length

Parallel connector pin assignments

Pin Number	Signal Name	Description
1	-STROBE	Strobe
2 - 9	DATA	Eight Data Lines
10	-ACKNLG	Acknowledge
11	BUSY	Busy
12	PE	Out of Paper
13	SLCT	Printer Selected
14	-AUTO FEED XT	Automatic Line Feed on EOL
15	Unused	

Pin Number	Signal Name	Description
16	LOGIC GND	Logic Ground
17	CHASSIS GROUND	Chassis Ground
18	+5 VDC	External Power
19 - 30	GROUND	Ground
31	-INIT	Initialize Printer
32	-ERROR	Printer Error
33	GROUND	Ground
34, 35	Unused	
36	-SLCT IN	Make printer selected

The Serial Interface

The 4247 Printer attaches to a host or controller with the RS-232C Serial Interface. A single 9-pin D-connector mounted directly on the adapter card allows attachment to the interface.

The RS-232C interface uses a standard serial cable up to 15.2 m (50 ft) in length, with transmission rates up to 19.2 Kbps.

RS-232C connector pin assignments

Table 31 lists the RS232/C serial interface signals:

Table 31. RS232/C serial interface signals

Signal Name	Pin Number	Local Connect. Source	Remote Connect. Source	Description
SIGNAL GROUND	5	–	–	Always connected to the 0 Volts of the Power Supply
TXD	3	Printer	Printer	Transmitted Data Signal (an output from printer). A MARK condition is held during IDLE communication state. An indeterminate state is present when printer is powered off.
RXD	2	Host	Data Set	Received data signal (an input to printer).
RTS	7	Printer	Printer	Request to Send Signal (an output from printer). Active HIGH level signal. It is HIGH until the printer is powered off, then an indeterminate state is present .
CTS	8		Data Set	Active HIGH level signal indicates that the host or data set is ready to receive data from the printer.
DSR	6		Data Set	Active HIGH level signal. Indicates that the host or data set is ready to be connected to the printer and is ready for data transfer.
DCD	1		Data Set	Active HIGH level signal. Indicates that the host is transmitting or the data set is receiving the Data Carrier signal.
2nd RTS	9	Printer		Functionally equivalent to the DTR signal.

Table 31. RS232/C serial interface signals (continued)

Signal Name	Pin Number	Local Connect. Source	Remote Connect. Source	Description
DTR	4	Printer	Printer	Data Terminal Ready. Normally HIGH (ON). Indicates that the printer is ready to initiate a connection.

The LAN Interface

LAN Interface Port

1. Ethernet 10/100BaseT Connector
2. Green 10/100Mbit/sec. Transmission Speed LED
3. Yellow Traffic LED

LED indicators

The LED indicator modes are described in the following table:

LED	Status	Description
Yellow LED	Unlit	Transmission speed at 10Mbit/sec.
	Lit	Transmission speed at 100Mbit/sec.
Green LED	Blinks	Transmitting or receiving packets from the network.

Environmental requirements

The printer operates correctly in environments that are typical of most business offices.

Attention: Damage to the printer can occur if you power on (I) the printer immediately after the printer has been moved from an environment that does not meet the following operating requirements. If the printer has been in such a location, be sure that you move the printer to the correct operating environment at least 24 hours before you power on (I) the printer.

Operating environment

The following table shows the operating environment requirements for the printer.

Environment	Requirement
Temperature range	10° to 40° C (50° to 104°F)
Relative humidity range	10% to 90% RH (non-condensing)

Note: The best conditions for feeding and stacking are within a temperature range of 15.6 to 32.2°C (60 to 90°F) and a relative humidity range of 26 to 62%.

Shipping environment

The following table shows the shipping environment requirements for the printer.

Note: You must cover the printer with a plastic cover for shipping.

Environment	Requirement
Temperature range	-35° to 65°C (-31° to 149°F)
Relative humidity range	5% to 95% RH (non-condensing)

Storage environment

The following table shows the storage environment requirements for the printer.

Environment	Requirement
Temperature range	-35° to 65°C (-31° to 149°F)
Relative humidity range	5% to 95% RH (non-condensing)

Note: Ribbon performance and print quality may degrade when exposed to temperatures in excess of 41°C (105°F) for an extended period of time.

Electrical requirements

Use the following tables to plan your site power requirements. The tables list the voltage inputs, grounding, plugs, and receptacles necessary for your new printer. All voltages are single-phase.

Nominal Operation Voltages

Countries	100 V to 127 V 50 or 60 Hz	200 V to 240 V 50 or 60 Hz
United States, Canada	X	
Central and South American, and Far Eastern	X	X
European, Middle Eastern, and African	Saudi Arabia, only	X

Power cord



DANGER

<1-11> Your country may require an approved power cord and plug. Ensure that you have the correct power cord and plug. Use this cord and plug only with an approved, correctly-installed power receptacle.



DANGER

DANGER<1-1> Do not use an extension power-cord.

Place the printer so the power cord can plug into the power receptacle without putting stress on the power cord. The standard power cord length in the U.S. and in all other countries is 2.74 m (9 ft). A 1.83 m (6 ft) power cord is also available in the U.S.

Safety

Safety is a major consideration in the design and manufacture of our products. Proper electrical grounding is essential for safety and for reliable operation of the printer. If you have any questions about the grounding of your receptacle, ask your electrician.

Branch circuits and grounding

A machine must be properly grounded. It is recommended that an insulated green-wire ground, the same size as the phase wire, be installed between the branch circuit panel and the receptacle.

For personal safety, the ground should have sufficiently low impedance to limit the voltage to ground and to facilitate the operation of circuit protective devices in the circuit. For example, the ground path must not exceed 1 ohm for 120-volt, 20-ampere branch circuit devices.

DANGER



<1-30> The construction of this printer provides extra protection against the risk of electrical shock by grounding appropriate metal parts. The extra protection may not function unless the power cord is connected to a properly-grounded outlet. This printer has a grounding-type (3-wire) power cord because grounding is necessary. It is the responsibility of the customer to the person installing the printer to connect it to a properly-grounded outlet. Seek professional assistance before using an adapter or extension cord; such a device could interrupt the grounding circuit. If this printer is connected to an outlet that has been incorrectly connected to the building wiring, serious electric shock could result.

Appendix B. 4247 Model X03 - Configuration Menu

Parameter	Value	Default
Configuration Storage		
Save Current Values	Custom Set A to H	----
Recall Custom Set Values	Custom Set A to H	----
Power-On Custom Set	Last Used, Custom Set A to H	[Last Used]
Power-On Paper Source	Last Used, Front, Rear	[Front]
Recall Factory Defaults	Yes	----
Attachment	Hot Port Switch, Parallel, Serial (1), USB (2), LAN ASCII (3), LAN IPDS (4)	[Hot Port Switch]
IPDS Configuration (4)		
Characters Per Inch	10, 12, 15, 16.7	[10]
Lines Per Inch	6, 8	[6]
Maximum Print Position	001 to 227	[132]
Maximum Page Length	001 to 880	[066]
Print Quality	DP Quality, DP Text Quality, Near Letter Quality	[DP Quality]
Print Language	037 to 1149	[500 International 5]
Emulation Mode	4247, 4224, 4230	[4247]
Media Size Priority	Standard, Alternate	[Alternate]
Bar Code Mode	High, Low, Computer Selected	[High]
Graphics Mode	High, Low, Computer Selected	[High]
Alarm Control	Disabled, Enabled	[Enabled]
ASCII Configuration		
Characters Per Inch	10, 12, 15, 16.7, 17.1, 20	[10]
Lines Per Inch	6, 8	[6]
Maximum Print Position	001 to 272	[136]
Maximum Page Length	001 to 880	[066]
Perforation Skipping	000 to 879	[000]
Emulation Mode	4247, 2381 Personal Printer, 4202 ProPrinter III XL, Epson-FX	[4247]
Print Language	000 to 1251	[437 PC] ¹ [0 USA] ²
Print Quality	DP Quality, DP Text Quality, Near Letter Quality, Courier, Gothic, OCR-A, OCR-B	[DP Quality]
NLQ Typeface	Courier, Gothic	[Courier]
Character Set	PC1, PC2, Italics	[PC1]
Printer Compatibility		
3 (Auto LF on CR)	Disabled, Enabled	[Disabled]
4 (Auto CR on LF)	Disabled, Enabled	[Disabled]
5 (FF Suppression)	Disabled, Enabled	[Disabled]
6 (Init)	Disabled, Enabled	[Enabled]
7 (Condensed Print)	15 CPI, 16.7 CPI, 17.1 CPI	[17.1 CPI]
8 (Slashed Zero)	Disabled, Enabled	[Disabled]
9 (20 CPI)	Disabled, Enabled	[Enabled]
Alarm Control	Disabled, Enabled	[Enabled]
Override Host		
Paper Source	Disabled, Enabled	[Disabled]
Characters Per Inch	Disabled, Enabled	[Disabled]
Lines Per Inch	Disabled, Enabled	[Disabled]
Maximum Page Length	Disabled, Enabled	[Disabled]
Parallel Interface		
Interface Type	PC Parallel, 1284 Parallel	[PC Parallel]
Input Buffer Size	256, 2K, 12K, 32K, 64K, 128K	[32K]
Select-In	Disabled, Enabled	[Enabled]
AutoFeed-XT	Disabled, Enabled	[Disabled]
Serial Interface (1)		
Interface Type	RS-232C	[RS-232C]
Input Buffer Size	256, 2K, 12K, 32K, 64K, 128K	[32K]
Data Bits	7, 8	[8]

1. [437 PC] when the emulation is 4247, 2381 Personal Printer, 4240 ProPrinter III XL.

2. [0 USA] when the emulation is Epson-FX.

Parameter	Value	Default
Baud Rate	300, 600, 1200, 2400, 4800, 9600, 19200, 38400, 115200	[9600]
Parity	None, Odd, Even, Mark, Space	[None]
Pacing Control	DTR, XON/XOFF	[DTR]
Connection Type	Local, Remote	[Local]
LAN Interface (3)(4)		
IP Address Assignment	Fixed, DHCP	[Fixed]
IP Address	E.g. 127.000.000.000	[127.000.000.000]
Subnet Mask	E.g. 255.255.254.000	[255.255.254.000]
Default Gateway	E.g. 000.000.000.000	[000.000.000.000]
Host Name	A string of max. 14 characters	[4247_xxxxxx]
Workgroup Name	A string of max. 14 characters	[workgroup]
SMTp Service	Disabled, Enabled	[Disabled]
Mail Server Address	E.g. 000.000.000.000	[000.000.000.000]
E-mail Address (Receiver)	A string of max. 48 characters	[null string]
E-mail Address (Sender)	A string of max. 48 characters	[null string]

- (1) If serial attachment is installed.
(2) If USB attachment is installed.
(3) If LAN ASCII attachment is installed.
(4) If LAN ASCII/IPDS attachment is installed.

Parameter	Value	Default
Printer Setup		
Paper Source	Front, Rear	[Front]
Front Forms Backup	Disabled, Enabled	[Enabled]
Rear Forms Backup	Disabled, Enabled	[Enabled]
Continuous Forms Linking	Disabled, Enabled	[Disabled]
Form Feed Mode	Not Active in Ready State, Active in Ready State	[Not Active in Ready State]
Automatic Eject	Disabled, Enabled	[Disabled]
Automatic Restore	Disabled, Data, Timer nn Seconds (nn = 10, 20, 30, 40, 50)	[Disabled]
Continuous Forms Eject Mode	Immediate Eject, Delayed Eject	[Immediate Eject]
Bar Code Print Direction	Unidirectional, Bidirectional	[Bidirectional]
Graphics Print Direction	Unidirectional, Bidirectional	[Bidirectional]
Perforation Safety	Disabled, Enabled	[Disabled]
Jam Sensors	Disabled, Enabled	[Enabled]

Parameter	Value	Default
Printer Adjustments		
Front AFTA	-5, -4, -3, -2, -1, 0, +1, +2, +3, Fixed 1, Fixed 1.5, Fixed 2, Fixed 2.5, Fixed 3, Fixed 3.5, Fixed 4, Fixed 4.5, Fixed 5, Fixed 5.5, Fixed 6, Fixed 6.5, Fixed 7, Fixed 7.5, Fixed 8	[0]
Front Tear Position	-390 to +30	[0]
Front Left Margin Alignment	0 to 60	[0]
Front Paper Load Position	-30 to +360	[0]
Rear AFTA	-5, -4, -3, -2, -1, 0, +1, +2, +3, Fixed 1, Fixed 1.5, Fixed 2, Fixed 2.5, Fixed 3, Fixed 3.5, Fixed 4, Fixed 4.5, Fixed 5, Fixed 5.5, Fixed 6, Fixed 6.5, Fixed 7, Fixed 7.5, Fixed 8	[0]
Rear Tear Position	-390 to +30	[0]
Rear Left Margin Alignment	0 to 60	[0]
Rear Paper Load Position	-30 to +360	[0]

Parameter	Value	Default
Power On Reset	Yes	----
Display Language	000 English, 001 Deutsch, 002 Français, 003 Italiano, 004 Español, 005 Nederlands, 006 Dansk, 007 Português, 008 Norsk, 009 Svenska, 010 Suomi, 011 Polski	[000 English]

Parameter	Value	Default
Vital Product Data		
Serial Number	0000000	[0000000]
Device Specific Information	0000000000000000	[0000000000000000]
Quiet Print	No, Yes	NO
Hex Print	No, Yes	NO
Quit from Menu	Restore Previous Values	

Appendix C. Printer driver support

IBM pSeries AIX colon files

The 4247 printer is supported on AIX 4.1 and later using files that can be found and downloaded from our website. When installed, users can add a 4247 printer device with virtual printers under three emulation modes: IBM 2381, IBM Proprinter III XL, and Epson FX. The virtual printers provide automatic emulation mode switching to support multiple data streams on a single printer.

IBM System i workstation customization objects

To help you get started in attaching your printer to IBM System i systems. Printer Profile source files for creating Workstation Customization Objects (WSCST) for Host Print Transform can be downloaded from the IBM website. For additional information see the *IBM Workstation Customization Programming, SC42-3605* for details on Host Print Transform and the installation of these files on your system. For more information concerning Host Print Transform and the creation of additional workstation customization objects for this printer, refer to the *IBM AS/400 Printer Device Programming, SC42-3713* or *AS/400 Workstation Customization Function Programmer's Guide, SC41-0056*.

Index

Numerics

- 1284 Parallel interface type 86
- 20 CPI, parallel parameter 80
- 2381 Personal Printer emulation, parallel attachment 71
- 4202 Proprinter III XL emulation, parallel attachment 71
- 4214 emulation, IPDS Configuration 62
- 4224 emulation, IPDS Configuration 62
- 4230 emulation, IPDS Configuration 62

A

- activating Form Feed key 105
- adjusting
 - front automatic forms thickness adjustment 116
 - front left margin alignment 117
 - front paper load position 117
 - front tear position 116
 - rear automatic forms thickness adjustment 118
 - rear left margin alignment 119
 - rear paper load position 120
 - rear tear position 118
- adjusting forms 31
- adjustments, printer 115
- alarm
 - audible 29
 - beeper 29
 - enabling or disabling, IPDS Configuration 66
 - enabling or disabling, parallel 81
- Alarm Control, IPDS Configuration 66
- Alarm Control, parallel parameter 81
- ASCII attachment, configuring 67
- attachment selection, using 55
- attachment, selecting 55
- Attention, status indicator 28
- audible alarm 29
- audible alarm, description 29
- AutoFeed XT, parallel parameter 88
- Automatic Carriage Return on Line Feed, parallel parameter 76
- Automatic Eject, printer setup parameter 107
- automatic forms thickness (front), adjusting 116
- automatic forms thickness (rear), adjusting 118
- Automatic Line Feed on Carriage Return, parallel parameter 76
- Automatic Restore, printer setup parameter 108

B

- backing up front forms 102
- backing up rear forms 103
- Bar Code Mode, IPDS Configuration 64

- Bar Code Print Direction, printer setup parameter 110
- Baud Rate, serial parameter 90
- Bidirectional Adjustment, printer 120
- buffer size, parallel attachment 86
- buffer size, serial attachment 89

C

- cables
 - connecting 25
- CANCEL PRINT, function key 36
- canceling configuration changes 133
- canceling printer adjustments 121
- changing parameter values 38
- Character Set, parallel parameter 75
- Characters Per Inch (CPI), ASCII parameter 67
- Characters Per Inch (CPI), IPDS Configuration 57
- Characters Per Inch, parallel parameter 83
- checking and changing configuration parameters 37
 - configuration categories 40
 - exiting the configuration menu 39
- checking parameter values 38
- clearance, operating and service 166
- coax attachment, selecting 55
- Condensed Print, parallel parameter 79
- configuration categories
 - configuration storage 41
 - display language 47, 125
 - parallel configuration 42
 - power on reset 46, 123
 - printer adjustment 46, 115
 - printer setup 45
 - quit from menu 48
 - vital product data 47, 127
- Configuration Menu
 - ASCII Configuration category 67
 - Attachment Selection category 55
 - canceling changes 133
 - categories (summary) 40
 - changing 38, 39
 - Configuration Storage category 49
 - Display Language 125
 - IPDS Configuration 57
 - Power-On Reset 123
 - Printer Adjustments category 115
 - Printer Setup category 101
 - Vital Product Data 127
- configuration storage
 - custom sets 49
 - non-custom set 49
 - power-on custom set 51
 - power-on paper source 52
 - recall custom set values 51
 - recall factory defaults 53
 - save current values 50
- configuration values, changing 38

- Connection Type, serial parameter 92
- Continuous Forms Eject Mode, printer setup parameter 109
- Continuous Forms Linking, printer setup parameter 104
- controller board
 - handling 5
- Courier, parallel attachment 74
- Courier, parallel NLQ Typeface 75
- CPI, ASCII parameter 67
- CPI, IPDS Configuration 57
- Custom Set in Use Indicator 29
- custom sets, configuration storage value 49

D

- Data Bits, serial parameter 90
- deactivating Form Feed key 105
- Default Gateway, LAN Interface 95
- defaults (factory), restoring 53
- delayed ejection 109
- demo pages, print 139
- Device Specific Information,
 - changing 128
- display language 125
- DP (Data Processing) Quality, IPDS Configuration 60
- DP (Data Processing) Quality, parallel attachment 74
- DP Text Quality, IPDS Configuration 60
- DP Text Quality, parallel attachment 74
- dual push
 - forms specifications 145

E

- E-Mail Address (Receiver), LAN Interface 98
- E-Mail Address (Sender), LAN Interface 99
- ejection, automatic 107
- ejection, delayed 109
- ejection, immediate 109
- electrical requirements
 - branch circuits and grounding 171
 - power cord 170
 - safety 171
- Emulation Mode, IPDS Configuration 62
- Emulation Mode, parallel parameter 71
- ENTER function key 31
- environmental requirements
 - operating 169
 - shipping 169
 - storage 170
- Epson-FX emulation, parallel attachment 71
- exiting the Configuration Menu 39

F

- factory defaults, restoring 53
- Form Feed Mode, printer setup parameter 105
- Form Feed Suppression, parallel parameter 77
- FORM FEED, function key 34
- forms (continuous), linking 104
- forms (front), backing up 102
- forms (rear), backing up 103
- forms linking 138
- forms parking 138
- forms thickness (front), adjusting 116
- forms thickness (rear), adjusting 118
- forms, adjusting 31
- Front Automatic Forms Thickness, printer adjustment 116
- Front Forms Backup, printer setup parameter 102
- front forms, backing up 102
- Front Left Margin Alignment, printer adjustment 117
- Front Paper Load Position, printer adjustment 117
- front push
 - configuring printer for 15
 - forms specifications 145
 - Load/Eject key function 33
 - loading forms for 16
 - stack locations 147
 - stacking recommendations 147
- Front Tear Position, printer adjustment 116
- function keys 29

G

- getting started 1
 - configuring 15
 - installing ribbon 9
 - loading paper 16
 - locations 2
 - printing first document 19
 - unpacking 3
- Gothic, parallel attachment 74
- Gothic, parallel NLQ Typeface 75
- Graphics Mode, IPDS Configuration 65
- Graphics Print Direction, printer setup parameter 111

H

- heat output 166
- host form feed 77
- Host Name, LAN Interface 95

I

- immediate ejection 109
- indicator, Custom Set in Use 29
- indicators, status 27
- Init (signal), parallel parameter 78
- Input Buffer Size, parallel parameter 86
- Input Buffer Size, serial parameter 89
- input source, defining 101

- input source, power-on default 52
- installing
 - interface cables 25
 - template 8
- Interface Type, parallel parameter 86
- Interface Type, serial parameter 88
- IP Address Assignment, LAN Interface 93
- IP Address, LAN Interface 93
- IPDS Configuration 57
- Italic, parallel attachment 75

J

- Jam Sensors, printer setup parameter 113

K

- keys
 - cancel print 36
 - form feed 34
 - line feed 33
 - load/eject 33
 - menu 30
 - micro/scroll 30
 - PA1/enter (Coax) 31
 - PA2/return (Coax) 32
 - park/path 32
 - set top of form 35
 - start 35
 - stop 35
 - test 36

L

- language (print), IPDS Configuration 61
- language (print), parallel attachment 72
- LINE FEED, function key 33
- line feeds, parallel 76
- Lines Per Inch (LPI), IPDS Configuration 58
- Lines Per Inch (LPI), parallel parameter 68
- Lines Per Inch, parallel parameter 84
- linking continuous forms 104
- LOAD/EJECT, function key 33
- loading, automatic 108
- locations
 - components 2
- LPI, IPDS Configuration 58
- LPI, parallel parameter 68

M

- Mail Server Address, LAN Interface 97
- maintenance 149
 - cleaning the printer
 - covers 150
 - inside 150
 - removing the ribbon cartridge 149
- margin alignment (front left), adjusting 117
- margin alignment (front right), adjusting 119

- Maximum Page Length (MPL), IPDS Configuration 59
- Maximum Page Length (MPL), parallel parameter 70
- Maximum Page Length, parallel parameter 85
- Maximum Print Position (MPP), IPDS Configuration 58
- Maximum Print Position (MPP), parallel parameter 69
- Media Size Priority, IPDS Configuration 63
- Menu, function key 30
- MPL, IPDS Configuration 59
- MPL, parallel parameter 70
- MPP, IPDS Configuration 58
- MPP, parallel parameter 69

N

- Near Letter Quality, IPDS Configuration 60
- Near Letter Quality, parallel attachment 74
- NLQ Typeface, parallel parameter 75
- NLQ, IPDS Configuration 60
- non-custom set, configuration storage value 49

O

- OCR-A, parallel attachment 74
- OCR-B, parallel attachment 74
- operator and service clearance 166
- operator panel
 - audible alarm 29
 - display 28
 - function keys 29
 - status indicators 27
 - understanding 27
- operator panel keys 29
- operator panel language, changing 125
- ordering signal cables 148
- Override Host, parallel parameter 82

P

- Pacing Protocol, serial parameter 92
- page length (MPL), IPDS Configuration 59
- page length (MPL), parallel parameter 70
- paper bail 135
- paper load position (front), adjusting 117
- paper load position (rear), adjusting 120
- paper source 101
- paper source, power-on default 52
- Paper Source, printer setup parameter 101
- parallel configuration
 - alarm control 81
 - autofeed XT 88
 - character set 75
 - characters per inch 67
 - emulation mode 71

- parallel configuration (*continued*)
 - input buffer size 86
 - interface type 86
 - lines per inch 68
 - maximum page length (MPL) 70
 - maximum print position (MPP) 69
 - NLQ typeface 75
 - print language 72
 - print quality (Epson-FX) 74
 - print quality (PC parallel) 74
 - printer compatibility 76
 - select-in signal 87
- parallel, attach to 167
- parameter values, changing 38
- Parity, serial parameter 91
- PARK, function key 32
- PARK/PATH, function key 32
- parking continuous forms 138
- parking the printhead 112
- PATH, function key 32
- PC Parallel interface type 86
- PC1 (PC Character Set 1), parallel attachment 75
- PC2 (PC Character Set 2), parallel attachment 75
- Perforation Safety, printer setup parameter 112
- power consumption 166
- Power-On Custom Set, configuration storage value 51
- Power-On Paper Source, configuration storage value 52
- power-on reset (POR) 123
- Print Language, IPDS Configuration 61
- Print Language, parallel parameter 72
- print position (MPP), IPDS Configuration 58
- print position (MPP), parallel parameter 69
- Print Quality, IPDS Configuration 60
- Print Quality, parallel parameter 74
- printer
 - airflow 167
 - dimensions and clearances 166
 - sound levels 167
 - unpacking 3
 - weight 166
- printer adjustments
 - bidirectional adjustment 120
 - front forms load position 117
 - front forms thickness (AFTA) 116
 - front left margin alignment 117
 - front tear position 116
 - quit from menu 133
 - rear automatic forms thickness adjustment (AFTA) 118
 - rear forms load position 120
 - rear left margin 119
 - rear tear position 118
 - sensor tune 121
- printer attachment, selecting 55
- printer compatibility (parallel)
 - 20 CPI 80
 - automatic carriage return on line feed 76
 - automatic line feed on carriage return 76

- printer compatibility (parallel) (*continued*)
 - condensed print 79
 - form feed suppression 77
 - Init 78
 - slashed zero 79
- Printer Compatibility parameters, parallel attachment 76
- printer setup
 - automatic eject 107
 - automatic restore 108
 - bar code print direction 110
 - continuous forms eject mode 109
 - continuous forms linking 104
 - form feed mode 105
 - front forms backup 102
 - graphics print direction 111
 - jam sensors 113
 - paper source 101
 - perforation safety 112
 - rear forms backup 103
- printhead parking 112
- printing your first document 19
- Processing, status indicator 28
- push-pull
 - forms specifications 145

Q

- quality (print), IPDS Configuration 60
- Quick Reference, printing 140
- quit from menu 133

R

- Ready, status indicator 27
- Rear Automatic Forms Thickness, printer adjustment 118
- Rear Forms Backup, printer setup parameter 103
- rear forms, backing up 103
- Rear Left Margin Alignment, printer adjustment 119
- Rear Paper Load Position, printer adjustment 120
- rear pull
 - forms specifications 145
- rear push
 - forms specifications 145
 - Load/Eject key function 33
 - stacking recommendations 147
- Rear Tear Position, printer adjustment 118
- Recall Custom Set Values, configuration storage value 51
- Recall Factory Defaults, configuration storage value 53
- recalling factory defaults 53
- restoring factory defaults 53
- RETURN function key 32
- RS-232C serial interface type 88
- RS-422A serial interface type 88

S

- samples, print 139
- Save Current Values, configuration storage value 50
- saving current values in custom sets 50
- SCROLL/MICRO \uparrow , function key 30
- SCROLL/MICRO \downarrow , function key 30
- scrolling 31
- Select-In Signal, parallel parameter 87
- Sensor Tune, printer adjustment parameter 121
- sensors (jam), disabling 113
- Serial Number, changing 127
- SET TOP OF FORM, function key 35
- setup
 - configuring 15
 - installing the ribbon 9
 - loading paper 16
 - printing first document 19
 - unpacking 3
- Slashed Zero, parallel parameter 79
- SMS-XOH processing, IPDS Configuration 63
- SMTP Service, LAN Interface 97
- sound emission levels 167
- specifications
 - electrical requirements
 - branch circuits and grounding 171
 - power cord 170
 - safety 171
 - environmental requirements
 - operating 169
 - shipping 169
 - storage 170
 - physical requirements
 - airflow 167
 - heat output 166
 - noise emission values 167
 - power consumption 166
 - weight 166
- START, function key 35
- status indicators 27
- STOP, function key 35
- Subnet Mask, LAN Interface 94
- supplies
 - forms 145

T

- tear off information 106
- tear position (front), adjusting 116
- tear position (rear), adjusting 118
- template 8
- Test, function key 36
- tests, print 139
- Twinax configuration
 - alarm control 66
 - bar code mode 64
 - characters per inch 57
 - emulation mode 62
 - graphics mode 65
 - lines per inch 58
 - maximum page length (MPL) 59
 - maximum print position (MPP) 58
 - print language 61

Twinax configuration (*continued*)
print quality 60

U

unpacking the printer 3
using the operator print tests
firmware information 142
printer adjustments 142
printer configuration 141
printer demonstration 140
quick reference 140

V

very important (vital) data 127
vital product data
device specific information 128
serial number 127
Vital Product Data 127

W

Workgroup Name, LAN Interface 96

X

XOH-SMS processing, IPDS
Configuration 63

Z

zeroes (slashed), parallel parameter 79

Notices

Thanks for choosing the 4247 printer.

Your printer is a reliable working equipment that will be very useful in your daily job.

Our printers have been designed to be compact and respectful of the work environment. They offer a wide range of features and multiple functions that confirm the high technological level reached by the printers with Compuprint brand.

To maintain these printing performances unchanged in the long run, Compuprint has developed specific consumables for each printer type that assure an excellent operation with high printing quality level reliability.

Compuprint srl recommends to use only its original consumables with original packaging (identified by its holographic label).

In this way, a proper use of the printer at quality level stated in the product characteristics can be assured.

All typical usage problems related to not certified consumables may be avoided, such as an overall quality print level degradation and, often, the reduction of the product life due to the fact that the proper working conditions for the print heads and other printer parts are not assured.

Moreover, Compuprint does not only certify its consumables in terms of working conditions but also carefully controls their compliance with the international standard rules concerning:

- no cancerous materials;
- no flammability of the plastic materials;
- other standards

Compuprint advises the customers not to use products for which the compliance to this safety rules are not warranted. Finally seek your dealer or contact a Compuprint office and be sure that are provided you the original consumables.

FFC Notes

This equipment has been tested and found to comply with the limits for a Class A digital device, pursuant to Part 15 of the FCC Rules. These limits are designed to provide reasonable protection against harmful interference when the equipment is operated in a commercial environment.

This equipment generates, uses, and can radiate radio frequency energy and, if not installed and used in accordance with the instruction manual, may cause harmful interference to radio communications. Operation of this equipment in a residential area is likely to cause harmful interference in which case the user will be required to correct the interference at his own expense. Properly shielded and grounded cables and connectors must be used in order to meet FCC emission limits. Compuprint is not responsible for any radio or television interference caused by using other than recommended cables and connectors or by unauthorized changes or modifications to this equipment. Unauthorized changes or modifications could void the user's authority to operate the equipment. This device complies with Part 15 of the FCC Rules.

Operation is subject to the following two conditions: (1) this device may not cause harmful interference, and (2) this device must accept any interference received, including interference that may cause undesired operation.

European Union (EU) Conformity Statement

Compuprint srl declares that this product is in compliance with the essential requirements and other relevant provisions of Directive 2006/95/EC, 2004/108/EC.

Per the applicable requirements of EU directive 98/37/EC (“machines”) sound pressure of the above product (measured according to EN27779) does not exceed 70dBA.

This product has been tested and found to comply with the limits for Class A Information Technology Equipment according to European standard EN 55022. The limits for Class A equipment were derived for commercial and industrial environments to provide reasonable protection against interference with licensed communication devices. Important This is a Class A product. In a domestic environment this product may cause radio interference in which case the user may be required to take adequate measures.

Properly shielded and grounded cables and connectors must be used in order to reduce the potential for causing

interference to radio and TV communications and to other electrical or electronic equipment.

Compuprint srl cannot accept responsibility for any interference caused by using other than recommended cables and connectors.

Industry Canada Compliance Statement

This Class A digital apparatus complies with Canadian ICES-003.

Cet appareil numérique de la classe A est conforme à la norme NMB-003 du Canada.

Statement for CISPR 22 Edition 2 Compliance

Attention: This is a Class A product. In a domestic environment this product may cause radio interference in which case the user may be required to take adequate measures.

User Information according to European Directive 2002/95/EC and 2003/108/EC

This unit must be recycled or discarded according to applicable local and national regulations.



The symbol shown on the left, applied to the product or on its packing, indicates that, at end of life, the product is not to be thrown away, or disposed as unsorted municipal waste, but separately collected.

Compuprint srl encourages owners of information technology (IT) equipment to responsibly recycle their equipment when it is no longer needed.

Customer that needs to dispose this equipment must contact the produce and follow the collection framework available locally for the return, recycling and recovery of WEEE.

Customer participation to the separate collection is important to minimize any potential effects on the environment and human health, due to the potential presence of hazardous substances in the equipment, and aids the reuse and recycle of the materials by which the equipment is made.

Uncorrect disposal of the product by the customer will be punished according to the local regulations and Laws.



MAN10296.00.00

Printed in Italy

