

Compuprint 10300

User Manual



Compuprint Products Information

Thanks for choosing the 10300 printer.

Your printer is a reliable working equipment that will be very useful in your daily job.

Our printers have been designed to be compact and respectful of the work environment. They offer a wide range of features and multiple functions that confirm the high technological level reached by the Sferal printers with Compuprint brand.

To maintain these printing performances unchanged in the long run, Sferal wwt has developed specific Compuprint branded consumables for each printer type (for example: ribbon cartridges for dot matrix printers, toner and OPC cartridges for laser printers, bubble ink jet cartridges for inkjet printers) that assure an excellent operation with high printing quality level reliability.

Sferal wwt recommends to use only its original Compuprint branded consumables with original packaging (identified by its holographic label). In this way, a proper use of the printer at quality level stated in the product characteristics can be assured. All typical usage problems related to not certified consumables may be avoided, such as an overall quality print level degradation and, often, the reduction of the product life due to the fact that the proper working conditions for the print heads, OPC cartridge and other printer parts are not assured.

Moreover, Sferal does not only certify its consumables in terms of working conditions but also carefully controls their compliance with the international standard rules concerning:

- *no cancerous materials;*
- *no flammability of the plastic materials;*
- *other standards*

Sferal advises the customers not to use products for which the compliance to this safety rules are not warranted. Finally seek your dealer or contact a Sferal office and be sure that are provided you the original Compuprint branded consumables.

FFC Notes

This equipment has been tested and found to comply with the limits for a Class A digital device, pursuant to Part 15 of the FCC Rules. These limits are designed to provide reasonable protection against harmful interference when the equipment is operated in a commercial environment. This equipment generates, uses, and can radiate radio frequency energy and, if not installed and used in accordance with the instruction manual, may cause harmful interference to radio communications. Operation of this equipment in a residential area is likely to cause harmful interference in which case the user will be required to correct the interference at his own expense. Properly shielded and grounded cables and connectors must be used in order to meet FCC emission limits. SFERAL WWT is not responsible for any radio or television interference caused by using other than recommended cables and connectors or by unauthorized changes or modifications to this equipment. Unauthorized changes or modifications could void the user's authority to operate the equipment. This device complies with Part 15 of the FCC Rules. Operation is subject to the following two conditions: (1) this device may not cause harmful interference, and (2) this device must accept any interference received, including interference that may cause undesired operation.

European Union (EU) Conformity Statement

SFERAL WWT declares that this product is in compliance with the essential requirements and other relevant provisions of Directive 2006/95/EC, 2004/108/EC.

Per the applicable requirements of EU directive 98/37/EC ("machines") sound pressure of the above product (measured according to EN27779) does not exceed 70dBA.

This product has been tested and found to comply with the limits for Class A Information Technology Equipment according to European standard EN 55022. The limits for Class A equipment were derived for commercial and industrial environments to provide reasonable protection against interference with licensed communication devices.

Important This is a Class A product. In a domestic environment this product may cause radio interference in which case the user may be required to take adequate measures.

Properly shielded and grounded cables and connectors must be used in order to reduce the potential for causing interference to radio and TV communications and to other electrical or electronic equipment. SFERAL WWT cannot accept responsibility for any interference caused by using other than recommended cables and connectors.

Industry Canada Compliance Statement

This Class A digital apparatus complies with Canadian ICES-003.

Cet appareil numérique de la classe A est conforme à la norme NMB-003 du Canada.

Statement for CISPR 22 Edition 2 Compliance

Attention: This is a Class A product. In a domestic environment this product may cause radio interference in which case the user may be required to take adequate measures.

Table of Contents

Compuprint Products Information	ii
FFC Notes	iii
Canadian D.O.C. Radio Interference Regulation	iii
EEC Regulations	iii
Table of Contents	iv
Getting to Know Your Printer	1
Printer Features	1
Unpacking Your Printer	2
Removal of the Shipment Locks	6
Connecting the Ground Cable	8
Printer Parts	9
Front View	9
Rear View	10
Left Side View	11
Inside View	11
Setting Up Your Printer	12
Choosing a Suitable Location	12
Ribbon Cartridge Installation	13
Front2 Push Tractor Installation	18
Removing the Front2 Push Tractor	21
Host Computer Connection	22
Software Driver Selection	24
Power Connection	25
Selecting the Display Language	27
Configuring the Printer	28
Operator Panel Presentation	28
Display Messages	29
Indicators	34
Function Keys	35
Printer Setups	40
Entering the Printer Setups	40
Moving within the Printer Setups	40
Leaving the Printer Setups	41
Power-On Configuration	42
Entering the Power-On Configuration	42
Program Setup	80
Entering the Program Setup	80
ANSI Emulation	105
How to Select the Paper Path	116
How to Use the Tear-Off Function	117
Selection of the Paper Size	117
Adjusting the Tear-Off Position	118
Selection of the Tear-Off Mode	119
How to Lock/Unlock the Printer Setups	120
How to Handle the Paper Parking	121
Paper Handling	126
Paper Specifications	126
Fanfold Paper	126
Fanfold Paper Loading	127
Loading Paper Using the Front1 Push Tractor	127
Loading Paper Using the Front2 Tractor	137
Printer Maintenance and Troubleshooting	142
Cleaning the Printer	142
Replacing the Ribbon Cartridge	143
Printing the Self Test	145
Error Handling	146
Repacking the Printer for Shipment	149
Options	153
The Controller Board	153
Front2 Push Tractor	153
Printer Cabinet	153
Installing the Controller Board	154
Printer Specifications	158

Getting to Know Your Printer

Printer Features

- 24 Needle Print Head
- 136 columns @10 cpi
- High Speed Draft printing at 1300 cps, Draft printing at 950 cps and LQ printing at 133 cps
- IBM Proprinter XL24/XL24 AGM, Personal Printer 2391+, EPSON LQ Series and ANSI X3.64 emulations
- Multiple copies (1 original and 7 copies)
- Automatic paper path selection
- Easy operability via operator panel setup and S/W commands
- Use of all specific features by means of the Specific Software Driver which is applicable to the most popular S/W Packages
- Plug & Play capability for Windows 95/98/2000/XP/NT4.0/Millennium ®/Vista
- Bi-directional IEEE 1284 parallel interface, standard serial RS-232/C interface and USB interface
- Ethernet 10/100 Base-T interface option that coexists with the parallel interface
- Optional second Push Tractor and Printer Cabinet.

Unpacking Your Printer

The following items are included in the box:

Notify any damage to your supplier.



CD-Rom
(with User Manual included)

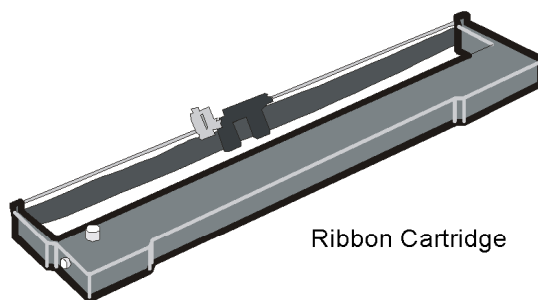

Ribbon Cartridge



Repacking Strips

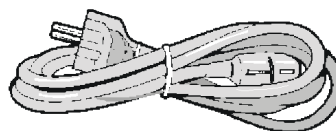

Power Cable

To unpack the printer proceed as follows:

Keep the packing material in a safe place. It must be used if you need to repack the printer for shipment.

1. Bring the printer box near the final printer location.
2. Cut the packing ribbons and remove the plastic angles.
3. Remove the polystyrene panel out of the packing box.

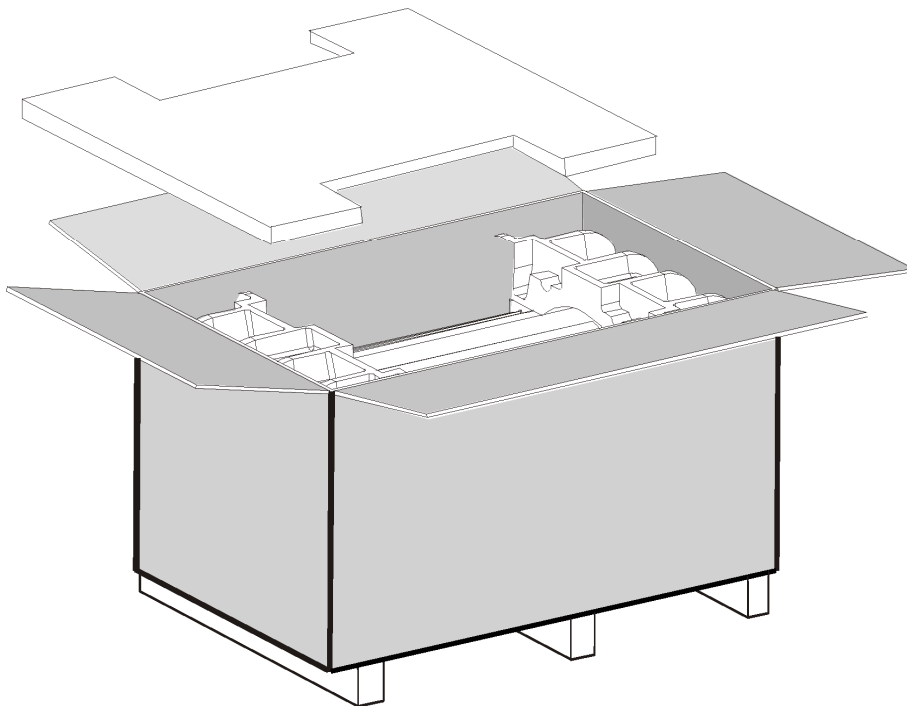

4. Remove the accessories out of the packing box and slide the packing box off the printer.

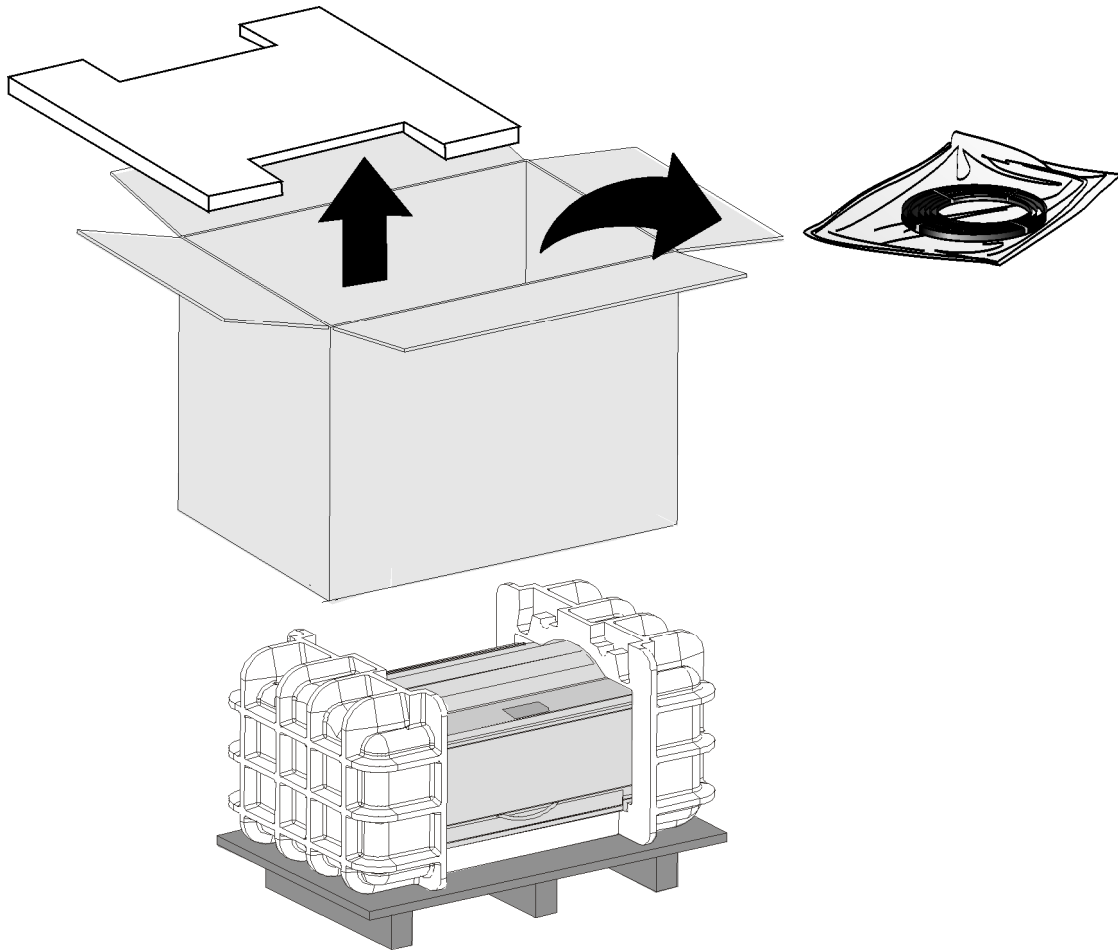

5. With the help of another person, remove the two foam shells on either side of the printer, the plastic bag covering the printer and the two carton strips.

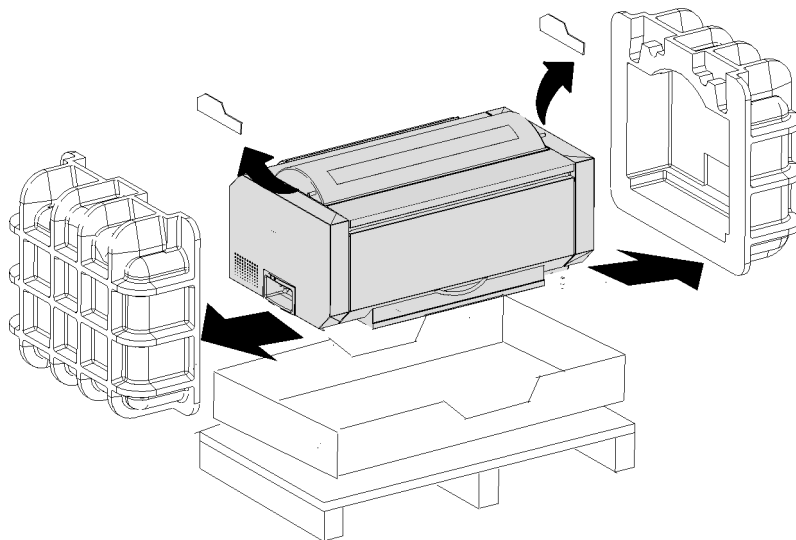

6. With the help of another person, move the printer to its final position:
- onto the printer cabinet (optional);
 - onto a stable surface, i.e. a table.



33 Kg / 73 Lbs

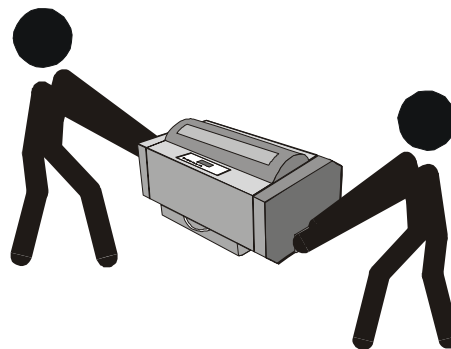

Removal of the Shipment Locks

1. Open the tractor area cover and make sure that you remove the shipment lock from the printer.

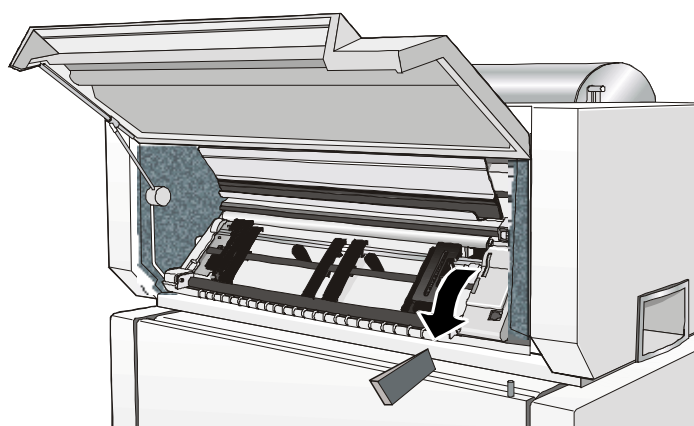

2. Unscrew the two fixing screws.

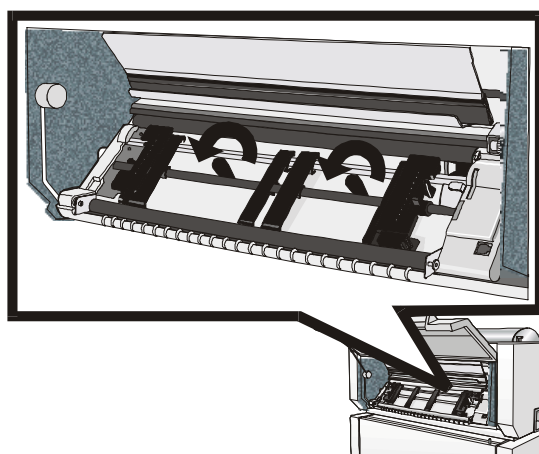

3. Open the upper printer cover and remove the fixing strip from the print head and from the bail (two strips).

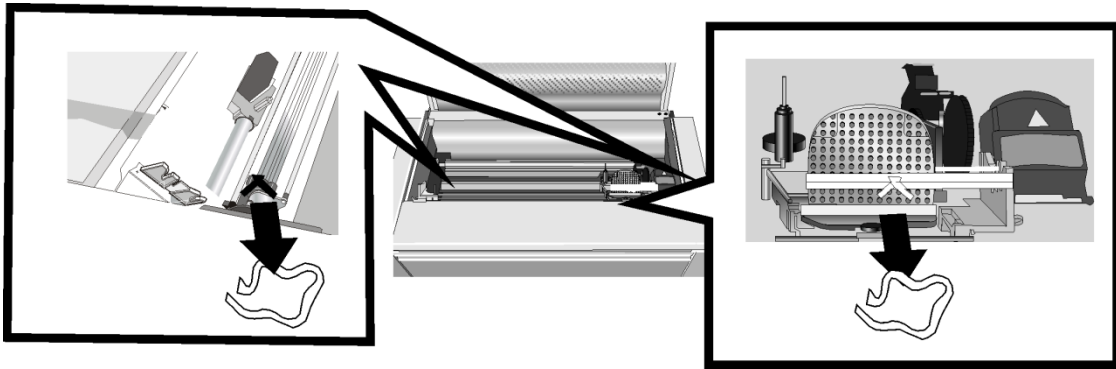

Keep all the packing material, together with the repacking kit, in a safe place. Repack the printer in its original packaging if you need to ship or transport it.

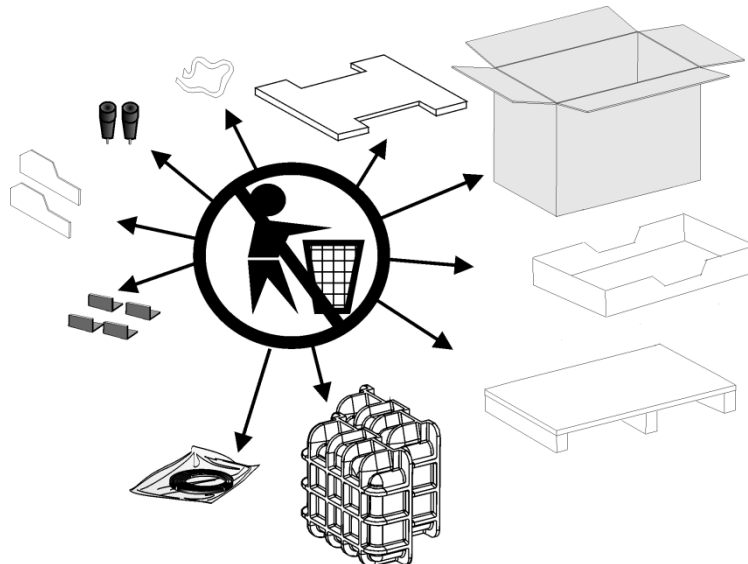

Connecting the Ground Cable

For the printer model with the cabinet option, connect the ground cable in the interface area on the rear side of the printer cabinet.

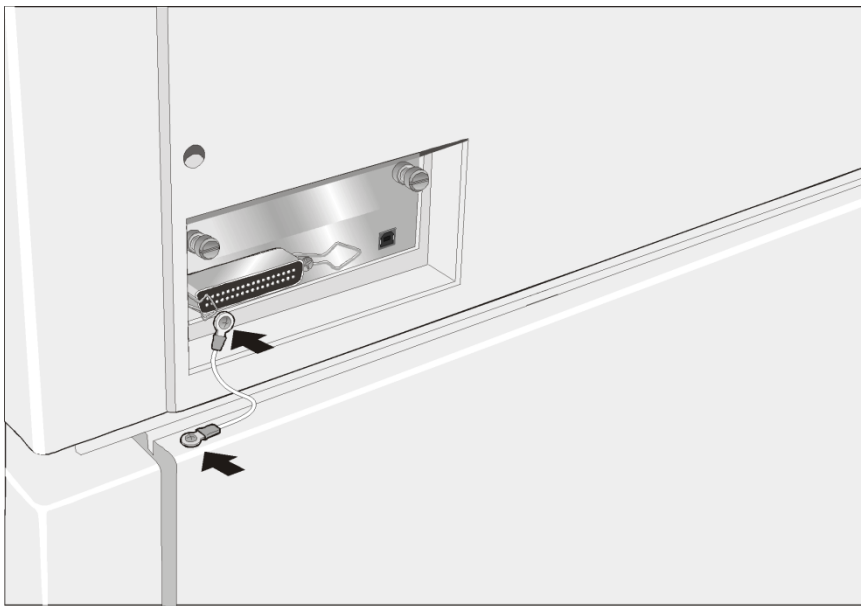

If the printer is installed on a table, it is not necessary to connect the ground cable.

Printer Parts Front View

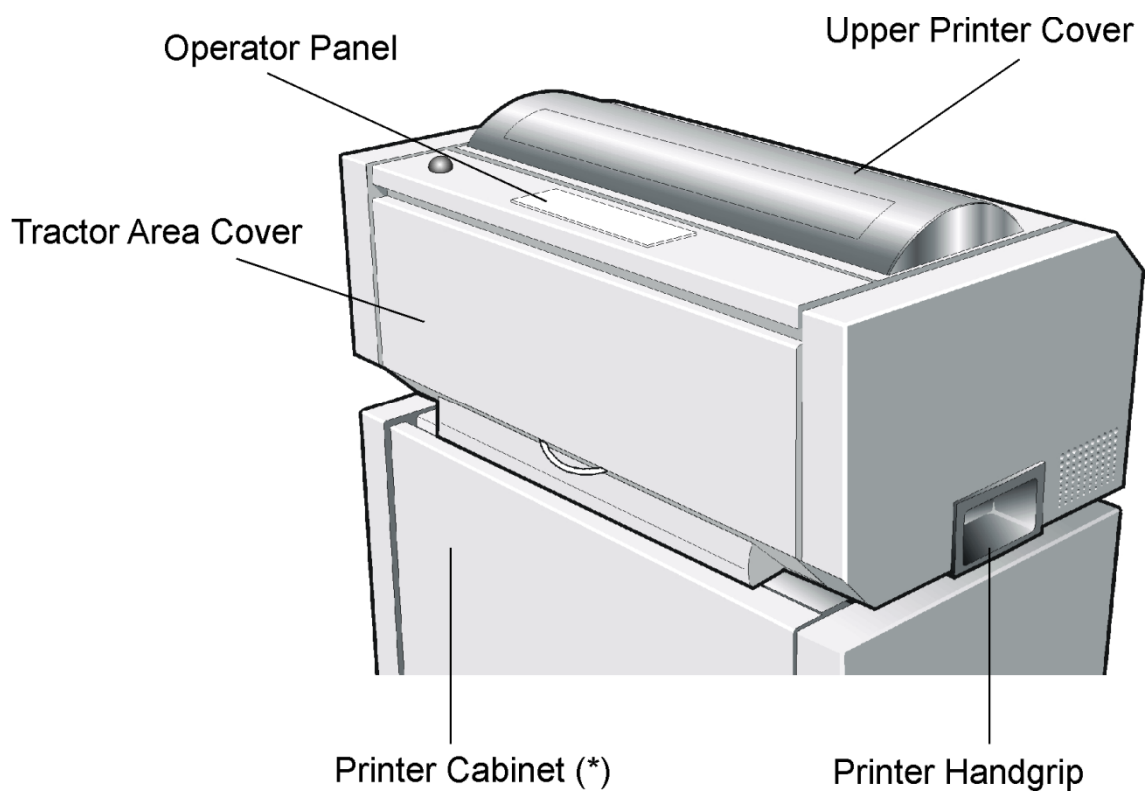

(*) The printer cabinet is available as an option.

Rear View

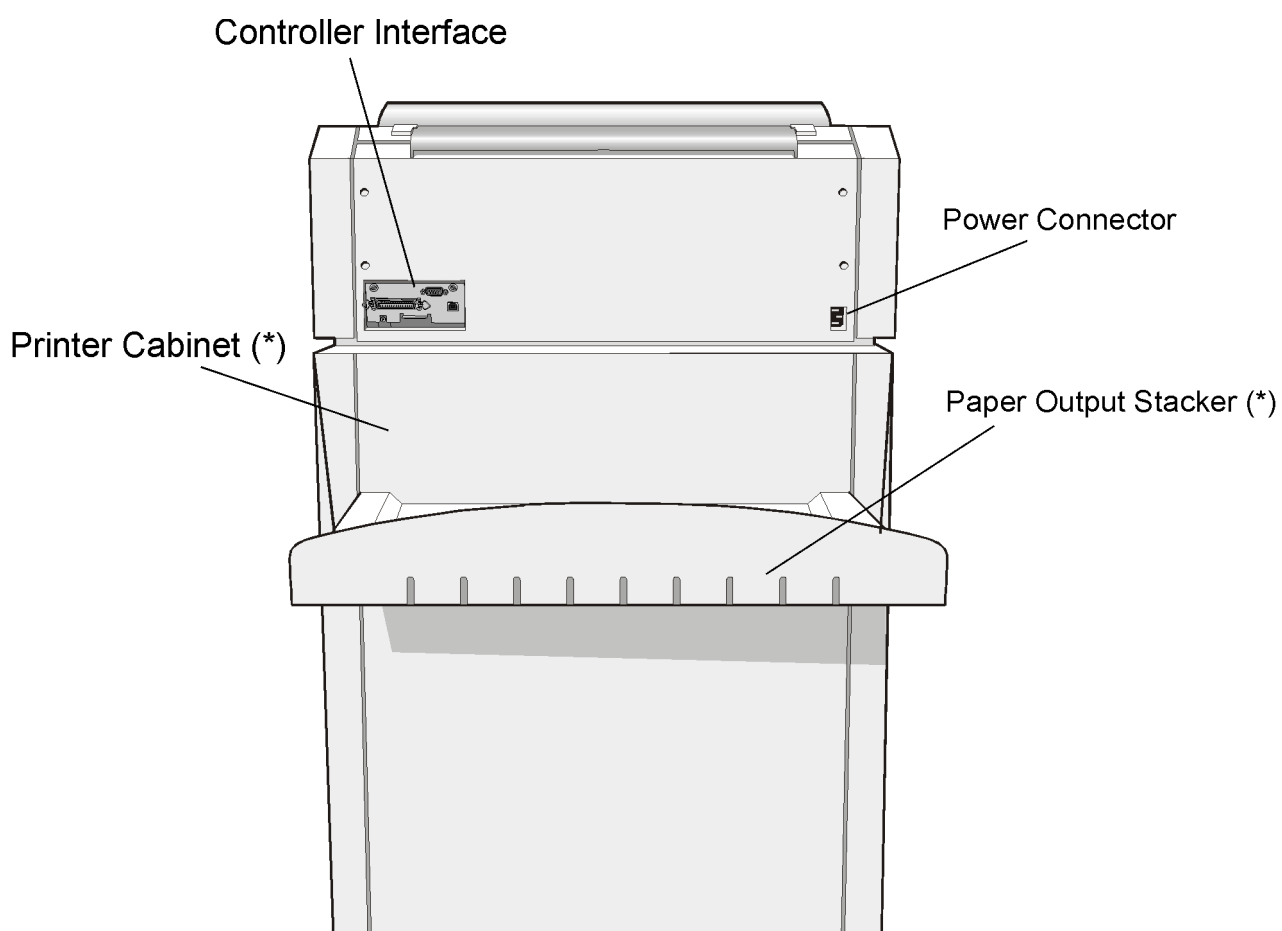

(*) The printer cabinet is available as an option.

Left Side View

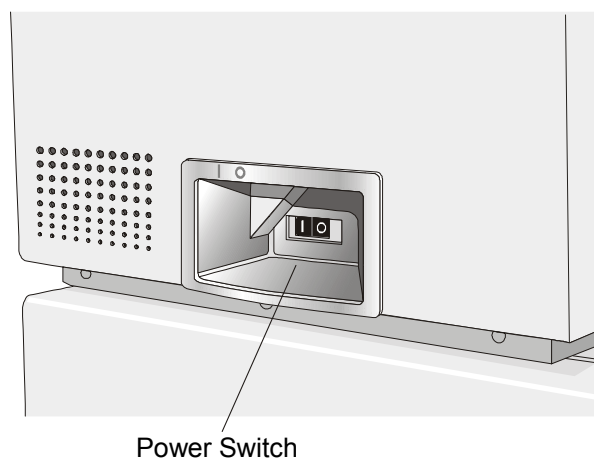

Inside View

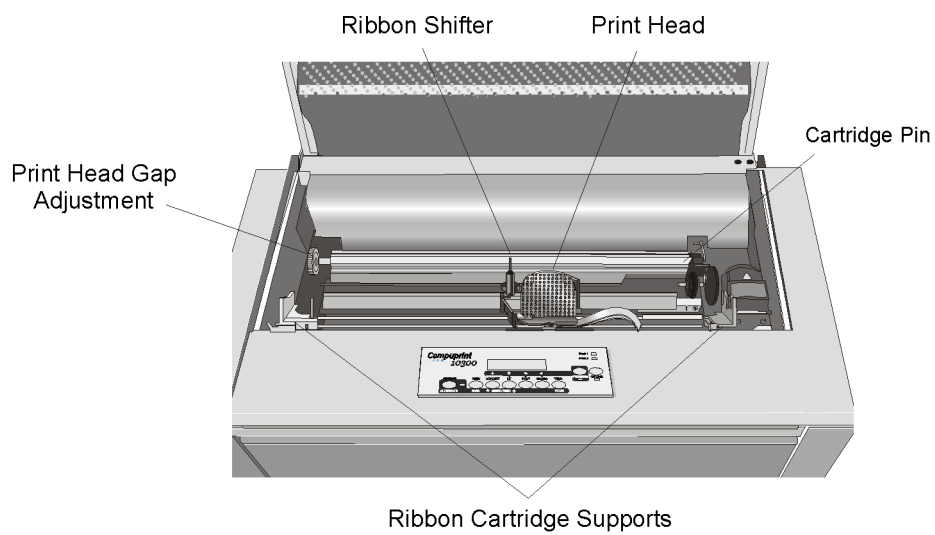

Setting Up Your Printer

Choosing a Suitable Location

Consider the following points when you choose the location for your printer:

- The distance between the printer and the host computer must not exceed the length of the interface cable;
- The location must be sturdy, horizontal and stable;
- Your printer must not be exposed to direct sunlight, extreme heat, cold, dust or humidity (see "[Printer Specifications](#)" later);
- You need a power outlet compatible with the plug of the printer's power cord;

Additionally, you must make sure that when you install the printer in the selected location, there are sufficient clearances on all sides for easy operation. The required space is shown in the figure:

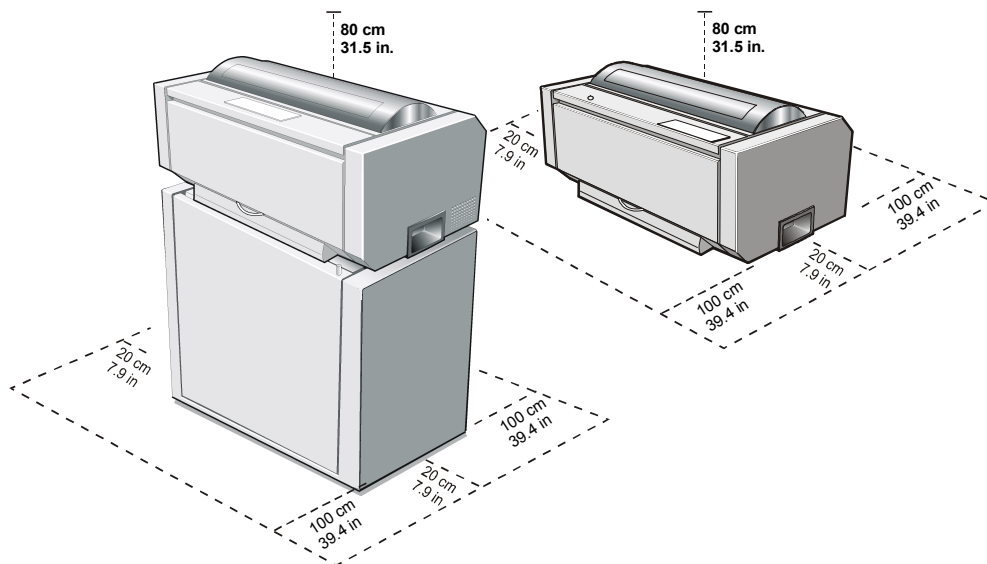

Ribbon Cartridge Installation

Make sure that you are using only **Compuprint** original consumables.

1. Make sure that the printer is turned off.
2. Find the ribbon cartridge among the accessories

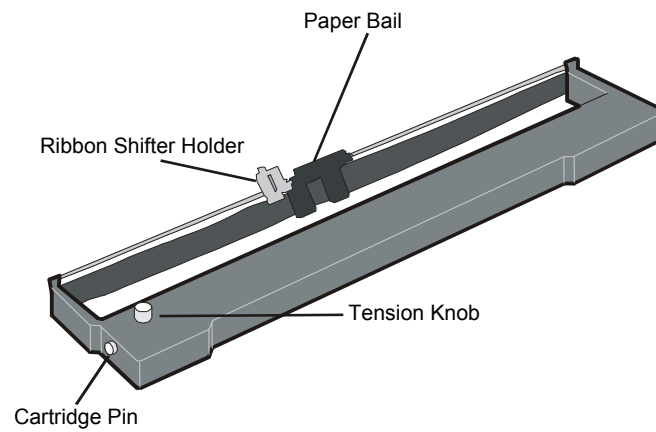

3. Turn the printer on and wait for printer initialization. Then press the ON LINE key to put the printer in OFF-LINE mode (check ON LINE indicator unlit).

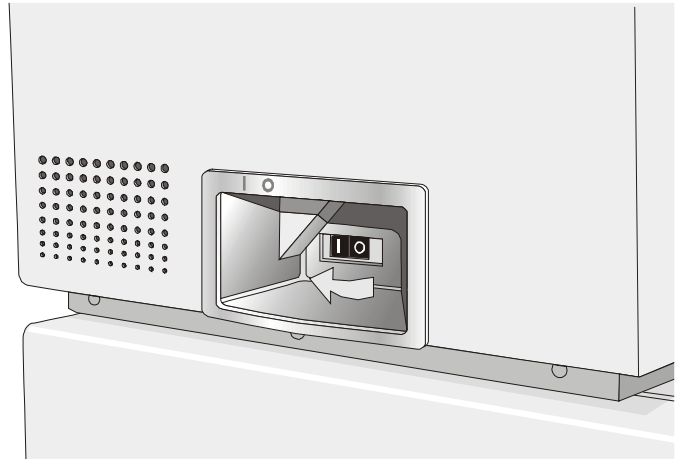

4. Open the top cover using the handles on the front side of the covers.

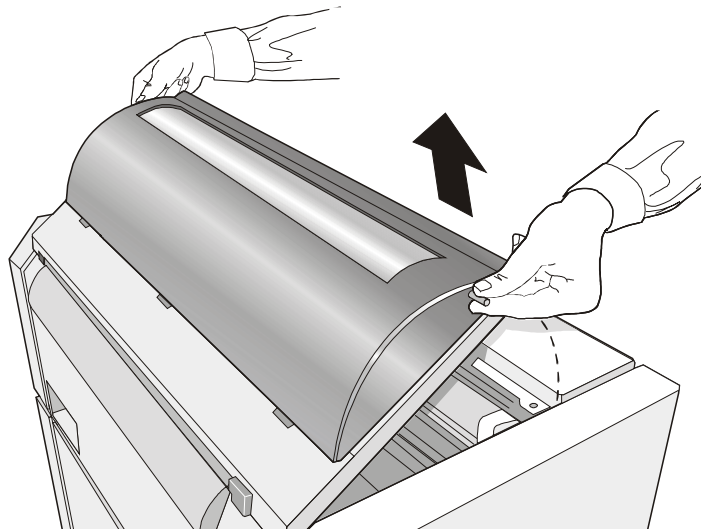

5. Before installing the ribbon cartridge turn the ribbon-winding knob in the arrow direction (located on the cartridge) to take up slack in the ribbon.

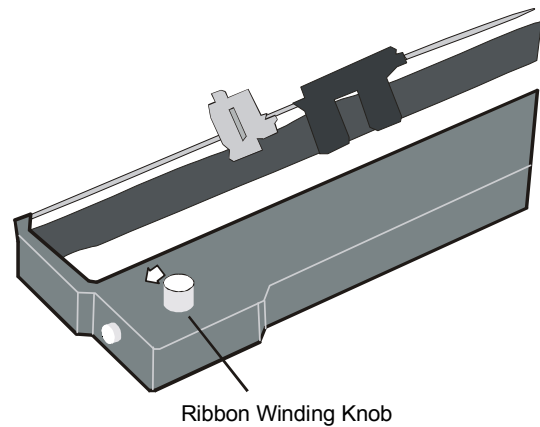

To avoid damage to the ribbon, do not turn the winding knob in the wrong direction.

6. Align the right and left cartridge pins with the printer locking points.

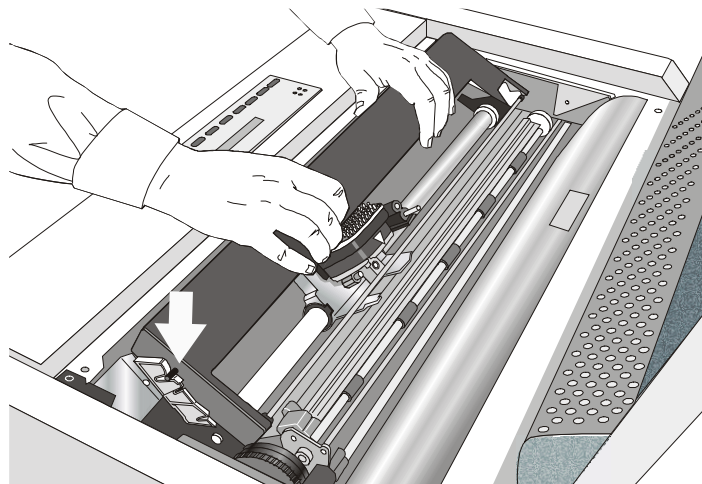

7. Slide and insert the ribbon guide between the print head and the ribbon guide mask holding it perpendicular to the print head.

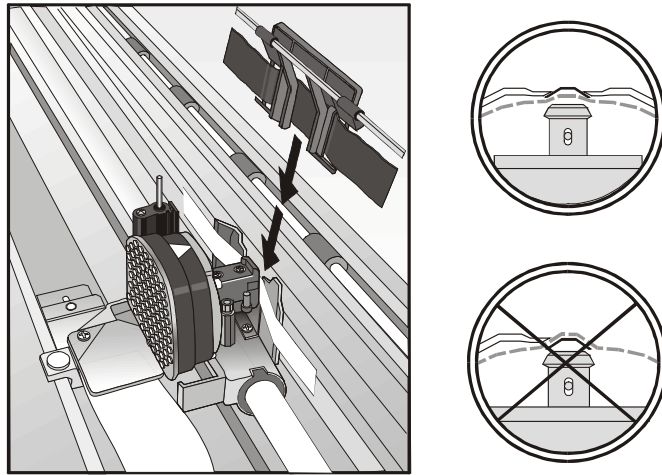

Make sure that the ribbon is inserted correctly between the print head and the print head mask.

8. Insert the shifter holder onto the ribbon shifter as shown in the following figure.

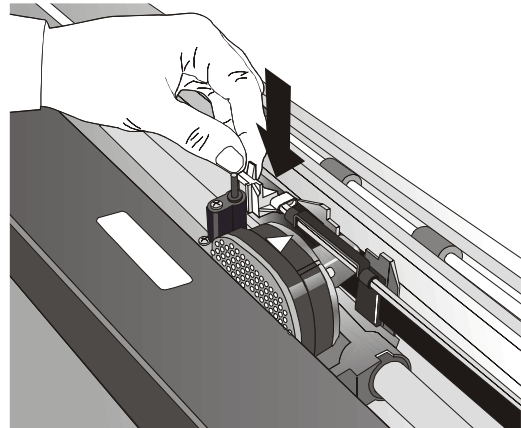

9. Turn again the ribbon-winding knob in the arrow direction (located on the cartridge) to take up slack in the ribbon.
10. Push the cartridge down gently until it clips into place at locking points.

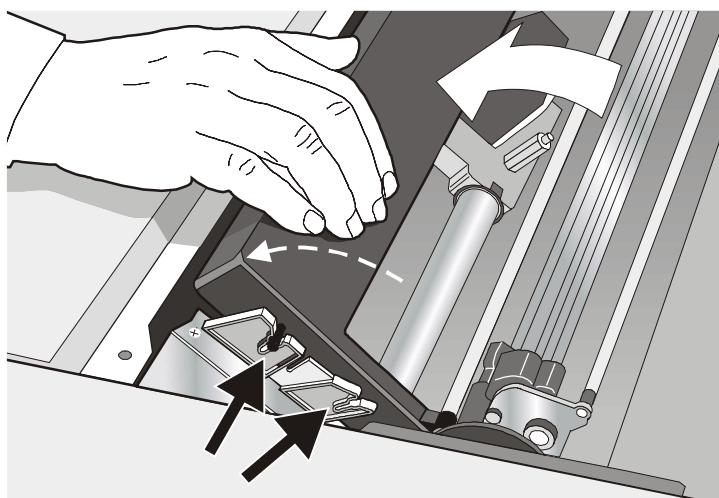

11. Turn the ribbon-winding knob again in the direction of the arrow to take up slack in the ribbon.
12. To ensure that the ribbon guide runs freely along the ribbon, manually move the print carriage horizontally.

If the used ribbon cartridge needs to be replaced, see "[Replacing The Ribbon Cartridge](#)", later in this manual.

Front2 Push Tractor Installation

An additional front push tractor may be installed on the printer. This Front2 push tractor unit is available as an option for the printer model. The Front2 push tractor must be installed on the Front1 push tractor.

1. Find the Front2 push tractor among the accessories.

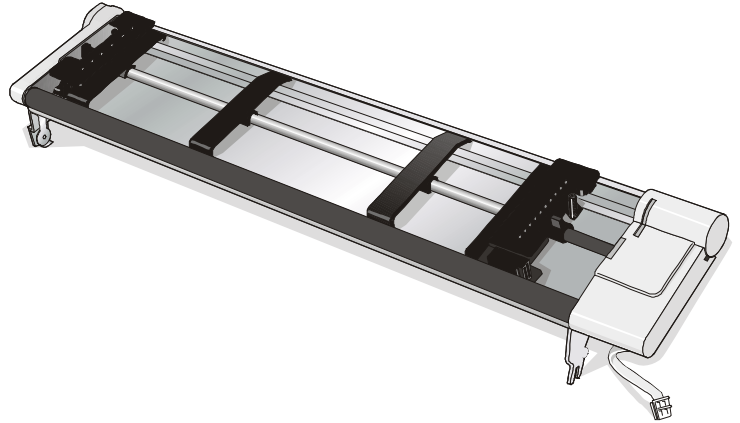

2. Align the hooks on both sides of the Front 2 tractor with the pins on the Front 1 push tractor.

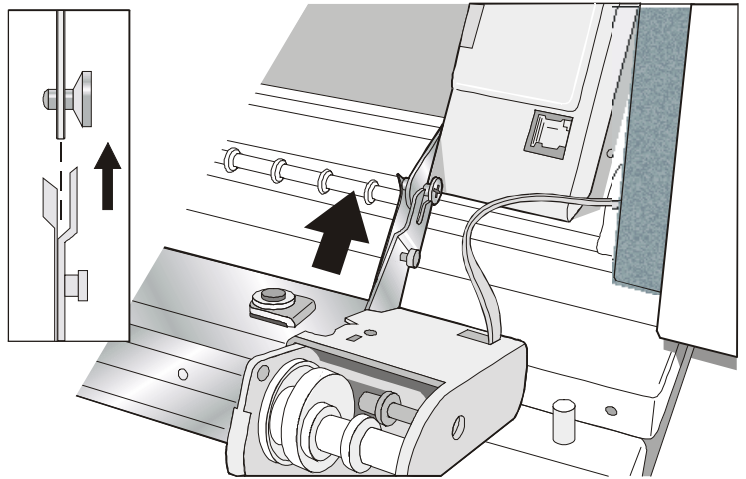

3. Push the Front 2 tractor until it is fully engaged.

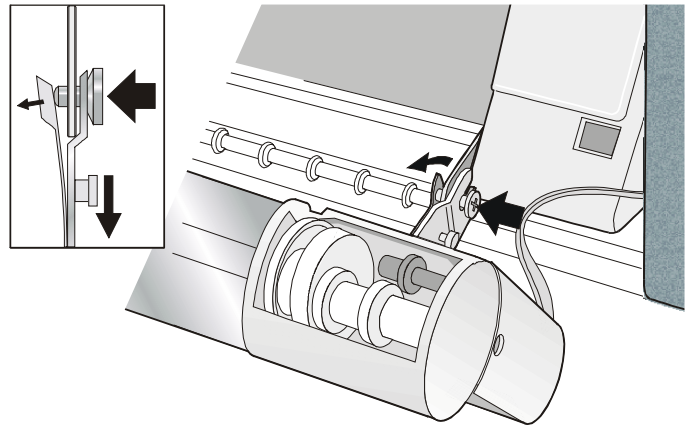

4. Insert the connector cable in the electrical connector located in the lower push tractor.

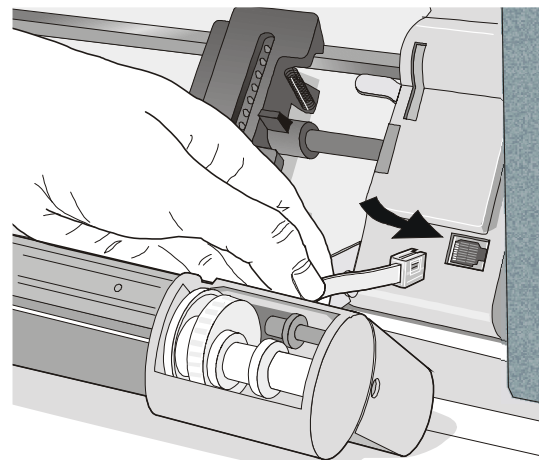

5. Rotate the Front2 push tractor onto the Front 1 push tractor.

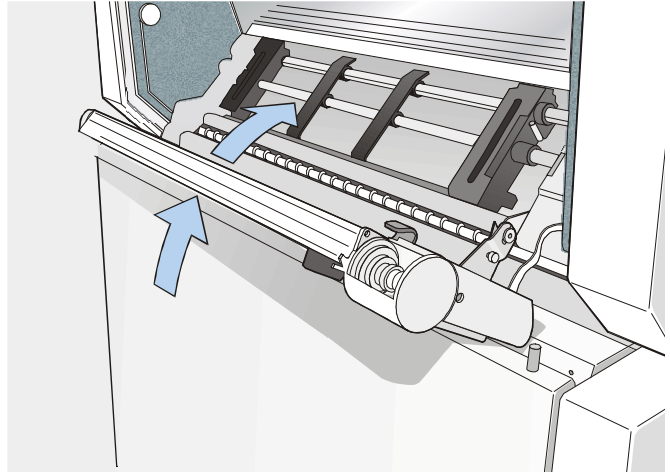

Removing the Front2 Push Tractor

If you need to remove the upper push tractor, turn the printer off. Disconnect the connector cable and press on the push buttons to disengage the Front2 push tractor.

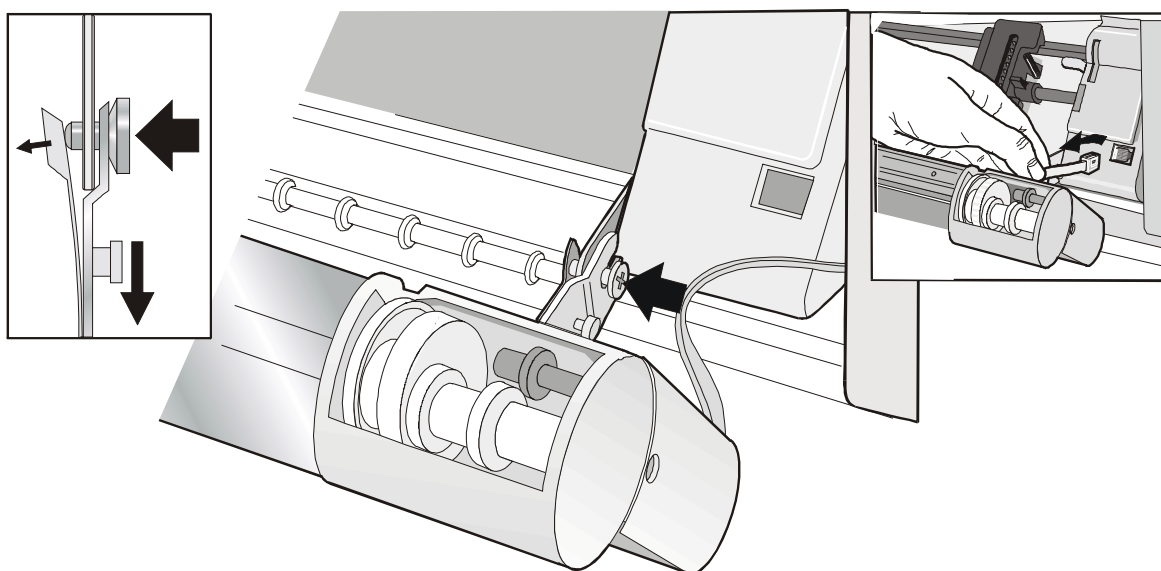

Host Computer Connection

This printer can be connected to your host computer via different available interfaces on two alternative controllers.

Before connecting the interface cable, make sure that the printer and the host computer are turned OFF.

- First Controller: this controller provides the following three interfaces:
 - A bidirectional IEEE1284 parallel interface
 - A RS-232C serial interface
 - An USB interface.
- Second Controller: this controller provides the following two interfaces:
 - A bidirectional IEEE1284 parallel interface
 - An Ethernet LAN interface.

The interface connectors are located on the rear of the printer.

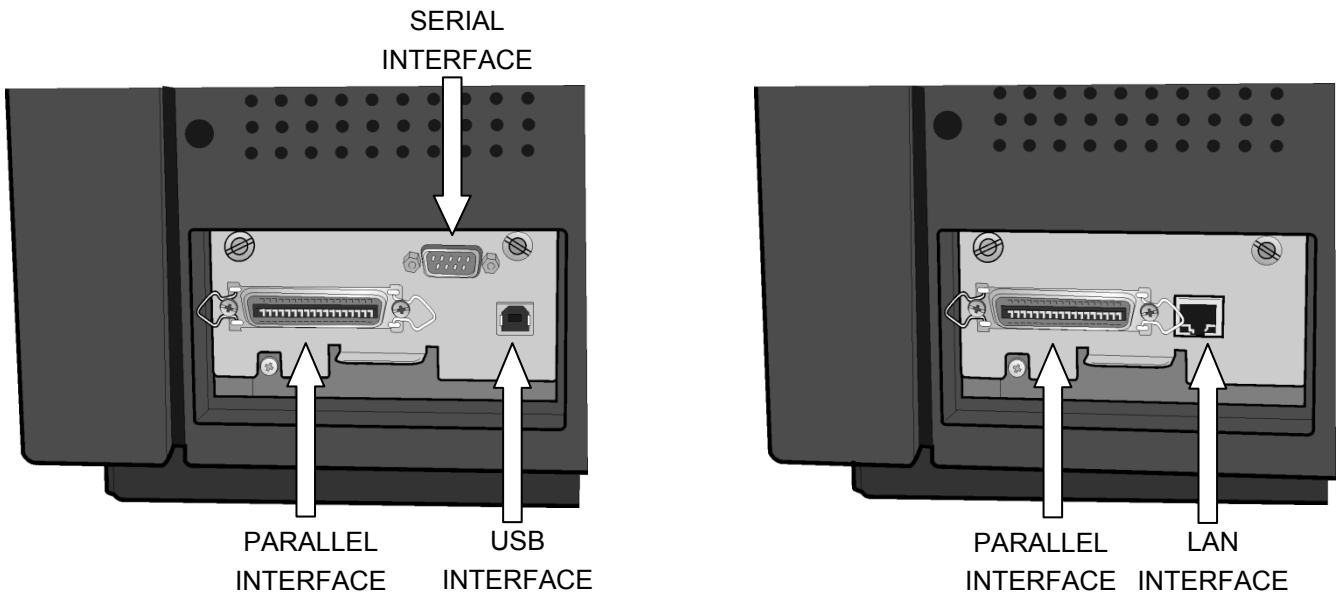

Insert the *parallel interface cable* into the parallel connector and fasten it by means of the clips.
Insert the *serial interface cable* into the serial connector and fasten it by means of the two screws (use the screwdriver).

Insert the *USB interface cable* into the USB connector
Insert the *LAN interface cable* into the LAN connector.

Software Driver Selection

At this point it is necessary to configure your printer for your application package. The installation procedures depend upon the host environment.

Follow the instructions in the *readme* file you find on the CD-ROM.

In a WINDOWS 95/98/2000/XP/NT4.0/Millennium®/Vista environment the printer supports the Plug & Play feature.

**The printer drivers of all Compuprint printers can be found at the Internet Address
<http://www.compuprint.com>**

Power Connection

The power outlet must be compatible with the plug of the printer's power cable.
Always use a grounded outlet.

1. Make sure the power outlet is near the printer location and easily accessible.
2. Make sure that the power switch is in *0* position (OFF).

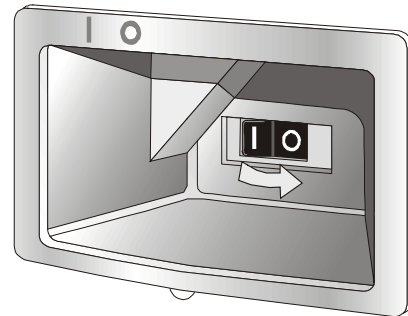

3. Insert the power cable plug into the printer connector and the other power cable end into a convenient outlet (the figure shows the European version).

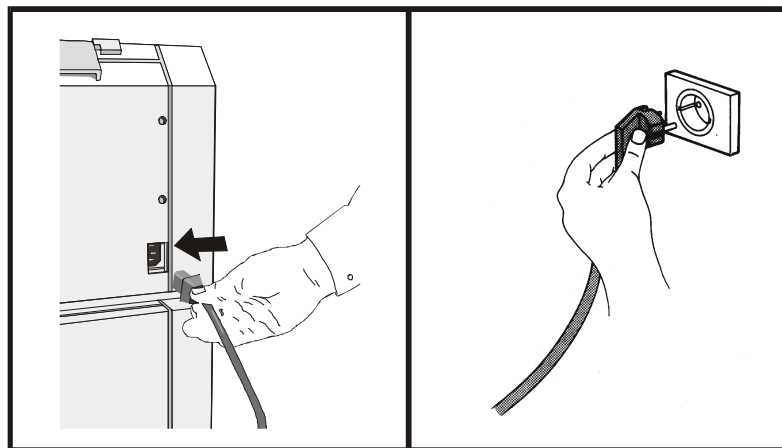

4. If you need to turn the printer on, press the power switch in the *I* position (ON).

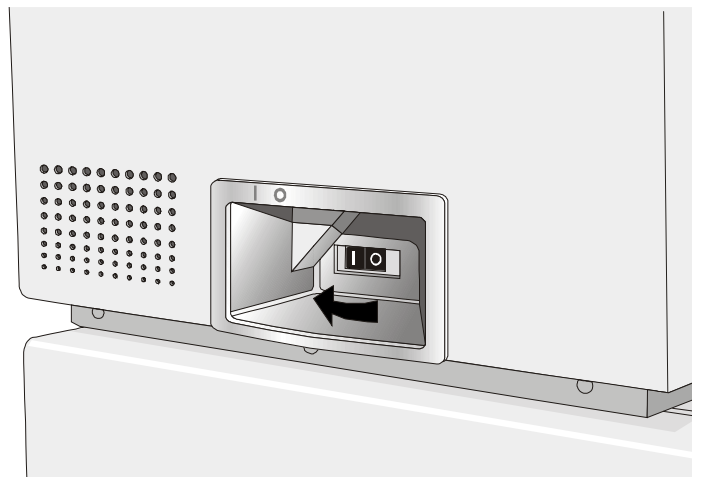

Selecting the Display Language

The display messages for this printer can be displayed in five different languages: English (Default), French, German, Italian and Spanish. To select the language, that you prefer, proceed as follows:

1. Press the PROGRAM key and keep it pressed while powering on the printer until the following message will be displayed:

RELEASE KEYS

2. When you release the PROGRAM key, the following messages will be displayed:

STARTING UP

then,

10300 ver. x.xx

then,

PRINT OUT? NO

3. Press the ↓ key to enter the setup. The first setup item is displayed:

EMUL. OPTIONS

4. Press the ↓ key until the language first level function is displayed:

FUNCTIONS

5. Press the → key to pass to the second level functions:

BUZZER YES

6. Press the ↓ key until the setup language is displayed:

MENU ENGLISH

7. Press the → key to scroll the setup languages. When the desired language is displayed, press the PROGRAM key to select it. The printer exits the setup. From now on the display messages appear in the selected language.

Configuring the Printer

Operator Panel Presentation

The operator panel enables you to perform many of the printer functions including paper path selections, font selection and the printer setup.

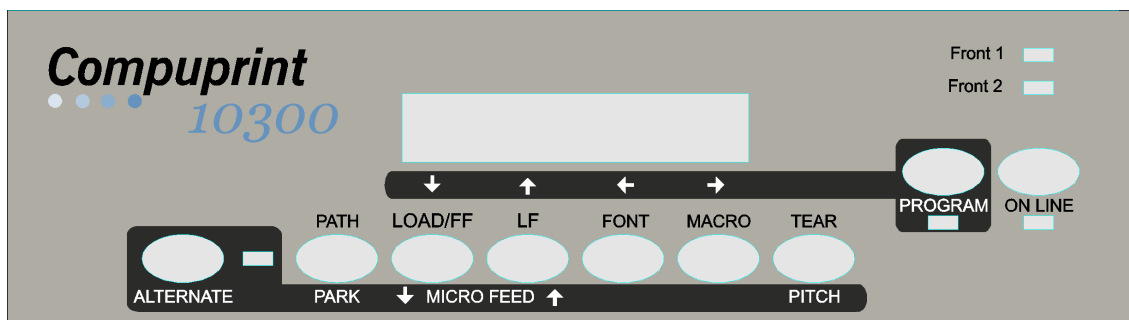

The operator panel consists of:

- A 16 character display (Liquid Crystal Display)
- Five led indicators
- Nine function keys

Display Messages

The printer display is used to indicate the printer status or to request an user intervention. When the printer is in Ready state, the display gives the following information:

- when paper is already loaded and the printer is off line (ON LINE indicator unlit):
- when paper is already loaded and the printer is on line (ON LINE indicator lit):

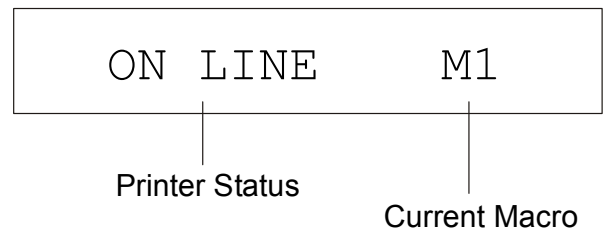
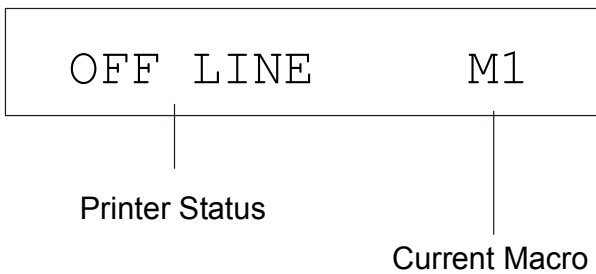

where:

OFF LINE	Indicates the printer status.
ON LINE	

M1, M2, M3, M4	Indicate which of the four User Macros is currently used.
----------------	---

- when there is no paper loaded and the printer is off line (ON LINE indicator unlit):
- when there is no paper loaded and the printer is on line (ON LINE indicator lit):

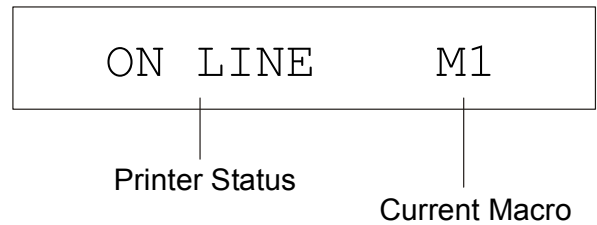
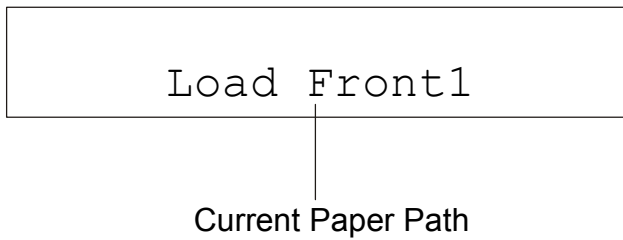

where:

LOAD FRONT1 LOAD FRONT2	Indicates that the currently selected paper path is out of paper. The messages are displayed only for the available paper paths, according to the installed devices.
OFF LINE ON LINE	Indicates the printer status.
M1, M2, M3, M4	Indicate which of the four User Macros is currently used.

The following messages appear to indicate other printer conditions or user intervention requests. The list is in alphabetical order.

Message	Description
ALTERNATE	This message appears to indicate that the Alternate functions of the operator panel keys have been selected pressing the ALTERNATE key.
BUSY M1	This message appears to indicate that the printer is printing. It is busy.
COVER OPEN CLOSE COVER	When the printer cover is not closed correctly, the buzzer sounds and the display shows alternately these two messages. Close the printer cover.
EJECTING	The printer is ejecting the paper out of the printer.
INITIALIZING LAN	This message is displayed when the LAN is initialized (only if the LAN interface is available).
INVALID KEY	This message is displayed if you push a key that is not allowed in the current printer status.
LOAD FRONT1 LOAD FRONT2	These messages are displayed when the corresponding paper path is out of paper. The printer displays only the messages related to the installed devices.
LOCKED MENU	When the access to the Printer Setups has been locked at the power on, the printer displays this message.
MACRO CHANGING	The macro has been changed and the printer is updating the settings.
MICRO FEED DOWN	The paper is fed in microsteps downwards when pressing the ↓ arrow key.

Message	Description
MICRO FEED UP	The paper is fed in microsteps forwards when pressing the ↑ arrow key.
OPER. INTERRUPTED	This message is displayed if the ALTERNATE key has been pressed to interrupt a park procedure.
PARKING	The printer is parking the fanfold paper.
PATH CHANGING	The path has been changed and the printer is updating the settings.
PRESS A KEY NVM CHANGED	The NVM has been changed. Press any key to set the printer.
RELEASE KEYS	This message is displayed when you can release the ON LINE key in the Self-test selection or the PROGRAM key in the Power-on Configuration procedure.
REMOTE CONTROL	This message is displayed when the printer operates from remote control (only if the LAN interface is present).
RESET & BREAK	This message is displayed when the input buffer corresponding to the active interface is cleared.
SELF TEST	Printing the self-test page.
TEAR IF NECESS. EJECT PAPER	These messages are displayed when the printer receives a paper parking command and the TEAR NO item is selected for the tear-off function. Tear off the fanfold then press the PARK key to eject the paper.
TEAR IF NECESS. PARK PAPER	These messages are displayed when the printer receives a paper parking command. Tear off the fanfold paper if necessary and then press the PARK key to park the paper.

Message	Description
TEAR OFF PAPER EJECT PAPER	These messages are displayed when the printer receives a paper ejecting command (TEAR NO item has been selected for the tear-off function) but was not able to execute it, because the paper to be ejected is longer than 18 inch. Tear off the fanfold paper and then press the PARK key to eject the paper.
TEAR OFF PAPER PARK PAPER	These messages are displayed when the printer has received a paper parking command but was not able to execute it, because the paper to be parked is longer than 18 inch. Tear off the fanfold paper and then press the PARK key to park the paper.
UNLOCKED MENU	When the access to the Printer Setups has been unlocked at the power on, the printer displays this message.

For the error messages see "Error Handling" later in this manual.

Indicators



ON LINE

Lit when the printer can receive and print data (printer online).

Blinks when there is data in the buffer and the printer is offline.

Unlit when the printer is disabled and the buffer does not contain any data, or during the initialization, setup or tests.



PROGRAM

Lit when one of the printer setup procedures has been selected: *Program Configuration* or *Power-On Configuration*.



ALTERNATE

Lit when the alternate function of the keys has been enabled pressing the ALTERNATE key.



Front 1

Lit when the Front1 paper path is selected.

Unlit when the Front1 paper path is not selected.



Front 2

Lit when the Front2 paper path is selected.

Unlit when the Front2 paper path is not selected.



Attention Light

Lit when the printer can receive and print data (the printer is on-line).

Unlit when the printer is disabled (the printer is off-line).

Blinks when an error condition occurs.

Function Keys

Pressing the function keys it is possible to activate the functions indicated by the word or symbol signed near the key. Each key may have different functions, according to the selected function modes: *Normal*, *Alternate* or *Program*.

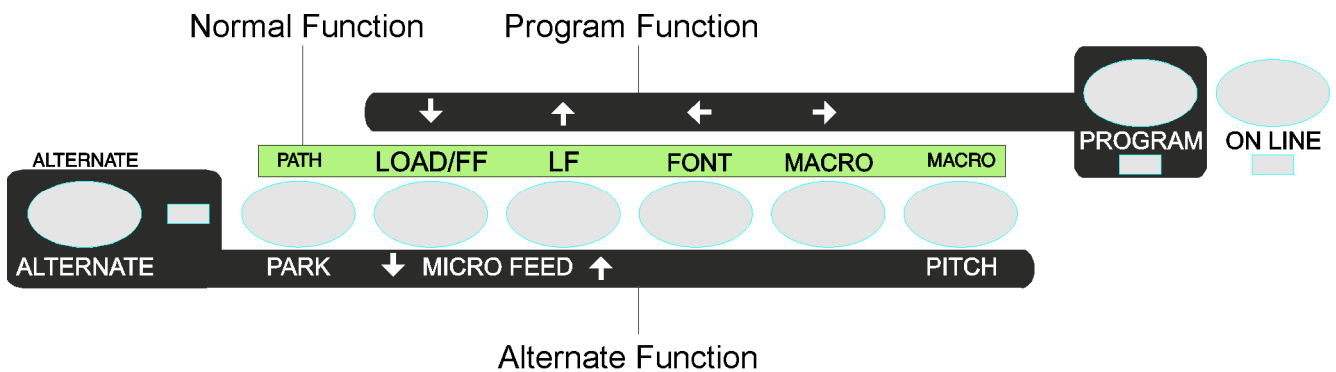

- Normal Function** The *normal* function of the keys is written above the keys and does not require any previous action to select it.
- Alternate Function** The *alternate* function of the keys is written below the keys and is selected pressing the ALTERNATE key. When the alternate function of the keys is selected, the ALTERNATE indicator is lit and the display shows ALTERNATE.
- Program Function** The *program* function of the keys is selected pressing the PROGRAM key, where:
- If you press the key while powering the printer on, the *Power-On Configuration* is selected.
 - If you press the key when the printer is enabled without printing or disabled (ON LINE indicator unlit), the *Program Setup* is selected.
- In the Program Setup mode only the four arrow keys and the PROGRAM key are enabled and the PROGRAM indicator is lit.

ON LINE Key

ON LINE	Normal Function	Enables or disables the printer. <ul style="list-style-type: none">• If this key is pressed while powering the printer on, the self test is printed; the printout is stopped pressing this key again.• In an error condition, once the error cause has been removed, press this key to enable the printer
	Program Function	Pressing this key, the input buffer is cleared. The message RESET & BREAK is displayed.

PROGRAM Key

PROGRAM	Normal Function	Enables the printer setups as follows: <ul style="list-style-type: none">• Pressing this key while powering on the printer, the <i>Power-On Configuration</i> is selected.• Pressing this key when the printer is enabled without printing or disabled the <i>Program Setup</i> is enabled (PROGRAM indicator lit).
	Program Function	Exits the printer setups.

MACRO Key

MACRO	Normal Function	Selects one of the user macros (Macro 1, Macro 2, Macro 3 or Macro 4). If you want to select the displayed macro, wait for 2 seconds without pressing any key and the parameters of this macro will be set.
→	Program Function	Scrolls the parameters of the functions or macros forwards.

FONT Key

FONT	Normal Function	Selects the font to be used with the currently selected pitch. The selected font is valid until the printer is turned off or a new font is selected using this key.
←	Program Function	Scrolls the parameters of the functions or macros backwards.

LF Key

LF	Normal Function	Performs a line feed according to the current line spacing settings.
MICRO FEED	Alternate Function	Moves the paper forward in microsteps. Keeping the key pressed the paper is moved continuously at increasing speed.
↑	Program Function	Scrolls the setup and macro functions backwards.

LOAD/FF Key

LOAD/FF	Normal Function	Executes a Form Feed (FF). When paper is loaded into the printer, it advances to the following page; if no paper is loaded, it is positioned for printing.
MICRO FEED	Alternate Function	Moves the paper backward in microsteps. Keeping the key pressed the paper is moved continuously at increasing speed.
↓	Program Function	Scrolls the setup and macro functions forwards.

ALTERNATE Key

ALTERNATE	Normal Function	<p>Enables the alternative key functions.</p> <p>If the printer is receiving print data, press the ON LINE key before pressing the ALTERNATE key.</p> <p>If no printing data are in the print buffer, pressing the ALTERNATE key, the printer goes offline.</p> <p>The display then shows ALTERNATE to indicate that the Alternate Function of the keys is enabled (ALTERNATE indicator lit).</p> <p>May be used to abort paper parking procedure. See also "How to Handle the Paper Parking", later in this manual.</p> <p>When the printer is in Program Setup Mode, this key is disabled.</p>
	Alternate Function	<p>Disables the alternative key functions.</p>

TEAR/PITCH Key

TEAR	Normal Function	<p>Moves the paper to the tear-off position (TEAR NORMAL function must be selected in the <i>Program Setup</i>).</p>
PITCH	Alternate Function	<p>Selects the pitch to be used with the currently selected font. The selected pitch is valid until the printer is turned off.</p>

PATH/PARK Key

PATH	Normal Function	Selects one of the paper paths in offline status. The parameters of the displayed path are set after 2 seconds without pressing any key.
PARK	Alternate Function	Parks the paper in the currently selected paper path.

Key Combinations

ONLINE + MACRO + TEAR	Normal Function	Lock or unlock the access to the printer setups. See later “How to Lock/Unlock the Printer Setups” section.
-----------------------	-----------------	---

Printer Setups

The main printer setup parameters can be selected via the operator panel. The setup parameters are divided into two printer setups, the *Power-On Configuration*, that allows a complete configuration at installation time according to the hardware and the emulation types, and the *Program Setup*, that allows you to set the functions that are the most useful in your daily job. These settings can be selected when the printer is online without printing or offline (ON LINE indicator unlit) and stored in the NVM.

Entering the Printer Setups

- Press the PROGRAM key and keep it pressed at the printer power on until the RELEASE KEYS message is displayed to select the *Power-On Configuration*.
- Press the PROGRAM key when the printer is online without printing or offline (ON LINE indicator unlit) to select the *Program Setup*.

Moving within the Printer Setups

The arrow keys ↑, ↓, ←, → are used to move within the different functions inside the Printer Setups. See the following description of the setup items.

Leaving the Printer Setups

- Pressing the PROGRAM key in the *Power-On Configuration* the printer exits from the setup and the new settings will be automatically saved.
- Pressing the PROGRAM key in the *Program Setup*, the following choice is offered for the storage of the values set:

STORE? QUIT	The new settings are not activated and the old settings remain valid.
STORE? SAVE	The new settings are stored permanently in the NVM (Non Volatile Memory).
STORE? CURRENT	The new settings remain valid until the printer is turned off.

Press the → or ← keys to scan these selections forward and backwards. When the desired setting is displayed, press the PROGRAM key to exit from the Setup.

Power-On Configuration

The default values of the various functions are indicated in bold.

Entering the Power-On Configuration

1. Make sure that the printer is turned off.
2. Press and hold the PROGRAM key pressed while powering on the printer until the `RELEASE KEYS` message is displayed. As soon as the PROGRAM key gets released, the following message will be displayed:

then,

STARTING UP

then,

10300 ver. x.xx

PRINT OUT? NO

Main Structure

This figure shows the structure of the *Power-On Configuration* and how to move inside the Setup.

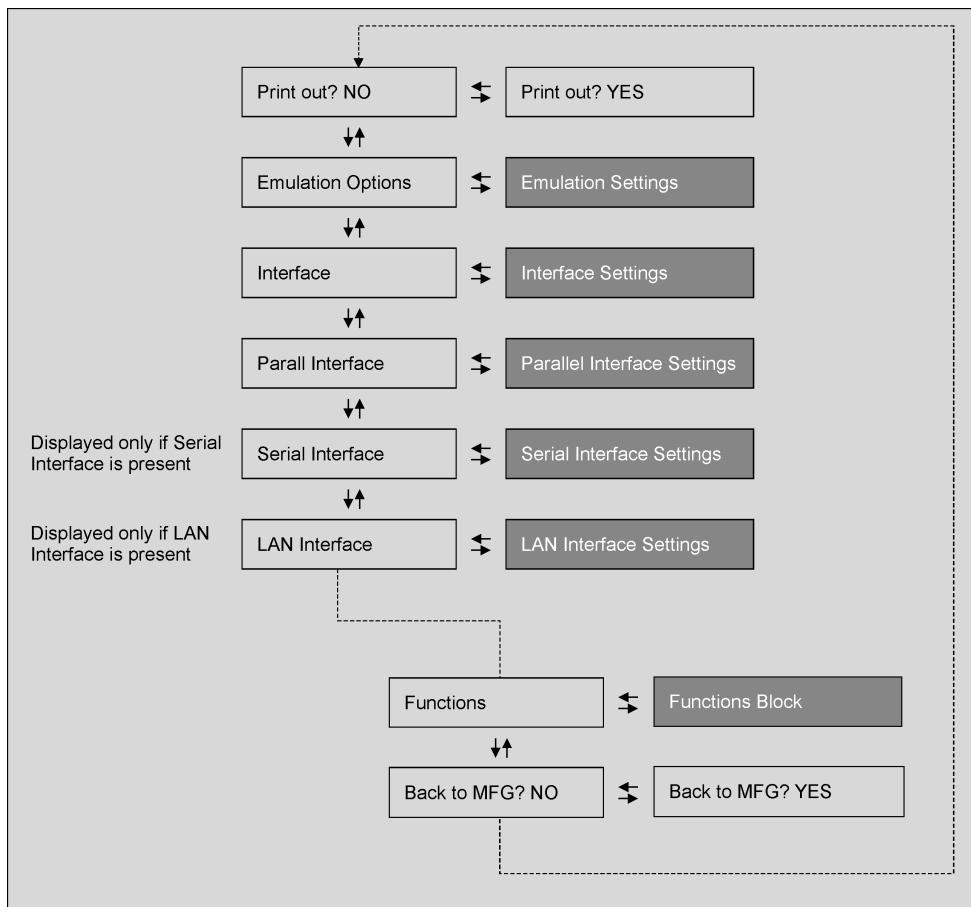

The setup item `Functions` groups the following printer functions:

- Buzzer setting,
- Paper loading sequence,
- Bar code density,
- Text printing direction,
- Graphics printing direction,
- Bar code printing direction,
- Graphics printing speed,
- Paper path at power on,
- Language of the display messages,
- Paper tractor jam sensors,
- Tear-off position adjustment.

Printout of the Printer Settings

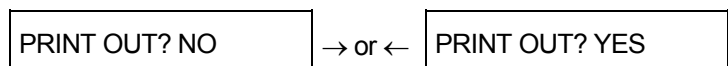

EMUL. OPTIONS

PRINT OUT? NO The Setup is not printed.

PRINT OUT? YES The printer setup is printed showing the currently selected values. The printout starts as soon as you select this value.

Emulation Options

This setup defines the available options according to the selected emulation and is structured as follows:

Options

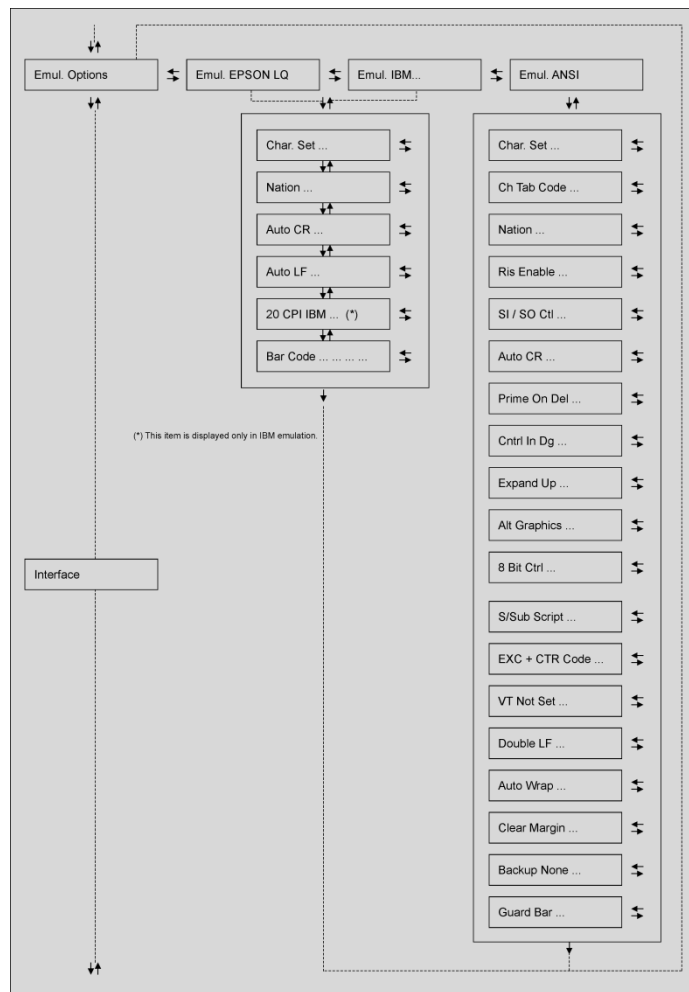

Setting the Emulation Options

Printer Emulation

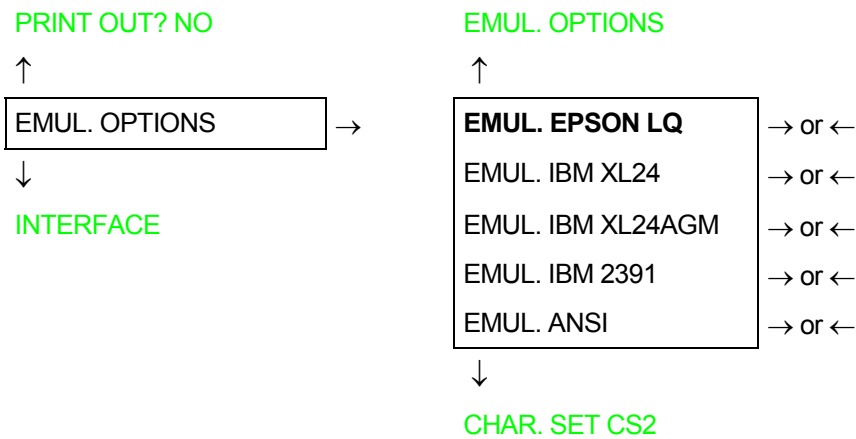

EMUL EPSON LQ	The printer uses the EPSON LQ Series emulation.
EMUL IBM XL24	The printer uses the IBM Proprinter XL24 emulation.
EMUL IBM XL24AGM	The printer uses the IBM Proprinter XL24 AGM emulation.
EMUL. IBM 2391	The printer uses the IBM Personal 2391+ emulation.
EMUL. ANSI	The printer uses the ANSI 3.64 emulation.

If ANSI emulation has been selected, specific ANSI parameters are available. See the “[ANSI options](#)” section later in this manual.

EPSON Character Sets

EMUL. EPSON LQ

↑

CHAR. SET CS1	→ or ←
CHAR. SET CS2	→ or ←
CHAR. SET ITALIC	→ or ←

↓

NATION CP437

These items select the character set to be used in EPSON emulation.

IBM Character sets

EMUL. IBM xxx

↑

CHAR. SET CS1	→ or ←
CHAR. SET CS2	→ or ←

↓

NATION CP437

These items select the character set to be used in IBM Proprinter emulation.

EPSON National Character sets

CHAR. SET CS2

↑

NATION CP437	→ or ←
NATION ...	→ or ←
NATION LATIN A1	→ or ←

↓

AUTO CR YES

The following national character sets are available:

CP 437	CP437 G	96GREEK	CP850	CP851	CP 852	CP 853	CP 855
CP 857	CP 858	CP 860	CP 862	CP 863	CP 864	CP 865	CP 866
CP 867	CP 876	CP 877	CP 1250	CP 1251	CP 1252	CP 1253	CP 1254
CP 1255	CP 1256	CP 1257	GOST	TASS	MAZOWIA	ISO 8859/1	ISO 8859/2
ISO 8859/3	ISO 8859/4	ISO 8859/5	ISO 8859/6	ISO 8859/7	ISO 8859/8	ISO 8859/9	ISO 8859/15
CP 437SL	CP 1098	UKRAIN	KOI8-U	FARSI1	FARSI2	USA	FRANCE
GERMANY	ENGLAND	DENMARK1	SWEDEN	ITALY	SPAIN1	JAPAN	NORWAY
DENMARK2	SPAIN2	LATIN A1					

The CP 858 and ISO 8859/15 character sets contain the Euro character.

IBM National Character Sets

CHAR. SET CS2

↑

NATION CP437	→ or ←
NATION ...	→ or ←
NATION FARSI2	→ or ←

↓

AUTO CR NO

The following national character sets can be selected:

CP 437	CP437 G	96GREEK	CP850	CP851	CP 852	CP 853	CP 855
CP 857	CP 858	CP 860	CP 862	CP 863	CP 864	CP 865	CP 866
CP 867	CP 876	CP 877	CP 1250	CP 1251	CP 1252	CP 1253	CP 1254
CP 1255	CP 1256	CP 1257	GOST	TASS	MAZOWIA	ISO 8859/1	ISO 8859/2
ISO 8859/3	ISO 8859/4	ISO 8859/5	ISO 8859/6	ISO 8859/7	ISO 8859/8	ISO 8859/9	ISO 8859/15
CP 437SL	CP 1098	UKRAIN	KOI8-U	FARSI1	FARSI2		

The CP 858 and ISO 8859/15 character sets contain the Euro character.

CR Code Behavior

NATION xxx

↑

AUTO CR NO	→ or ←
AUTO CR YES	→ or ←

↓

AUTO LF NO

AUTO CR NO No automatic carriage return is performed after a LF, VT or ESCJ code.
Default value in IBM emulation.

AUTO CR YES The printer performs an automatic carriage return after a LF, VT or ESCJ code.
Default value in EPSON emulation.

LF Code Behavior

AUTO CR xx

↑

AUTO LF NO	→ or ←
AUTO LF YES	→ or ←
AUTO LF HOST	→ or ←

↓

20 CPI IBM NO

or

BAR CODE NATIV

AUTO LF NO No Automatic LF after CR.

AUTO LF YES Automatic LF after CR.

AUTO LF HOST Only in EPSON emulation. The printer checks the AUTOFEEDXT signal coming from the host and executes an automatic LF after CR, if the signal is low.

IBM Compressed Printing

These items are displayed only if the IBM emulation is selected.

AUTO LF NO

↑

20 CPI IBM NO	→ or ←
20 CPI IBM YES	→ or ←

↓

BAR CODE NATIV

20 CPI IBM NO The compressed printing is performed at 17.1 cpi.

20 CPI IBM YES The compressed printing is performed at 20 cpi.

Bar code mode

20 CPI IBM NO

or

AUTOLF NO

↑

BAR CODE NATIV

→ or ←

BAR CODE ALTER

→ or ←

↓

EMUL. OPTIONS

BAR CODE NATIV Enables bar code printing using the native commands (DC4, DC4, ...).

BAR CODE ALTER Enables bar code printing using ANSI commands even if the emulation in use is EPSON or IBM.

Interface Settings

Depending upon the installed Controller Board, the printer can be equipped with different interfaces to connect to the host system. The possible interfaces are:

- Parallel Centronics
- Serial 232C
- USB
- Ethernet LAN 10/100

The following paragraphs describe how to configure the parameters of the interfaces.

Interface

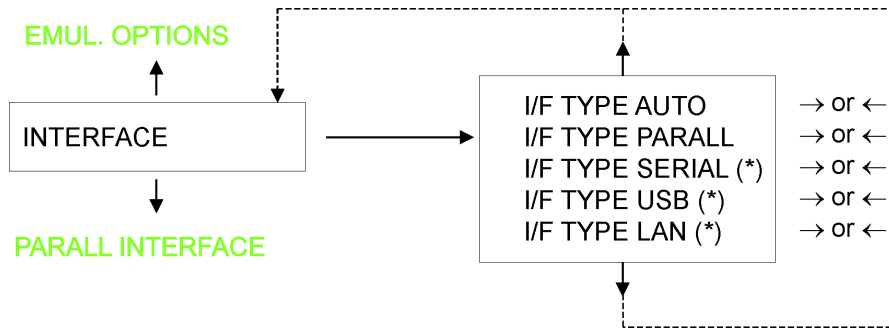

(*) This item is displayed only if the interface board (Controller Board) installed on the unit is equipped with this interface.

AUTO	All the interfaces installed onto the interface board (controller) are active and the hot port feature is operative.
PARALLEL	Only the Centronics Parallel Interface is active. Hot Port is not operative.
SERIAL	Only the Serial RS232 Interface is active. Hot Port is not operative.
USB	Only the USB Interface is active. Hot Port is not operative.
LAN	Only the Ethernet LAN Interface is active. Hot Port is not operative.

Parallel Interface

This setup defines the use of the parallel interface and is structured according to the interface specific parameters.

Parallel Interface Parameters

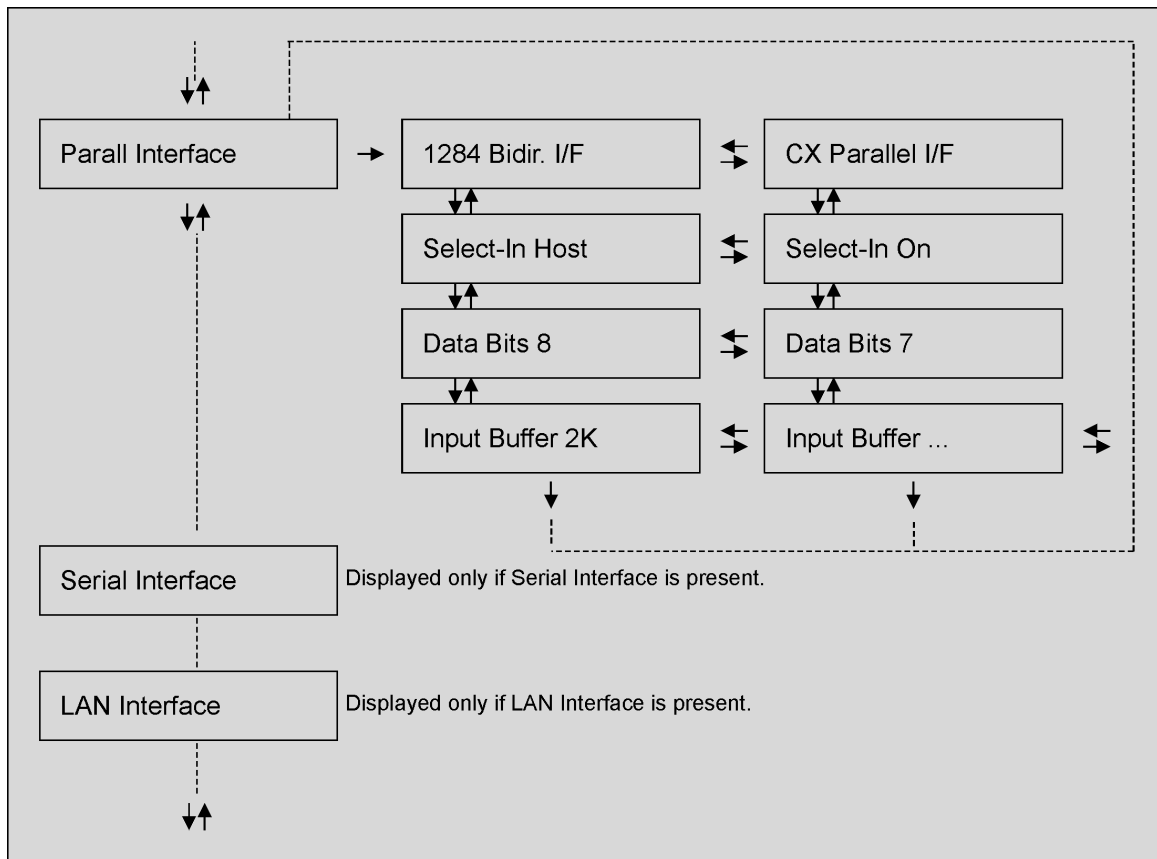

Setting the Parallel Interface Parameters

Interface Type

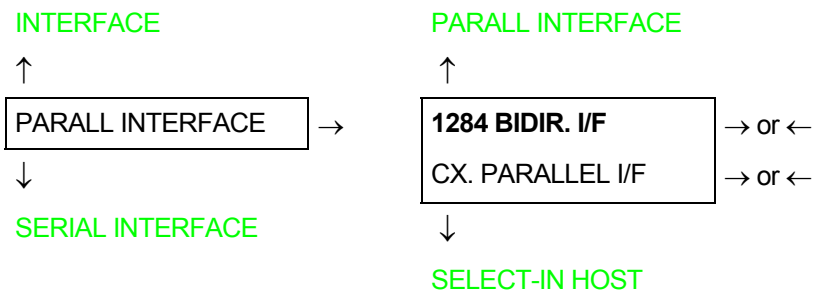

1284 BIDIR. I/F Bidirectional IEEE 1284 parallel interface.

CX. PARALLEL I/F Centronics type parallel interface (mono-directional).

Setting the Select-In Signal

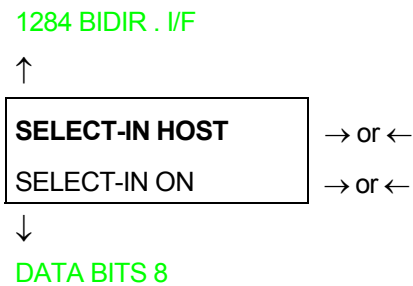

SELECT-IN HOST The printer checks the SELECT-IN signal coming from the host.

SELECT-IN ON The SELECT-IN signal of the parallel interface is ignored and treated always as ON.

Number of Data Bits

SELECT-IN HOST

↑

DATA BITS 8	→ or ←
DATA BITS 7	→ or ←

↓

INP. BUFFER 2K

Selection of the number of data bits: 7 or 8.

Input Buffer Size

DATA BITS 8

↑

INP. BUFFER 256	→ or ←
INP. BUFFER 2K	→ or ←
INP. BUFFER 12K	→ or ←
INP. BUFFER 32K	→ or ←
INP. BUFFER 64K	→ or ←
INP. BUFFER 128K	→ or ←

↓

PARALL. INTERFACE

Selects the input buffer size.

Serial Interface

The following Serial Interface Parameters will display only if the Serial Interface is present.

This setup defines the use of the serial interface and is structured according to the interface specific parameters.

Serial Interface Parameters

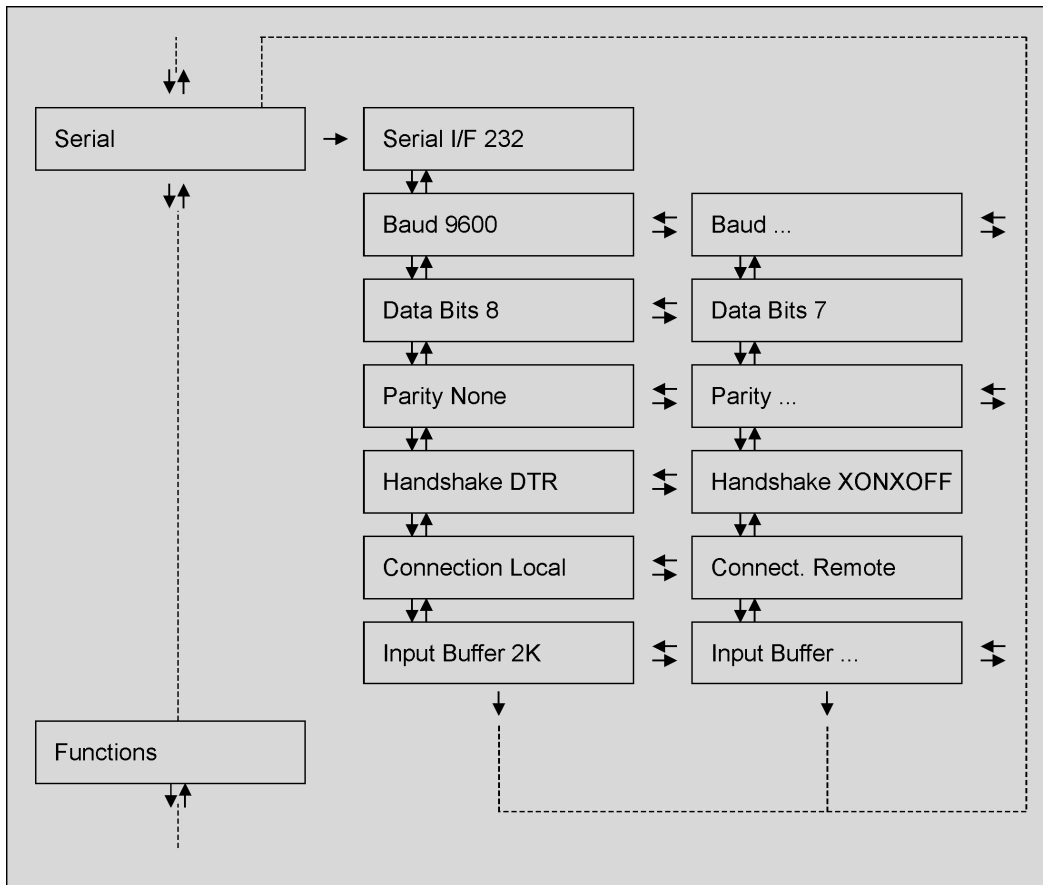

Setting the Serial Interface Parameters

Interface Type

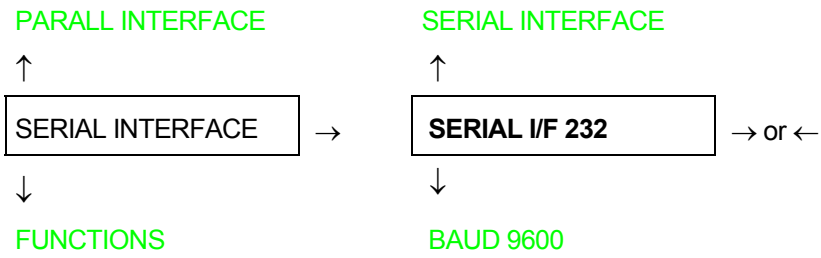

SERIAL I/F 232

It is available the serial interface RS-232/C only.

Baud Rate

SERIAL I/F 232

↑

BAUD 300	→ or ←
BAUD 600	→ or ←
BAUD 1200	→ or ←
BAUD 2400	→ or ←
BAUD 4800	→ or ←
BAUD 9600	→ or ←
BAUD 19200	→ or ←
BAUD 38400	→ or ←
BAUD 115200	→ or ←

↓

DATA BITS 8

The baud rate is selected in bits per second. The above values can be selected.

Number of Data Bits

BAUD 9600

↑

DATA BITS 8	→ or ←
DATA BITS 7	→ or ←

↓

PARITY NONE

Selection of the number of data bits: 7 or 8.

Parity Check

DATA BITS 8

↑

PARITY NONE	→ or ←
PARITY ODD	→ or ←
PARITY EVEN	→ or ←
PARITY MARK	→ or ←
PARITY SPACE	→ or ←

↓

HANDSHAKE DTR

PARITY NONE	Data does not have a parity bit, i.e. 8 bit data are transferred and the parity check is disabled.
PARITY ODD	Parity check is enabled for odd parity.
PARITY EVEN	Parity check is enabled for even parity.
PARITY MARK	Parity check is disabled and the transmitted parity bit is always a Mark.
PARITY SPACE	Parity check is disabled and the transmitted parity bit is always a Space.

Handshake Protocol

PARITY NONE

↑

HANDSHAKE DTR	→ or ←
HANDSHAKE XONXOF	→ or ←

↓

CONNECTION LOCAL

HANDSHAKE DTR The Handshake is performed using the DTR Protocol.

HANDSHAKE XONXOF The Handshake is performed using the XON-XOFF Protocol.

Connection Type

HANDSHAKE DTR

↑

CONNECTION LOCAL	→ or ←
CONNECT. REMOTE	→ or ←

↓

INP. BUFFER 2K

Selects the connection type: local or remote.

Input Buffer Size

CONNECTION LOCAL

↑

INP. BUFFER256	→ or ←
INP. BUFFER 2K	→ or ←
INP. BUFFER12K	→ or ←
INP. BUFFER32K	→ or ←
INP. BUFFER64K	→ or ←
INP. BUFFER128K	→ or ←

↓

SERIAL INTERFACE

Selects the input buffer size.

LAN Interface

The following LAN interface parameters will display only if the Ethernet 10/100 Mbit interface is present.

This setup defines the use of the LAN interface and is structured according to the interface specific parameters.

LAN Interface Parameters

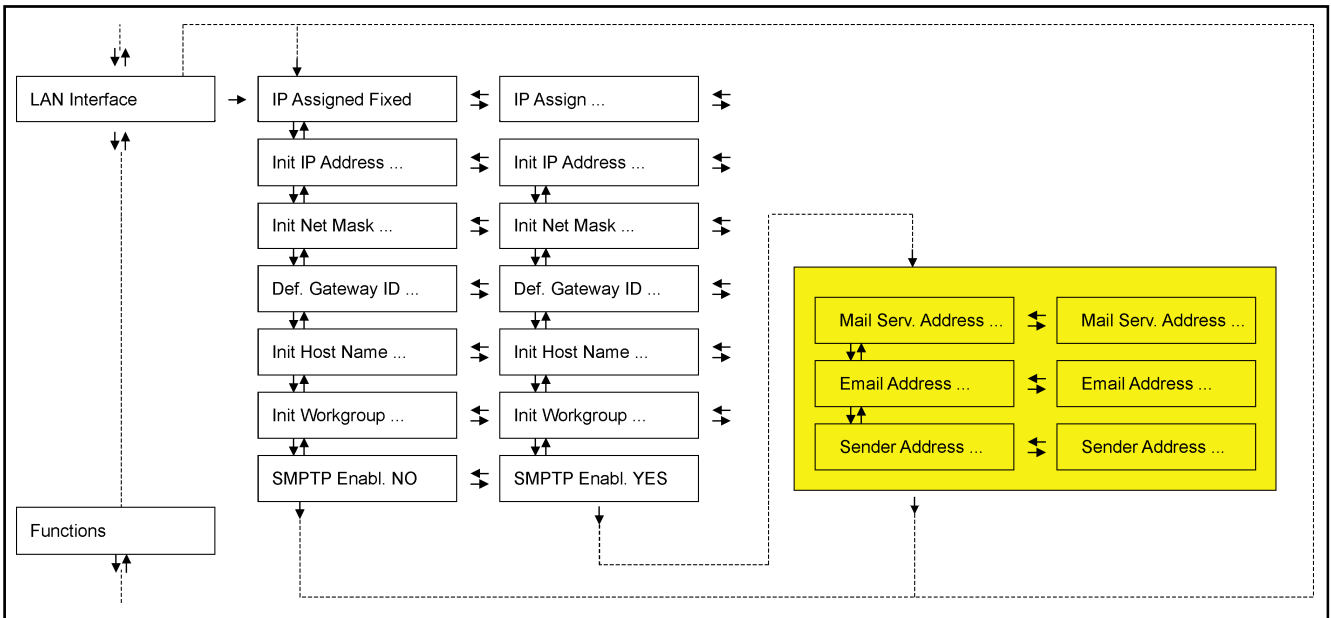

IP Assignment

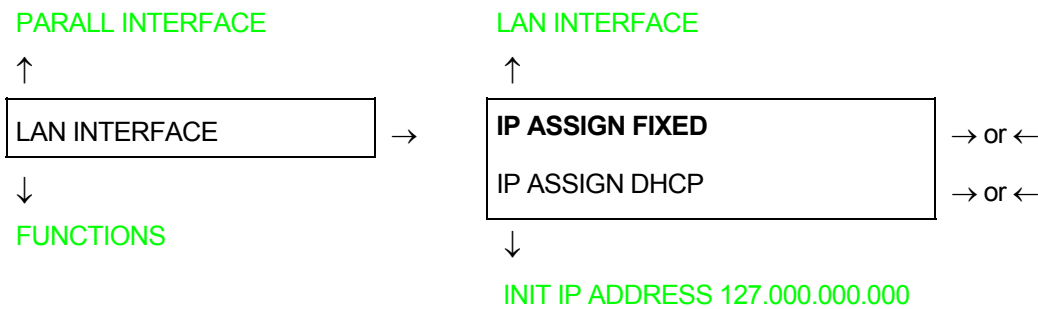

IP ASSIGN FIXED Assigns the static or fixed IP address.

IP ASSIGN DHCP Assigns the dynamic IP address (DHCP protocol).

Init IP Address

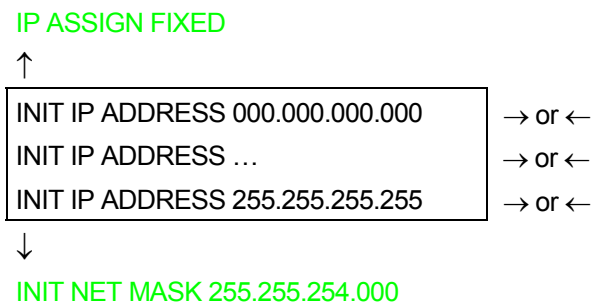

These values set the INIT IP address. The IP address is represented by a decimal notation where the decimal values are divided by points in four fields. Each field ranges between 0 and 255. Use the ← or → keys to increase or decrease the values in one field and the ↓ or ↑ keys to move to the next field (↓ to move to the right and ↑ to move to the left). The default value is 127.000.000.000.

Init Net Mask

INIT IP ADDRESS 127.000.000.000

↑

INIT NET MASK 000.000.000.000	→ or ←
INIT NET MASK ...	→ or ←
INIT NET MASK 255.255.255.255	→ or ←

↓

DEF. GATEWAY ID 000.000.000.000

These values set the INIT net mask number. This number is represented by a decimal notation where the decimal values are divided by points in four fields. Each field ranges between 0 and 255. Use the ← or → keys to increase or decrease the values in one field and the ↓ or ↑ keys to move to the next field (↓ to move to the right and ↑ to move to the left). The default value is **255.255.254.000**.

ID Default Gateway

INIT NET MASK 255.255.254.000

↑

DEF. GATEWAY ID 000.000.000.000	→ or ←
DEF. GATEWAY ID ...	→ or ←
DEF. GATEWAY ID 255.255.255.255	→ or ←

↓

INIT HOST NAME CMP_XXXXXX

These values set the ID default gateway number. This number is represented by a decimal notation where the decimal values are divided by points in four fields. Each field ranges between 0 and 255. Use the ← or → keys to increase or decrease the values in one field and the ↓ or ↑ keys to move to the next field (↓ to move to the right and ↑ to move to the left).

Init Host Name

DEF. GATEWAY ID 000.000.000.000

↑

INIT HOST NAME → or ←

PROGRAM key

↓

INIT WORKGROUP CMP_GROUP

The host is identified by a name. This function allows to create the name of the init host using a 14-character string. Use the ← or → keys to increase or decrease the values in one field and the ↓ or ↑ keys to move to the next field (↓ to move to the right and ↑ to move to the left). Press the PROGRAM key to save the selected init host name. The default name is CMP_XXXXXX.

Init Workgroup Name

INIT HOST NAME CMP_XXXXXX

↑

INIT WORKGROUP → or ←

PROGRAM key

↓

SMTP ENABL. NO

The workgroup is identified by a name. This function allows to create the name of the workgroup using a 14-character string. Use the ← or → keys to increase or decrease the values in one field and the ↓ or ↑ keys to move to the next field (↓ to move to the right and ↑ to move to the left). Press the PROGRAM key to save the selected init workgroup name. The default name is workgroup.

Enable/Disable the SMTP Service

INIT WORKGROUP workgroup



SMTP ENABL. NO → or ← SMTP ENABL. YES



LAN INTERFACE

MAIL SERV.ADDRES 000.000.000.000

SMTP ENABL. NO Disables the SMTP (Simple Mail Transfer Protocol) service, that is disables the reception/transfer/error service of the e-mail.

SMTP ENABL. YES Enables the SMTP (Simple Mail Transfer Protocol) service, that is enables the reception/transfer/error service of the e-mail.

Mail Server Address

This item is displayed only if the SMTP ENABL. function is selected in YES.

SMTP ENABL. YES



MAIL SERV.ADDRES 000.000.000.000 → or ←
MAIL SERV.ADDRES ... → or ←
MAIL SERV.ADDRES 255.255.255.255 → or ←



EMAIL ADDRESS 000.000.000.000

These values set the mail server address. This number is represented by a decimal notation where the decimal values are divided by points in four fields. Each field ranges between 0 and 255. Use the ← or → keys to increase or decrease the values in one field and the ↓ or ↑ keys to move to the next field (↓ to move to the right and ↑ to move to the left).

E-mail Address

This item is displayed only if the SMTP ENABL. function is selected YES.

MAIL SERV.ADDRES 000.000.000.000

↑

EMAIL ADDRESS xxxxxxxxxxxx → or ←

↓

SENDER ADDRESS xxxxxxxxxxxx

This function allows to write the e-mail address where you can notify the failures. Use the ← or → keys to increase or decrease the values in one field and the ↓ or ↑ keys to move to the next field (↓ to move to the right and ↑ to move to the left). Press the PROGRAM key to save the e-mail address.

Sender Address

This item is displayed only if the SMTP ENABL. function is selected YES.

EMAIL ADDRESS xxxxxxxxxxxx

↑

SENDER ADDRESS xxxxxxxxxxxx → or ←

↓

LAN INTERFACE

This function identifies the address of the sender's e-mail using a string of characters. Use the ← or → keys to increase or decrease the values in one field and the ↓ or ↑ keys to move to the next field (↓ to move to the right and ↑ to move to the left). Press the PROGRAM key to save the sender's e-mail address.

Functions

This item groups various printer functions, with which you can configure the printer.

Functions Group Parameters

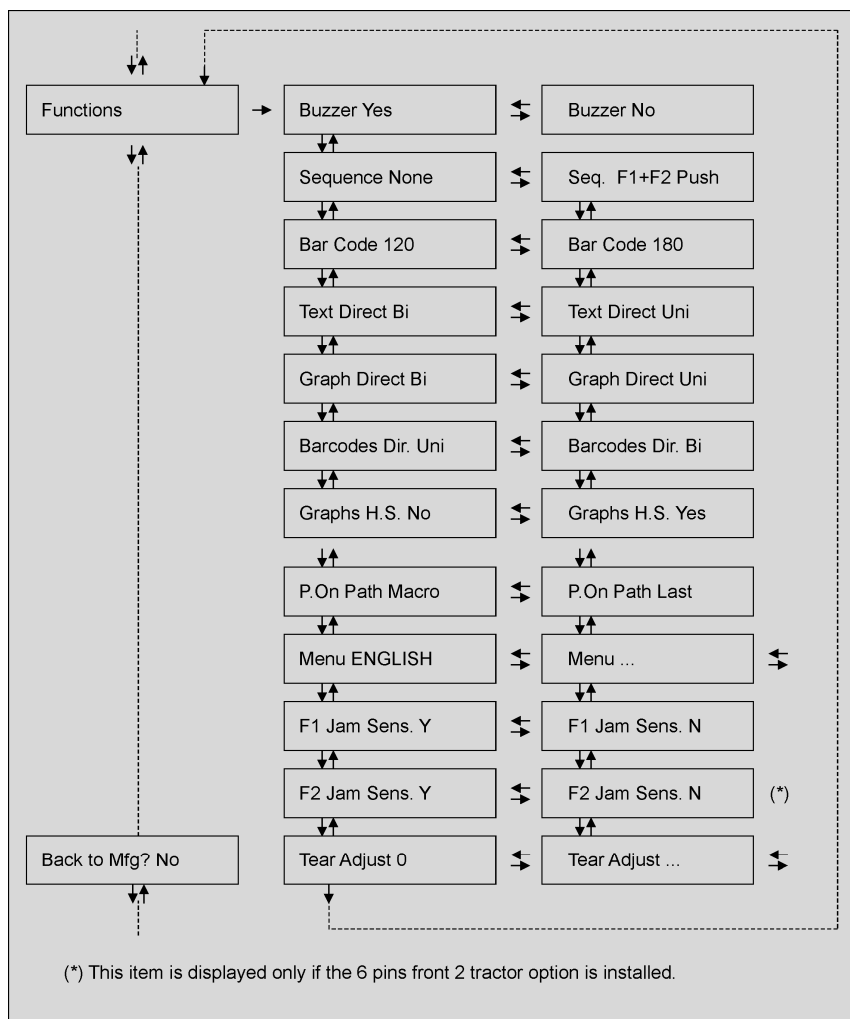

Setting the Functions Group Items

Enable/Disable the Buzzer

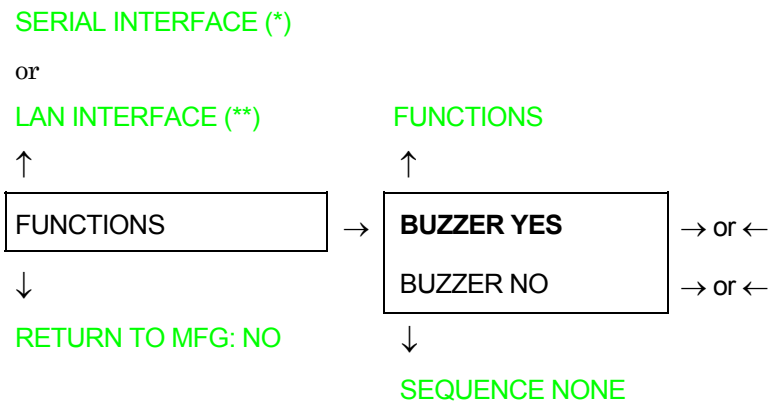

Enable or disables the buzzer.

(*) If Serial Interface is present.

(**) If LAN Interface is present.

Paper Loading Sequence

BUZZER YES

↑

SEQUENCE NONE	→ or ←
SEQ. F1+F2 PUSH	→ or ←

↓

BAR CODE 120 DPI

These items are displayed only if the accessories to which they refer are installed.

SEQUENCE NONE The paper is fed only through the path selected by operator panel.

SEQ. F1+F2 PUSH The paper is fed firstly with the Front1 push tractor and successively through the Front2 push tractor option.

Bar Code Density

SEQUENCE NONE

↑

BAR CODE 120DPI	→ or ←
BAR CODE 180DPI	→ or ←

↓

TEXT DIRECT BI

Selects the bar code print density: 120 or 180 dpi.

Text Print Direction

BAR CODE 120DPI



TEXT DIRECT BI	→ or ←
TEXT DIRECT UNI	→ or ←



GRAPH DIRECT BI

Selects the print direction for text: bidirectional or unidirectional.

Graphics Print Direction

TEXT DIRECT BI



GRAPH DIRECT BI	→ or ←
GRAPH DIRECT UNI	→ or ←



BARCODES DIR. UNI

Selects the print direction for graphics: bidirectional or unidirectional.

Bar Codes Print Direction

GRAPH DIRECT BI

↑

BARCODES DIR. BI	→ or ←
BARCODES DIR. UNI	→ or ←

↓

GRAPH H.S. YES

Selects the print direction for bar codes: bidirectional or unidirectional.

Graphics Printing Speed Selection

BARCODES DIR. UNI

↑

GRAPH H.S. NO	→ or ←
GRAPH H.S. YES	→ or ←

↓

P. ON PATH MACRO

GRAPH H.S. NO Selects graphics printing (bit image data) at normal speed.

GRAPH H.S. YES Selects graphics printing (bit image data) at high speed.

Paper Path at Power-On

GRAPH H.S. YES

↑

P. ON PATH MACRO	→ or ←
P. ON PATH LAST	→ or ←

↓

MENU ENGLISH

P. ON PATH MACRO The paper path at power-on is the one from the default Macro.

P. ON PATH LAST The paper path at power-on is the last one that was selected before the printer was powered off.

Selection of the Language of the Display Messages

P. ON PATH MACRO

↑

MENU ENGLISH	→ or ←
MENU ITALIANO	→ or ←
MENU FRANCAIS	→ or ←
MENU ESPANOL	→ or ←
MENUE DEUTSCH	→ or ←

↓

F1 JAM SENS. Y

These items are self explaining.

See also “[Selecting the Display Language](#)” before in this manual.

Enable/Disable Lower Tractor Jam Sensor

MENU ENGLISH

↑

F1 JAM SENS. Y	→ or ←
F1 JAM SENS. N	→ or ←

↓

F2 JAM SENS. Y

or

TEAR ADJUST:xxx

F1 JAM SENS. Y Enables the paper jam sensor located in the 6 pin Front1 push tractor option.

F1 JAM SENS. N Disables the paper jam sensor located in the 6 pin Front1 push tractor option.

Enable/Disable Upper Tractor Jam Sensor

This item is displayed only if the Front2 push tractor option is installed.
--

F1 JAM SENS. Y

↑

F2 JAM SENS. Y	→ or ←
F2 JAM SENS. N	→ or ←

↓

TEAR ADJUST: xxx

F2 JAM SENS. Y Enables the paper jam sensor located in the 6 pin Front2 push tractor option.

F2 JAM SENS. N Disables the paper jam sensor located in the 6 pin Front2 push tractor option.

Adjusting the Tear-Off Position

F2 JAM SENS. Y

or

F1 JAM SENS. Y

or

MENU ENGLISH

↑

TEAR ADJUST: +30	→ or ←
TEAR ADJUST: ...	→ or ←
TEAR ADJUST: -390	→ or ←

↓

FUNCTIONS

TEAR ADJUST: xxx

These values adjust the distance between the Tear-Off Perforation and the Tear-Off Bar. The values correspond to 1/180 inch units, i.e. the tuning ranges between +1/6 and -13/6 inch. **0** is the default value.

See also “[How to Use the Tear-Off Function](#)”, later in this Chapter.

Resetting to Factory Default Values

With the **BACK TO MFG** function it is possible to reset all items in the *Power On Configuration Setup* and in the *Program Setup* to their factory default values. This may be useful if you do not remember the values you set in the setups, or because you simply changed your mind about the settings you have just done. The default values for the setup items are indicated in bold.

FUNCTIONS

↑

BACK TO MFG: NO

→ or ←

BACK TO MFG: YES

↓ or PROG

PRINT OUT ?

If you want to select **BACK TO MFG: YES**, you have to exit from this item using the ↑ or the ↓ key, in order to confirm the selection of this value.

At this point, the *Power On Configuration Setup* procedure is finished. If you exit pressing the ↓ and the PROGRAM key, the new settings will be saved.

Do not power off the printer before all data have been written into the NVM and the printer has returned online.

Program Setup

The default values of the various functions are indicated in bold.

Entering the Program Setup

Press the PROGRAM key when the printer is turned on and is offline or online without printing. The following message will be displayed:

PRINT OUT? NO

The figure in the following page shows the structure and how to move inside the Program Setup.

Main Structure

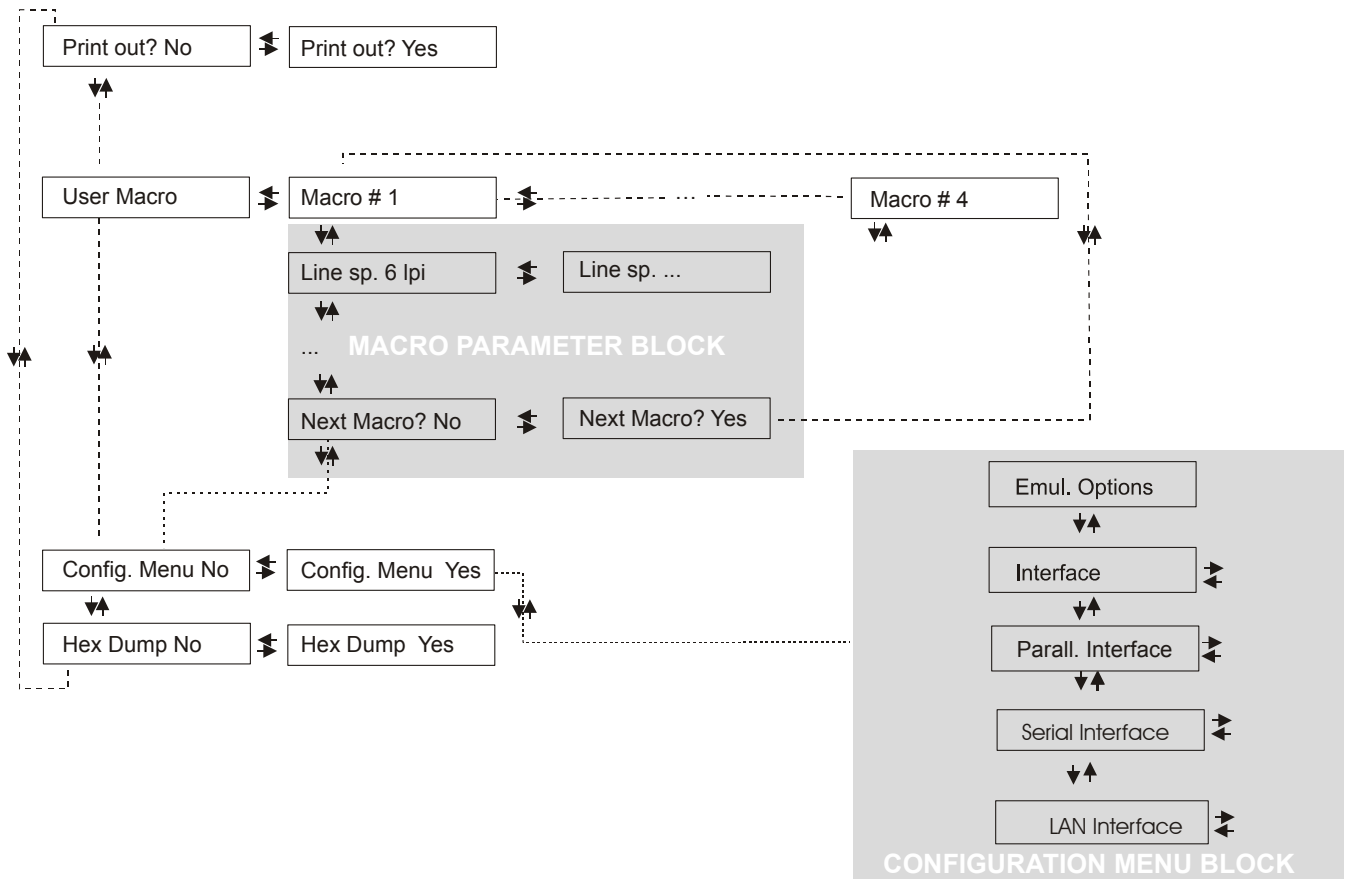

The items define the following parameters:

- Four user macros
- The direct access to the Power-On Configuration
- Hexadecimal printout

Printout of the Printer Settings

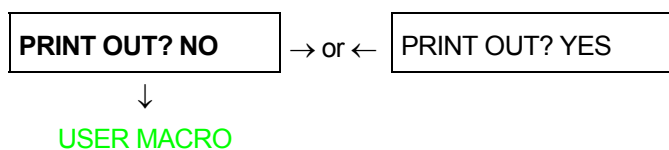

PRINT OUT? NO The setup is not printed.

PRINT OUT? YES The printer setup is printed. The printout starts as soon as you select this value.

NOTE: The Program setup printout indicates:

- the currently selected values,
- the current selected macro is marked with the #x# symbols (USER MACRO #x#),
- the current firmware release.

User Macro

The USER MACRO item allows to prepare four printing environments (MACRO#1, MACRO#2, MACRO#3 and MACRO#4). Each macro is composed of a group of parameters which define a configuration that can then be recalled to easily set the printer for four printing environments.

Selection of the User Macro

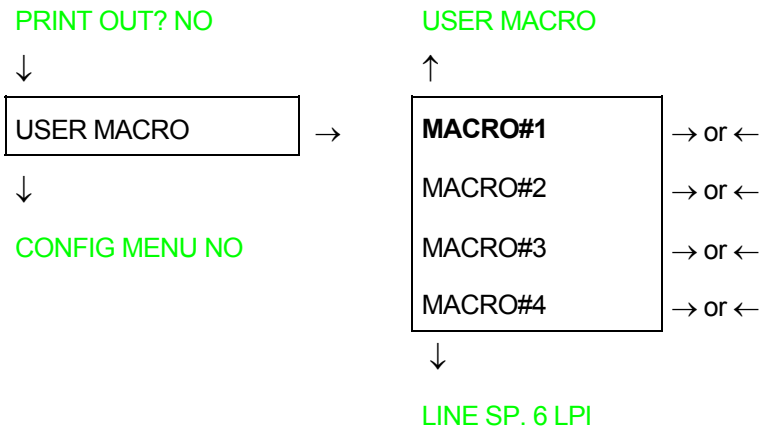

Selection of the macro for which you intend to set the parameters.

When a new macro is selected and the fanfold paper is present in the paper path set in the previous macro, it will be automatically parked (TEAR IF NECESS/PARK PAPER is displayed). Tear off this fanfold paper and press PARK key.

User Macro Parameters

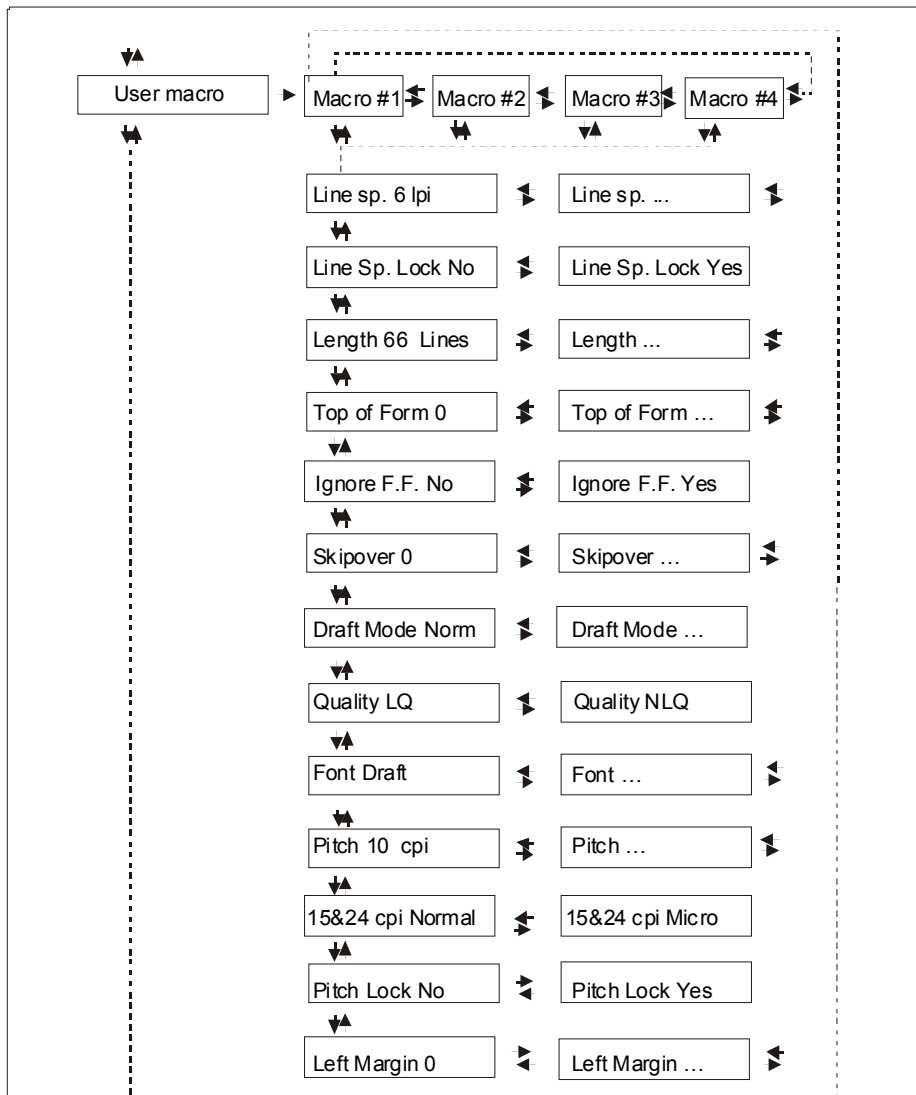

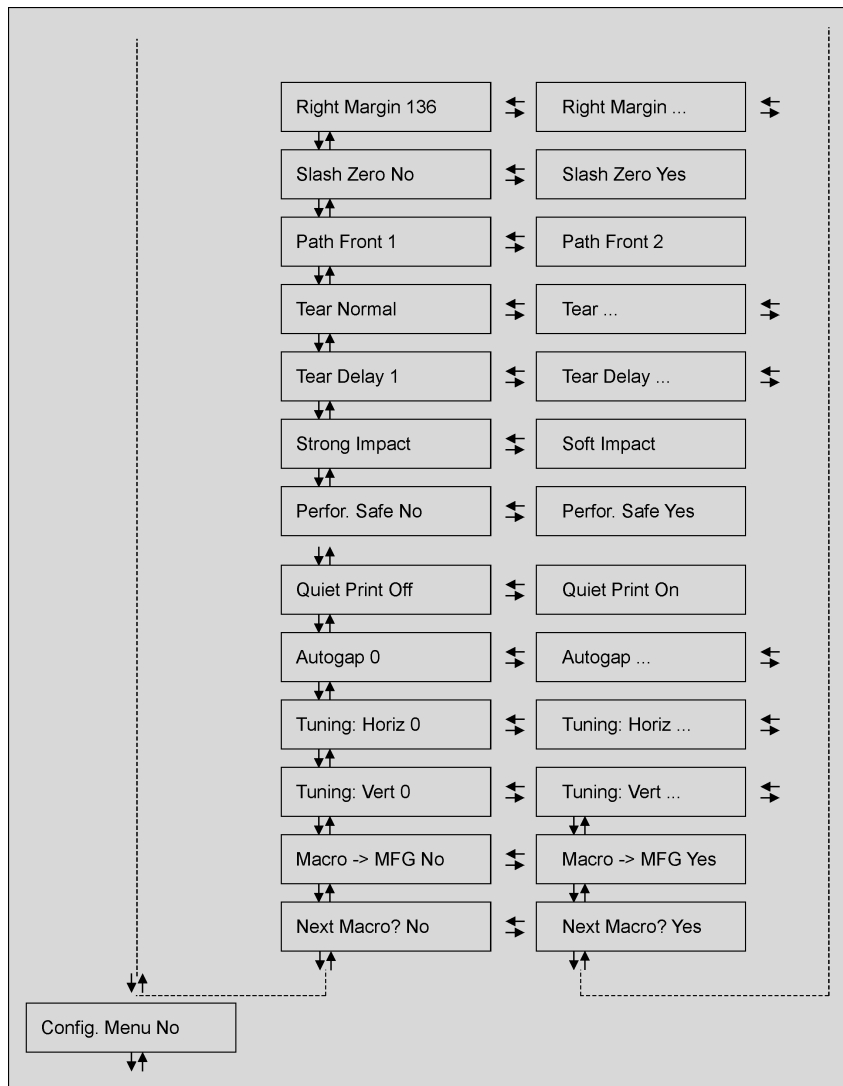

Line Spacing

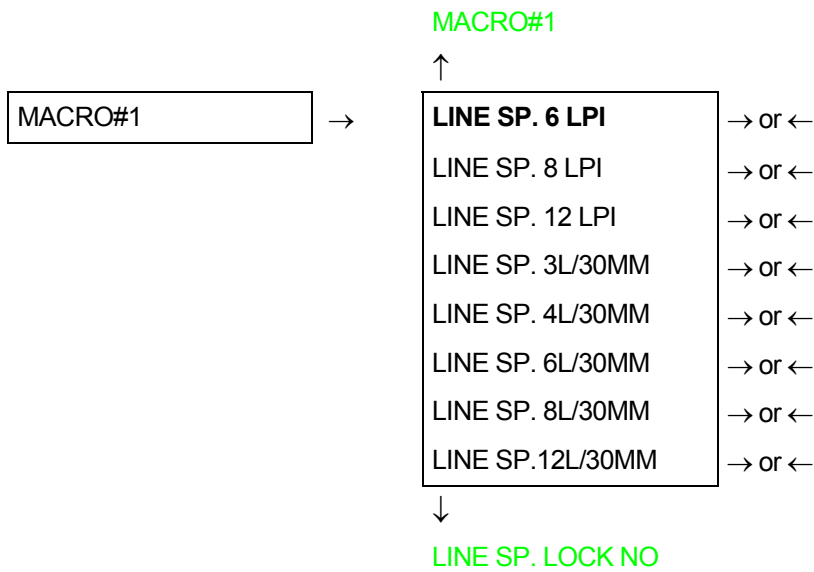

These values define the line spacing in lines/inch (6, 8, 12) or in lines per 30 mm (3, 4, 6, 8, 12).

Line Spacing Lock

LINE SP. 6 LPI

↑

LINE SP. LOCK NO	→ or ←
LINE SP. LOCK YES	→ or ←

↓

LENGTH xxx

LINE SP. LOCK NO Setting this item, the value set for vertical spacing can be changed by software or operator panel.

LINE SP. LOCK YES Setting this item, the value set for vertical spacing cannot be changed by software but only by operator panel.

Page Length

LINE SP. LOCK NO

↑

LENGTH 1 LINE	→ or ←
LENGTH ... LINES	→ or ←
LENGTH 244 LINES	→ or ←

↓

TOP OF FORM 0

These items set the page length for fanfold paper in number of lines depending on the current vertical spacing. Default value is **66 lines**.

Top of Form

LENGTH xx

↑

TOP OF FORM 0	→ or ←
TOP OF FORM ...	→ or ←
TOP OF FORM xxx	→ or ←

↓

IGNORE F.F. NO

These items set the top of form. The values range between 0 and the page length - 1.

Form Feed (FF) Command

TOP OF FORM 0

↑

IGNORE F.F. NO	→ or ←
IGNORE F.F. YES	→ or ←

↓

SKIPOVER 0

IGNORE F.F. NO The Form Feed (FF) command is always executed.

IGNORE F.F. YES The Form Feed (FF) command is ignored when the paper is in the top of form (TOF) position. A Form Feed can be performed if the LOAD/FF key is pressed.

Skip Over Perforation

IGNORE F.F. NO

↑

SKIPOVER 0	→ or ←
SKIPOVER ...	→ or ←
SKIPOVER xxx	→ or ←

↓

DRAFT MODE NORM

These items set the skipover perforation. The values range between 0 and the page length - 1.

Draft Print Mode Selection

SKIPOVER 0

↑

DRAFT MODE NORM	→ or ←
DRAFT MODE BEST	→ or ←
DRAFT MODE HS	→ or ←

↓

QUALITY LQ

DRAFT MODE NORM The printer performs the draft printing at normal speed.

DRAFT MODE BEST The printer performs the draft printing at low speed to obtain better quality printing.

DRAFT MODE HS The printer performs the draft printing at high speed.

Quality Print Mode Selection

DRAFT MODE NORM

↑

QUALITY LQ	→ or ←
QUALITY NLQ	→ or ←

↓

FONT Draft

QUALITY LQ The printer performs the Letter Quality printing.

QUALITY NLQ The printer performs the Near Letter Quality printing.

Font Selection

QUALITY LQ

↑

FONT Draft	→ or ←
FONT Courier	→ or ←
FONT OCR-B	→ or ←
FONT Gothic	→ or ←
FONT Prestige	→ or ←
FONT Present	→ or ←
FONT OCR-A	→ or ←
FONT Script	→ or ←

↓

PITCH 10 CPI

Selects the fonts. OCR-A is displayed only if a non proportional pitch has been selected.

Pitch Selection

FONT Draft

↑

PITCH 5 CPI	→ or ←
PITCH 6 CPI	→ or ←
PITCH 7.5 CPI	→ or ←
PITCH 8.5 CPI	→ or ←
PITCH 10 CPI	→ or ←
PITCH 12 CPI	→ or ←
PITCH 15 CPI	→ or ←
PITCH 17.1 CPI	→ or ←
PITCH 20 CPI	→ or ←
PITCH 24 CPI	→ or ←
PITCH PROP	→ or ←

↓

15&24CPI NORMAL

These items set the horizontal spacing in characters per inch. The PITCH PROP item sets proportional character spacing.

Micro Dot Print Mode

PITCH 10 CPI

↑

15&24CPI NORMAL	→ or ←
15&24CPI MICRO	→ or ←

↓

PITCH LOCK NO

15&24CPI MICRO The print matrix uses 8 x 8 dots only if the horizontal spacing is 15 or 24 cpi (micro mode).

15&24CPI NORMAL The print matrix uses 12 x12 dots (normal mode).

Pitch Lock

15&24CPI NORMAL

↑

PITCH LOCK NO	→ or ←
PITCH LOCK YES	→ or ←

↓

LEFT MARGIN 0

PITCH LOCK NO Setting this item, the pitch can be changed by software or operator panel.

PITCH LOCK YES Setting this item, the pitch can be changed ONLY by operator panel.

Left Margin

PITCH LOCK NO

↑

LEFT MARGIN 0	→ or ←
LEFT MARGIN ...	→ or ←
LEFT MARGIN xxx	→ or ←

↓

RIGHT MARGIN 136

The Left Margin is set in number of columns (depending on the current pitch) starting from the physical left edge.

Right Margin

LEFT MARGIN 0

↑

RIGHT MARGIN. 2	→ or ←
RIGHT MARGIN. ...	→ or ←
RIGHT MARGIN. xxx	→ or ←

↓

SLASH ZERO NO

The Right Margin is set in number of columns (depending on the current pitch) starting from the physical left edge. The default value is **136**.

Zero Character Printing

RIGHT MARGIN 136

↑

SLASH ZERO NO	→ or ←
SLASH ZERO YES	→ or ←

↓

PATH FRONT 1

You can select the Zero character printing with or without a slash.

Paper Path Selection

This function defines the default paper path for the current macro. Paper Path selection depends upon the printer model and the installed options.

SLASH ZERO NO

↑

PATH FRONT 1	→ or ←
PATH FRONT 2	→ or ←

↓

TEAR NORMAL

PATH FRONT 1

Paper loading with the Front1 push tractor (low position).

PATH FRONT 2

Paper loading with the Front2 push tractor (up position). This item is displayed only if the Front2 push tractor option is installed.

Tear-Off Mode

PATH FRONT 1

↑

TEAR NORMAL	→ or ←
TEAR AUTOMATIC	→ or ←
LABEL	→ or ←
TEAR NO	→ or ←

↓

TEAR DELAY 1

TEAR NORMAL	The Tear-Off Function is performed pressing the TEAR key when the printer is offline.
TEAR AUTOMATIC	When the printer is not receiving any data, the paper is moved to the Tear-Off position. It is returned to the Tear-Off position as soon as it receives printing data.
LABELS	This item must be set when printing on labels, in order to avoid paper jams. The paper does not execute any backward movement. When pressing the PARK key, the paper is ejected.
TEAR NO	The paper does not execute any backward movement.

See also “[How to Use the Tear-Off Function](#)” and “[How to Handle the Paper Parking](#)” later in this chapter.

Tear Delay Mode

TEAR NORMAL

↑

TEAR DELAY 1	→ or ←
TEAR DELAY ...	→ or ←
TEAR DELAY 5	→ or ←

↓

STRONG IMPACT

This item defines the time that printer uses to move paper to the Tear-Off position in automatic tear mode. The range of the tear delay is between 1 and 5 seconds. The default value is 1 sec.

Print Impact Strength

TEAR DELAY 1



STRONG IMPACT	→ or ←
SOFT IMPACT	→ or ←



PERFOR. SAFE NO

STRONG IMPACT The impact strength of the print head is set for printing on multicopy paper.

SOFT IMPACT The impact strength of the print head is set for printing few copies.
The printing noise is reduced.

Paper Perforation

This function allows to move the print head aside the paper when the fanfold paper perforation passes between the mylar and the print bar, to facilitate paper movement on critical forms.

STRONG IMPACT



PERFOR. SAFE NO	→ or ←
PERFOR. SAFE YES	→ or ←



QUIET PRINT OFF

PERFOR. SAFE NO The function is disabled. The print head remains in its position, when the perforation of the paper passes.

PERFOR. SAFE YES The function is enabled. The print head is moved aside, when the perforation passes.

Quiet Printing

PERFOR. SAFE NO

↑

QUIET PRINT OFF	→ or ←
QUIET PRINT ON	→ or ←

↓

AUTOGAP 0

QUIET PRINT OFF The function is disabled. Printing at normal noise level.

QUIET PRINT ON The function is enabled. Printing at reduced noise level.

Adjusting the Distance of the Print Head

QUIET PRINT OFF

↑

AUTOGAP -5	→ or ←
AUTOGAP ...	→ or ←
AUTOGAP +3	→ or ←
MANUAL GAP	→ or ←
FIXED GAP 0.3	→ or ←
FIXED GAP ...	→ or ←
FIXED GAP 9.3	→ or ←

↓

TUNING: HORIZ 0

- AUTOGAP xxx** Selecting one of these values sensing the paper thickness. Negative values reduce the distance between the print head and the paper. Default value is `AUTOGAP 0`.
- MANUAL GAP** Selecting this item, the print head must be adjusted manually.
- FIXED GAP xxx** Selecting one of these values the printer adjusts the print head gap to a fixed distance.

Horizontal Character Tuning

AUTOGAP 0

↑

TUNING: HORIZ 0	→ or ←
TUNING: HORIZ ...	→ or ←
TUNING: HORIZ 60	→ or ←

↓

TUNING: VERT 0

These values adjust the distance between the left paper margin and the first print character. The values correspond to 1/120 inch units, i.e. the tuning ranges between 0 and 0.5 inch.

Vertical Character Tuning

TUNING: HORIZ 0

↑

TUNING: VERT. -30	→ or ←
TUNING: VERT. ...	→ or ←
TUNING: VERT. 360	→ or ←

↓

MACRO -> MFG NO

These values adjust the distance between the top paper margin and the first printable line. The values correspond to 1/180 inch units, i.e. the tuning ranges between -1/6 and 2 inch. **0** is the default value.

Resetting the Macro Parameters to the Factory Defaults

TUNING: VERT. 0

↑

MACRO -> MFG NO	→ or ←
MACRO -> MFG YES	→ or ←

↓

NEXT MACRO? NO

MACRO -> MFG NO The new values set for the macro parameters will be the used.

MACRO -> MFG YES The values set for the macro parameters will be reset to their factory defaults.

Selecting Another Macro

MACRO -> MFG NO

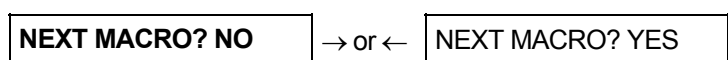

CONFIG MENU NO



MACRO#1

To pass over to another macro, select NEXT MACRO YES. Pressing the ↓ or ↑ key the item MACRO#1 is displayed, then press the → key to pass over to MACRO#2 (MACRO CHANGING is displayed).

When passing over from one macro to another, the fanfold paper loaded from the paper path, selected in the previous macro, will be automatically parked (TEAR IF NECESS/PARK PAPER is displayed). Tear off this fanfold paper and press PARK key.

You can now set the parameters for MACRO#2 as described above. In this way you prepare the second printing environment. Passing over from one macro to the other then sets two different printing environments.

Passing over to the Power-On Configuration

At this point of the setup, it is possible to pass over to the *Power On Configuration* functions setting.

NEXT MACRO NO

↑

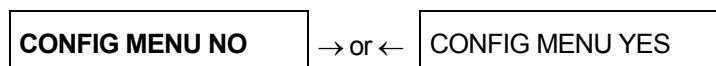

↓

HEX DUMP NO

↓

EMUL. OPTIONS

These items are self-explaining.

Hexadecimal Dump

CONFIG MENU NO

↑

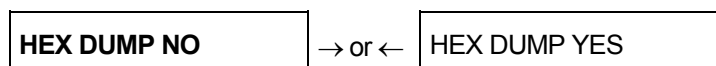

↓

STORE? QUIT

If you select HEX DUMP YES, press the PROGRAM key to set this item. The hexadecimal printing continues, until the HEX DUMP NO item is selected, entering again into the *Program Setup*.

Storing the values

HEX DUMP NO

↑

STORE? QUIT	→ or ←
STORE? SAVE	→ or ←
STORE? CURRENT	→ or ←

PROG

EXIT

- STORE? QUIT** This setting does not save any of the new values set. The values set previously will be used.
- STORE? SAVE** The values set are stored permanently (in the NVM) and will be used until they are changed by the operator.
- STORE? CURRENT** The values set are valid until the printer is turned off. When you turn the printer on again, the values set in the preceding setup will be used.

At this point the Program Configuration Setup is finished. You exit pressing the PROGRAM key.

ANSI Emulation

The following items appear only when the ANSI emulation has been selected.

ANSI Character Sets

EMULATION ANSI



CHAR SET CS1	→ or ←
CHAR SET CS2	→ or ←



CH.TAB CODE 437

CHAR SET CS1 The printer uses the CS1 character set.

CHAR SET CS2 The printer uses the CS2 character set.

ANSI Code Pages

CHAR. SET CS2



CH.TAB CODE437	→ or ←
CH.TAB ...	→ or ←
CH.TAB CODE 850	→ or ←



NATION USA

The following code pages are available:

CODE 437	CODE 850	CODE 851	CODE 852	CODE 853	CODE 855	CODE 858	CODE 860
CODE 863	CODE 864	CODE 865	CODE 866	CODE 867	ISO 1	ISO 2	ISO 3
ISO 4	ISO 5	ISO 6	ISO 7	ISO 8	ISO 9	ISO 15	MAZOWIA
TURKISH	CP 437G	ROMAN-8	KAMENICKY	CWI	IN2	CODE 864E	CP1250
CP 1251	CP 1252	CP 1253	CP 1254	CP 1255	CP 1256	CP 1257	BULGAR

ANSI Code Pages

CH.TAB.. CODE437

↑

NATION USA	→ or ←
NATION ...	→ or ←
NATION CYRILLIC	→ or ←

↓

RIS ENABLE YES

The following code pages are available:

USA	GERMANY	FRANCE A	FRANCE B	FREN/CANA	DUTCH	ITALY	UK
SPAIN	DAN/NOR A	DAN/NOR B	DAN/NOR C	DAN/NOR D	SWE/FIN A	SWE/FIN B	SWE/FIN C
SWE/FIN D	SWISS	YUGOSLAV	UK A	TURKEY	GREEK	CYRILLIC	

Reset Enable

NATION USA

↑

RIS ENABLE YES	→ or ←
RIS ENABLE NO	→ or ←

↓

RIS ENABLE YES

If the printer receives a command (ESC c) from the host to reset the printer, then the printer will (YES) or will not (NO) reset the current configuration to the power-up configuration.

SI/SO Control

RIS ENABLE YES

↑

SI/SO CTL YES	→ or ←
SI/SO CTL NO	→ or ←

↓

AUTO CR YES

If the printer receives a command (SI or SO) from the host to enable or disable the special modes (oversize, expanded and bar code modes), then the printer will (YES) or will not (NO) respond to the <SI> and <SO> commands based upon your selection.

Auto Carriage Return

SI/SO CTL YES

↑

AUTO CR YES	→ or ←
AUTO CR NO	→ or ←

↓

PRIME ON DEL YES

If the printer receives a command (LF) from the host to perform a line feed then the printer will (YES) or will not (NO) append a carriage return based upon your selection.

Prime on Delete

AUTO CR YES

↑

PRIME ON DEL YES	→ or ←
PRIME ON DEL NO	→ or ←

↓

CONTRL IN DG YES

If the printer receives a command (DEL) from the host, then the printer will (YES) or will not (NO) perform a prime (reset) based upon your selection.

Control Codes in Dot Graphics

PRIME ON DEL YES

↑

CONTRL IN DG YES	→ or ←
CONTRL IN DG NO	→ or ←

↓

CONTRL IN DG YES

If the printer receives a control code from the host while in dot graphics mode, then the printer will (YES) or will not (NO) respond to the particular control code based upon your selection.

Vertical Expansion

CONTRL IN DG YES

↑

EXPAND UP YES	→ or ←
EXPAND UP NO	→ or ←

↓

ALT GRAPHICS YES

This setting defines the vertical expansion from the baseline up (YES) or from the top line down (NO).

ALT Graphics

EXPAND UP YES

↑

ALT GRAPHICS YES	→ or ←
ALT GRAPHICS NO	→ or ←

↓

8 BIT CTRL YES

If is selected N: the 6-bit graphics horizontal densities are multiplies of 72.
If is selected Y: the 6-bit graphics horizontal densities are multiplies of 60.

8-bit Control

ALT GRAPHICS YES

↑

8 BIT CTRL YES	→ or ←
8 BIT CTRL NO	→ or ←

↓

S/SUB SCRIPT YES

If the printer receives a control code command (80H to 9FH) whose eighth data bit is set, and the character set is selected, then the printer will (YES) or will not (NO) respond to the particular code based upon your selection.

Superscript/Subscript Character Enable

8 BIT CTRL YES

↑

S/SUB SCRIPT YES	→ or ←
S/SUB SCRIPT NO	→ or ←

↓

ESC+CTR CODE YES

The printer will (YES) or will not (NO) respond to ESC [2 m and ESC [3 m commands.

ESC+Control Code

S/SUB SCRIPT YES

↑

ESC+ CTR CODE YES	→ or ←
ESC+ CTR CODE NO	→ or ←

↓

VT NOT SET YES

In this setting the control codes embedded within escape sequence are valid (YES) or ignored (NO). In both cases, the escape sequence will be valid.

VT Code

ESC+ CTR CODE YES

↑

VT NOT SET YES	→ or ←
VT NOT SET NO	→ or ←

↓

DOUBLE LF YES

In this setting the VT code received without tab set will yield line feed (YES) or will be ignored (NO).

Double Line Feed

VT NOT SET YES

↑

DOUBLE LF YES	→ or ←
DOUBLE LF NO	→ or ←

↓

DOUBLE LF YES

If the printer receives a command (LF) from the host to execute a line feed, then the printer will (Y) or will not (N) also perform double line feed based upon your selection.

Automatic Wrap

DOUBLE LF YES

↑

AUTO WRAP YES	→ or ←
AUTO WRAP NO	→ or ←

↓

CLEAR MARGIN YES

If the printer receives printable data from the host, and such data exceeds the current line length (right margin), then the printer will (Y) or will not (N) continue to print the remaining data on the following line based upon your selection.

If you disable auto wrap by selecting N, then the data beyond the right margin is discarded up to the next line terminator.

Clear Margin

AUTO WRAP YES

↑

CLEAR MARGIN YES

→ or ←

CLEAR MARGIN NO

→ or ←

↓

BACKOP NINE

Clears (Y) or preserves (N) top and bottom margins on form length changes.

Backup Option

CLEAR MARGIN YES

↑

BACKUP NONE	→ or ←
BACKUP BC	→ or ←
BACKUP OS	→ or ←
BACKUP BOTH	→ or ←

↓

GUARD BAR YES

BC	The printer will return the print head to the vertical position established before turning on Barcode modes at the completion of printing of the current barcode symbol.
OS	The printer will return the print head to the vertical position established before turning on Oversize modes at the completion of printing of the current barcode symbol.
BOTH	The printer will return the print head to the vertical position established before turning on both Barcode and Oversize modes at the completion of printing of the current barcode symbol.
NONE	The print head will remain in the vertical and horizontal position active at the completion of printing of the selected symbol.

Barcode Guard Bar Enable

BACKUP NONE

↑

GUARD BAR YES	→ or ←
GUARD BAR NO	→ or ←

↓

EMUL. OPTIONS

The printer will (Y) or will not (N) include left, right and center Guard bars of the barcode styles which use Guard bars based upon your selection. The Guard bars extend into the human readable line of the barcode symbol when it is enabled.

How to Select the Paper Path

The paper can be loaded into the printer using different paper paths. The messages indicating the paper paths are shown depending upon the printer model and if the corresponding loading device is installed on the printer.

Proceed as follows:

1. Press the ON LINE key to put the printer offline (ON LINE indicator unlit).
2. Press the PATH key, according to the installed devices the following messages are displayed:

LOAD FRONT 1 For the paper path using the Front1 push tractor.

LOAD FRONT 2 For the paper path using the Front2 push tractor option.

- To load fanfold paper go to “[Loading Paper Using the Front1 Tractor](#)”, “[Loading Paper Using the Front2 Tractor](#)”. When a new paper path is selected, the paper loaded in the printer is automatically parked.

How to Use the Tear-Off Function

This function is used to match the paper perforation with the tear-off bar. For this function the following values must be set:

Selection of the Paper Size

1. Press the PROGRAM key when the printer is disabled or enabled without printing to enter the *Program Setup*.
2. Press the ↓ key and the following message appears:

USER MACRO

3. Press the → key to select the macro for which you want to set the paper size (MACRO#1, MACRO#2, MACRO#3 or MACRO#4).
4. Once the desired macro is displayed press the ↓ key until the following parameter is displayed:

LENGTH xx

5. Press the → or ← key until the desired page size is displayed.
6. Press again the PROGRAM key to exit the setup and set the new value.

Adjusting the Tear-Off Position

To check the Tear-Off Position proceed as follows:

1. Check if the paper perforation matches the tear-off bar on the printer.
2. To move manually the paper to the Tear-Off position, press the TEAR key when the printer is enabled without printing (TEAR NORMAL function selected YES in the *Program Setup*).

You can leave the manual tear off function by pressing again the TEAR key.

If it does not:

1. Turn the printer off and press the PROGRAM key and hold it pressed while powering on the printer until the RELEASE KEYS message is displayed to enter the *Power-On Configuration*.
2. Press the ↓ key until the following message appears:

FUNCTIONS

3. Press the → key to enter and then press the ↓ until the following message is displayed:

TEAR ADJUST xxx

4. Press the → or ← key to scroll the values of this function.

The values below 0 move the tear-off position downwards, values above 0 move the paper upwards. The values can be set between +30 and -390 at 1/180 inches (from +1/6 to -13/6 inches).

5. When the desired value is displayed, press the PROGRAM key.
6. Press the PROGRAM key to save and exit from the setup.

Selection of the Tear-Off Mode

It is now possible to select the Tear-Off Mode.

1. Press the PROGRAM key when the printer is disabled or enabled without printing to enter the *Program Setup*.
2. Press the ↓ key. The following message is displayed:

USER MACRO

3. Press the → key to select the macro for which you want to set the tear-off mode (MACRO#1, MACRO#2, MACRO#3 or MACRO#4).
4. Press the ↓ key, until the following message is displayed:

TEAR NORMAL

Pressing the → or ← key it is now possible to decide how to execute the tear off function:

TEAR NORMAL	Pressing the TEAR key the paper is moved to the tear-off position. Pressing again the TEAR key to exit from the tear-off mode, the paper is moved to the printing position.
TEAR AUTOMATIC	If the printer is not receiving data, the paper is moved automatically to the tear position.
LABEL	The TEAR key is disabled for the tear-off function. This selection is useful when printing on labels. Pressing the PARK key, the printer ejects the paper toward the back of the printer.
TEAR NO	The tear-off function is disabled.

5. Press the PROGRAM key to exit the setup.

How to Lock/Unlock the Printer Setups

To prevent not expertise persons changing the printer setup parameters, it is possible to lock/unlock the access to the printer setups as follows:

- Press ON LINE, MACRO and TEAR keys at the same time and keep them pressed while powering the printer on until the display shows RELEASE KEYS message. As soon as these keys are released, the following messages will be displayed:

then,

STARTING UP

then,

10300 ver. x.xxx

then,

LOCKED MENU

Now the access to the printer setups is locked. If the PROGRAM key is pressed, the LOCKED MENU message is displayed (the PROGRAM key is disabled).

- If you decide to unlock the printer setup, turn the printer off, then press the ON LINE, MACRO and TEAR keys at the same time and keep them pressed while powering the printer on again until the display shows RELEASE KEYS message. As soon as these keys are released, the following messages will be displayed:

then,

STARTING UP

then,

10300 ver. x.xxx

then,

UNLOCKED MENU

How to Handle the Paper Parking

According to the setting of the **TEAR** item in the *Program Setup*, the paper parking procedure is performed in different ways. See the following description:

If **TEAR NO** is selected:

- When the paper is positioned at the first printable line and the paper path is changed (changing the Macro or pressing the **PATH** key) or the **PARK** key is pressed, the printer performs automatically the parking procedure.
- If at least one line has been printed, or the paper has been fed forward at least 1 line and the paper path is changed (changing the Macro or pressing the **PATH** key) or the **PARK** key is pressed, the display shows **TEAR IF NECESS. /PARK PAPER**.
If the paper to be parked is longer than 18" tear it off and press the **PARK** key again to perform the parking procedure.

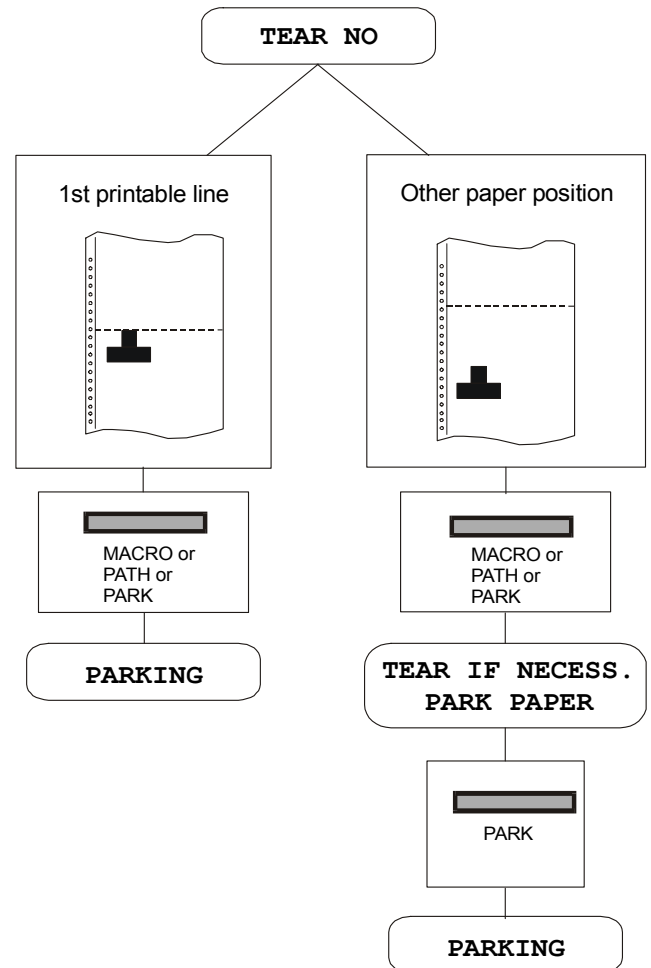

If **TEAR NORMAL** is selected:

- When the paper is positioned at the first printable line and the paper path is changed (changing the Macro or pressing the **PATH** key) or the **PARK** key is pressed, the printer performs automatically the parking procedure.
- If at least one line has been printed, or the paper has been fed forward at least 1 line and the paper path is changed (changing the Macro or pressing the **PATH** key) or the **PARK** key is pressed, the paper is moved to the tear-off position and the display shows **TEAR IF NECESS. /PARK PAPER**. If the paper to be parked is longer than 18" tear it off and press the **PARK** key again to perform the parking procedure.
- When the paper is positioned in the tear-off position after pressing the **TEAR** key, if you press the **PARK** key the printer performs automatically the parking procedure.

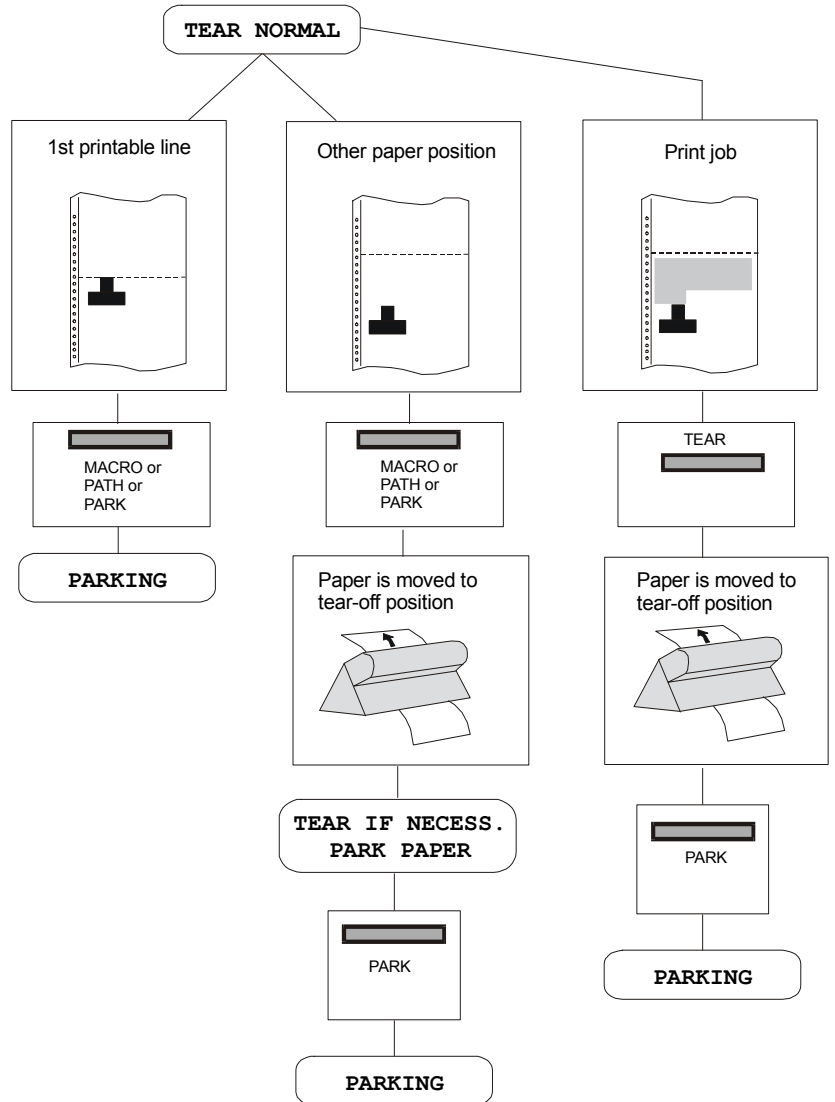

If **TEAR AUTOMATIC** is selected:

- When the paper is positioned at the first printable line and the paper path is changed (changing the Macro or pressing the **PATH** key) or the **PARK** key is pressed, the printer performs automatically the parking procedure.
- If at least one line has been printed, or the paper has been fed forward at least 1 line and the paper path is changed (changing the Macro or pressing the **PATH** key) or the **PARK** key is pressed, the paper is moved to the tear position, the display shows **TEAR IF NECESS. / PARK PAPER**. If the paper to be parked is longer than 18" tear it off and press the **PARK** key again to perform the parking procedure.
- If at least one line has been printed, or the paper has been fed forward at least 1 line and the paper path is changed (changing the Macro or pressing the **PATH** key) or the **PARK** key is pressed when the paper is already in the tear position, the printer performs automatically the parking procedure.

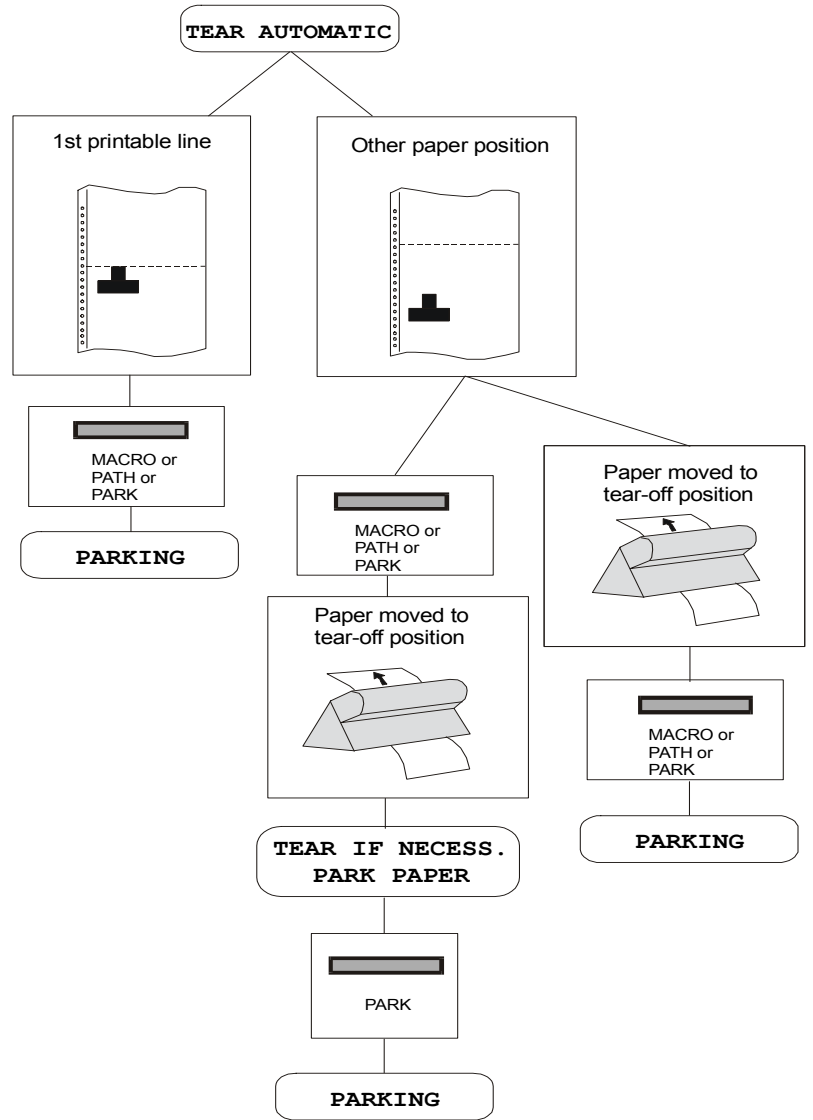

If LABEL is selected:

- When the paper is positioned at the first printable line and the paper path is changed (changing the Macro or pressing the PATH key), or the PARK key is pressed the printer automatically ejects the paper towards the rear of the printer.
- If at least one line has been printed, or the paper has been fed forward at least 1 line and the paper path is changed (changing the Macro or pressing the PATH key) or the PARK key is pressed, the display shows TEAR IF NECESS. /EJECT PAPER. If the paper to be ejected is longer than 18" tear it off and press the PARK key again to perform the paper ejection.

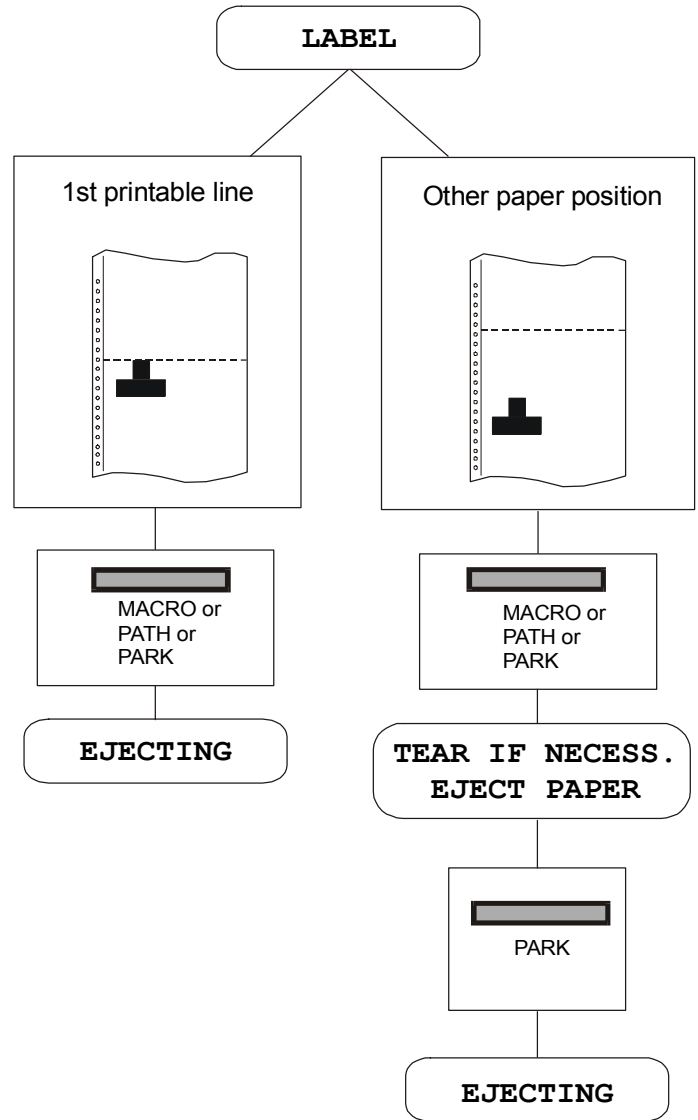

If at power on the paper is already loaded in a paper path that is different to the paper path used by the macro which is valid at power-on, independently from the setting of the TEAR function, the display shows TEAR IF NECESS./EJECT PAPER. If the paper to be ejected is longer than 18" tear it off and press the PARK key again to perform the paper ejection.

In all the above cases the parking procedure may be interrupted pressing the ALTERNATE key. The display shows OPER. INTERRUPTED.

If in any of the above cases you do not tear off the paper and the printer is not able to park it, because it is too long, the display shows TEAR OFF PAPER/PARK PAPER. Tear off the paper and press again the PARK key.

During the parking procedure the display shows PARKING. If the printer is ejecting the paper (see LABEL selection) the display shows EJECTING.

Paper Handling

Paper Specifications

It is important to use the correct paper for obtaining the best performance. See the information table below:

Fanfold Paper

Loading Mode	Front1 Tractor	Front2 Tractor option
Width	76 to 432 mm 3 to 17 inches	76 to 432 mm 3 to 17 inches
Length	76 to 609 mm 3 to 24 inches	76 to 609 mm 3 to 24 inches
Thickness	max. 0.635 mm 0.025 inches	max. 0.635 mm 0.025 inches
Copies	1 + 7	1 + 7
Weight (g/m ²):		
- Original	55 to 150	55 to 150
- Other sheets	45 to 75	45 to 75
- Carbon Paper	35	35

Fanfold Paper Loading

Loading Paper Using the Front1 Push Tractor

1. To select the Front1 push tractor paper path, press the PATH key. The display shows:

LOAD FRONT1

- If you have been using a different path, the display shows:

PATH CHANGING

- If you have been using fanfold paper in the Front2 push tractor paper path (if the Front2 push tractor option is installed), the printer automatically starts the parking procedure. The display shows alternately:

TEAR IF NECESS.

and

PARK PAPER

- Tear off the fanfold loaded with the Front2 push tractor (if it is longer than 18 inches) and press the PARK key. The display shows:

PARKING

followed by

LOAD FRONT1

2. Open the Push tractors cover turning it upwards until it stops.

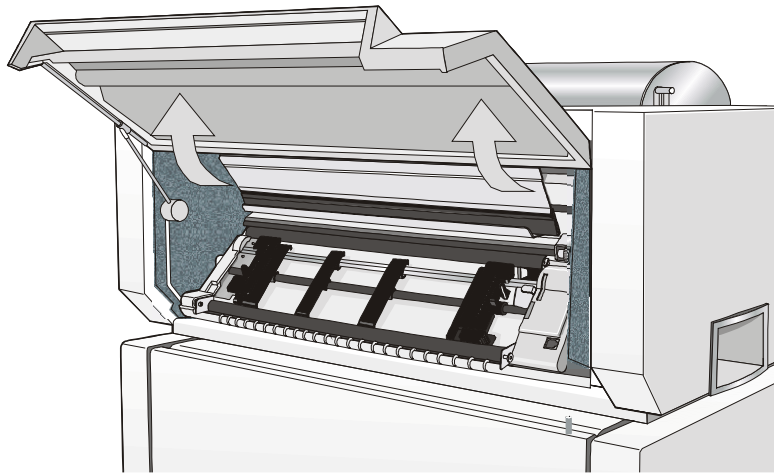

3. If installed, rotate the Front2 tractor outside of the printer.

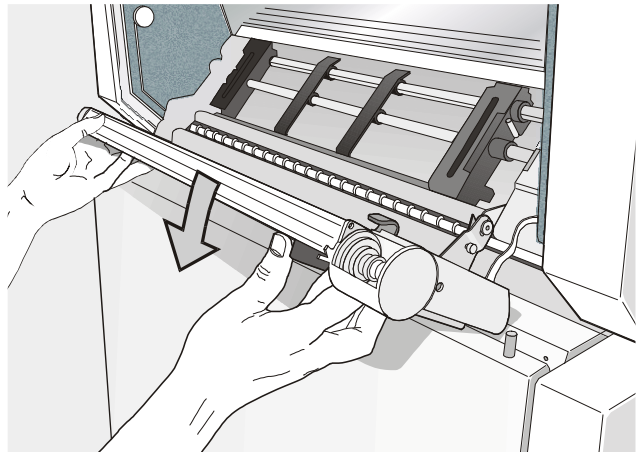

4. Unlock the sprockets of the Front1 tractor moving the sprocket levers up. Slide the left sprocket to the first printing column.

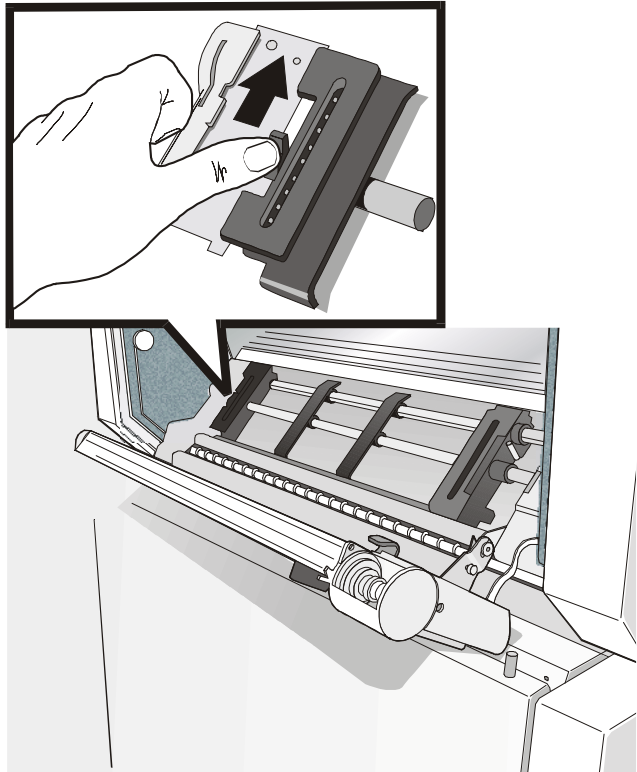

For easier understanding some of the following pictures show the printer without the Front 2 tractor installed.

5. Space the paper guides along the tractor bar. Open the left and right sprocket covers.

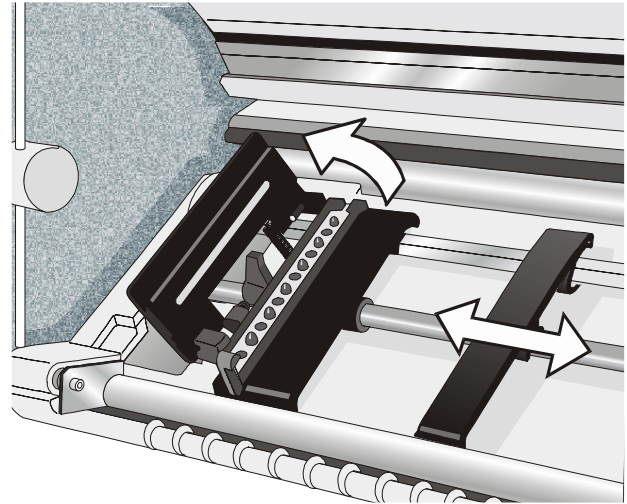

6. If installed, insert the fanfold paper between the lower and the upper tractor.

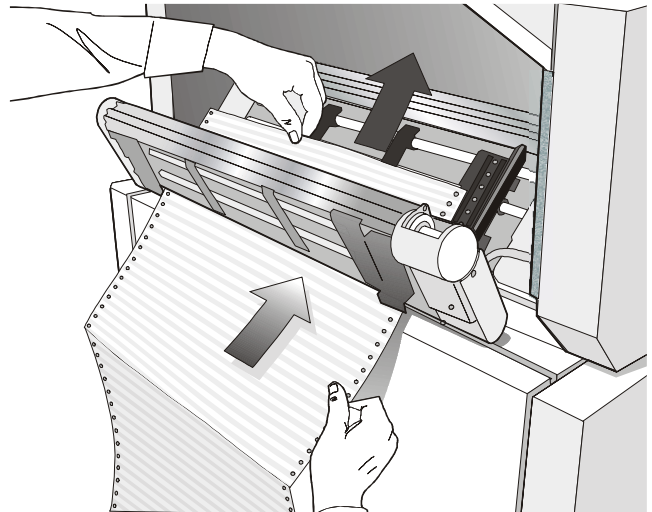

7. Hold the fanfold paper in front of the sprockets and insert the paper perforation on the left sprocket pins and close the sprocket cover.

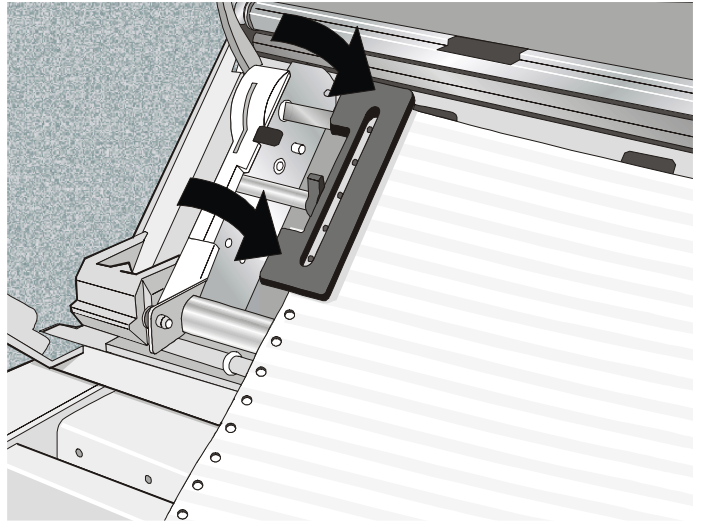

8. Insert the paper on the right sprocket pins, make sure the paper goes under the paper sensor and close the sprocket cover.

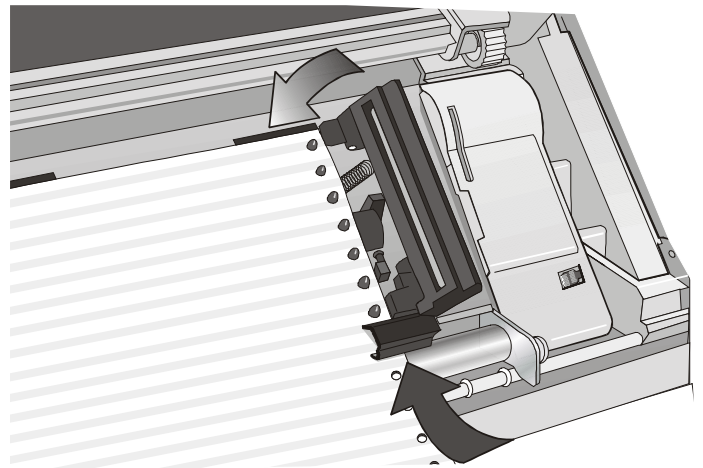

9. Match the left sprocket for the first printing position, i.e. the left paper margin must match the ninth mark on the printer cabinet.

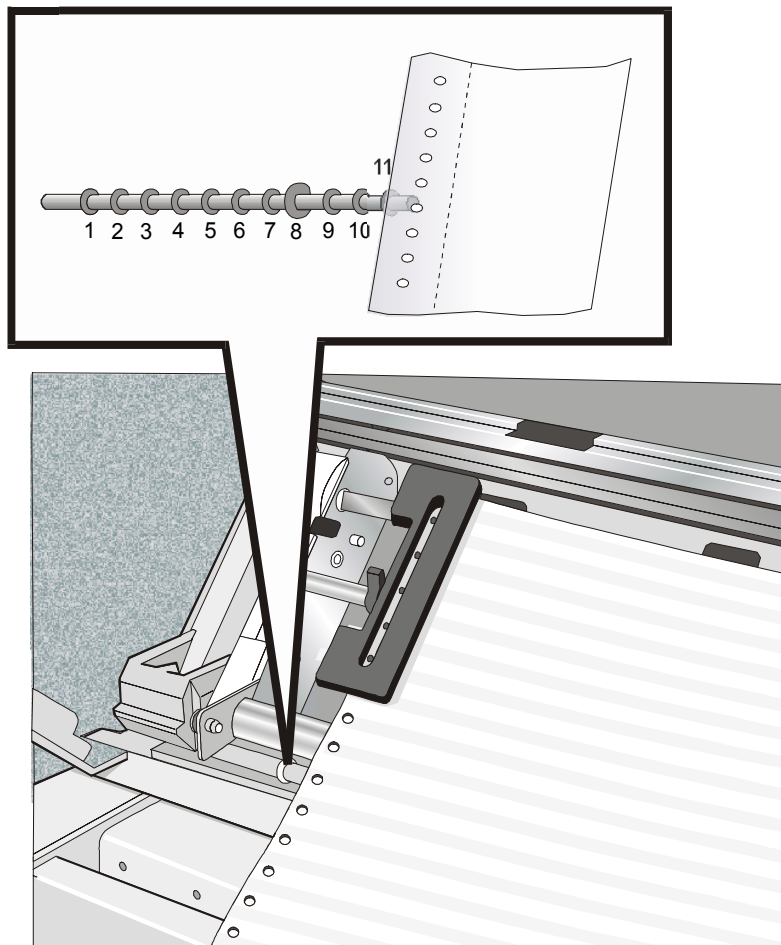

10. Adjust the right sprocket gently to remove slack from the paper.

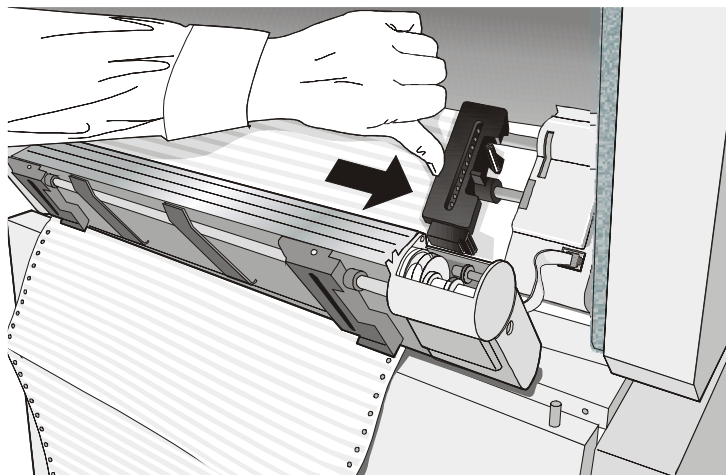

Make sure the paper is not taut.

11. Lock the left and right sprockets moving the sprocket levers up.

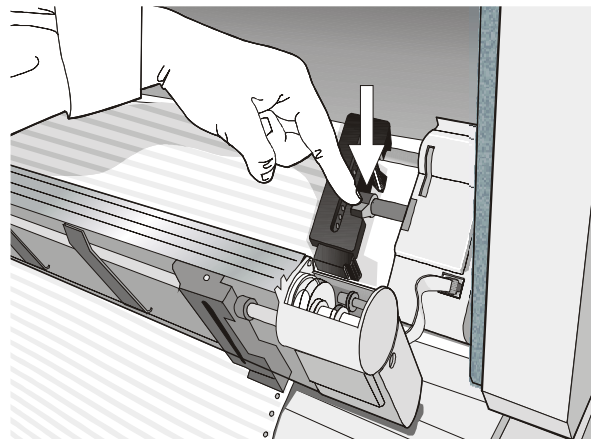

12. If installed, reposition the Front2 tractor in its initial position.

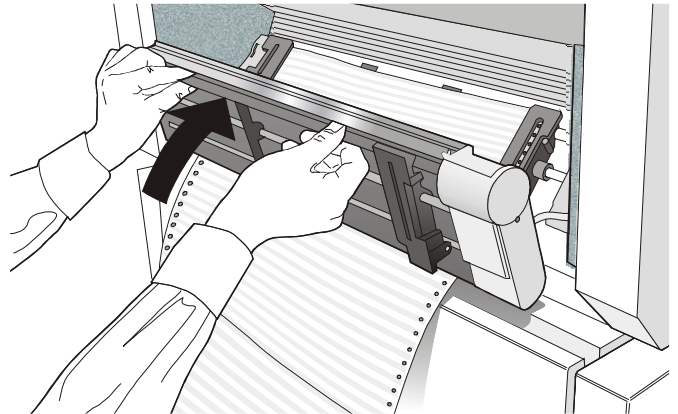

13. If your printer is installed on a table, position the paper staple so that the paper is freely fed into the printer.

If your printer is installed on the optional printer cabinet, open the printer cabinet door and lay the paper staple onto the shelf inside the printer cabinet:

- Onto the lower shelf if you are using only one paper staple. The paper must be fed in front of the antistatic cable;
 - Onto the upper shelf if you are going to install a second paper staple. The paper must be fed behind the antistatic cable.
14. Close the printer cabinet door and the tractor area cover.

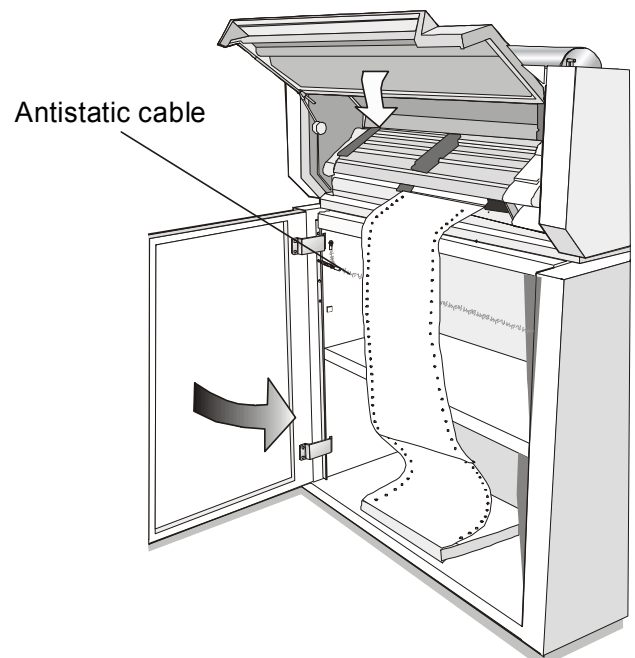

15. a) If only the Front1 push tractor is installed:

- Press the LOAD/FF key to load the paper into the printer.

b) If both the Front1 and the Front2 push tractors are installed:

- press the LOAD/FF key to load the paper into the printer;
- press the ON LINE key, the LOAD FRONT2 message is displayed;
- press the LOAD/FF key to load the paper into the printer;
- press the ON LINE key again, the printer now is ready to print.

The printed paper is output on the rear side of the printer.

- If your printer is located on the optional printer cabinet, the printed paper is collected on the output stacker:

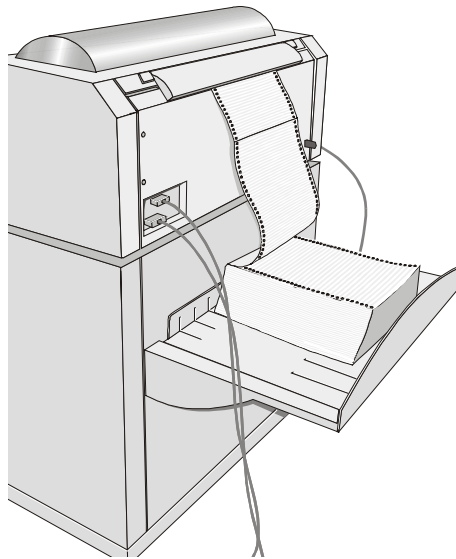

- If the printer is not installed on the cabinet, make sure that there is enough space to stack the printed paper:

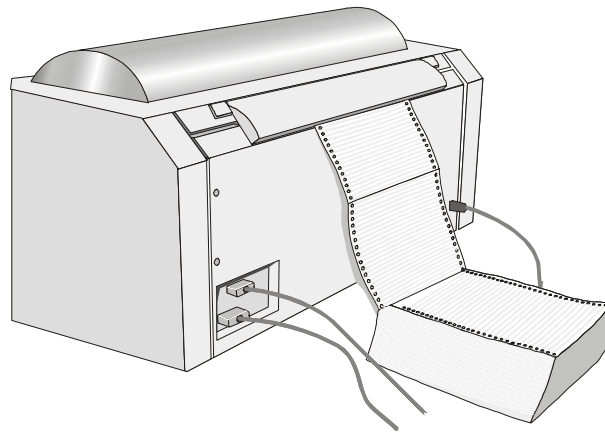

Loading Paper Using the Front2 Tractor

To load paper in this way, it is necessary to install the upper tractor. See before **“Front2 Tractor Installation”** section.

1. To select the Front2 tractor paper path press the PATH key until the display shows:

LOAD FRONT2

- If you have been using a different path, the display shows:

PATH CHANGING

- If you have been using fanfold paper in the Front 1 tractor paper path, the printer automatically starts the parking procedure. The display shows alternately.

TEAR IF NECESS.

and

PARK PAPER

- Tear off the fanfold loaded with the Front 1 tractor (if it is longer than 18 inches) and press the PARK key. The display shows:

PARKING

followed by

LOAD FRONT2

2. Open the tractor area cover turning is upwards until it stops.

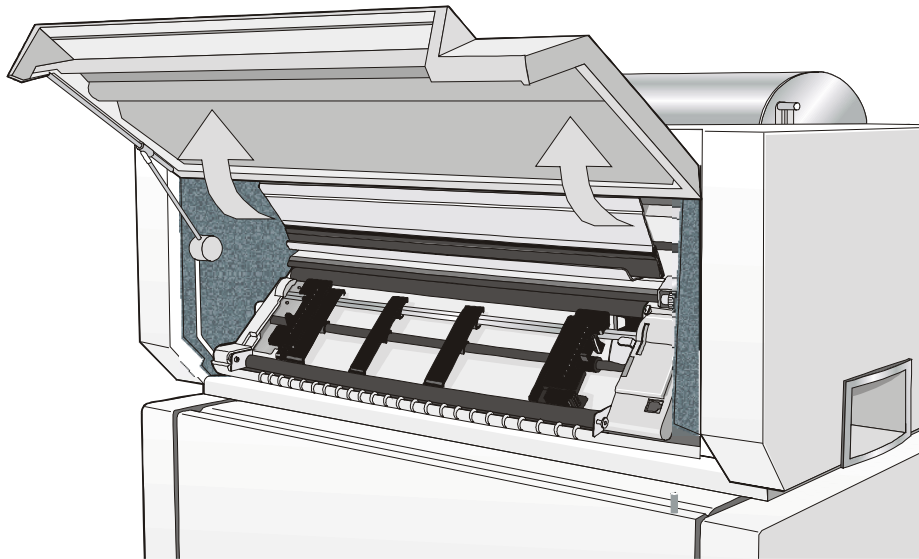

3. Unlock the Front2 tractor sprockets moving the sprocket levers up.

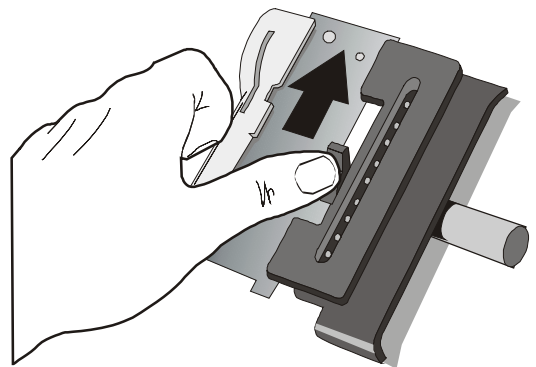

4. Space the paper guides along the tractor bar. Open the sprocket covers of the left and right sprocket.

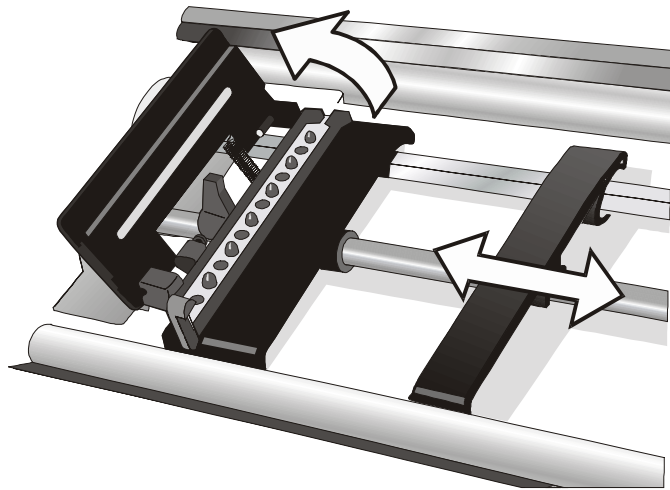

5. Hold the fanfold paper in front of the sprockets and insert the paper perforation on the left sprocket pins and close the sprocket cover.
6. Insert the paper on the right sprocket pins, make sure the paper goes under the paper sensor and close the sprocket cover.

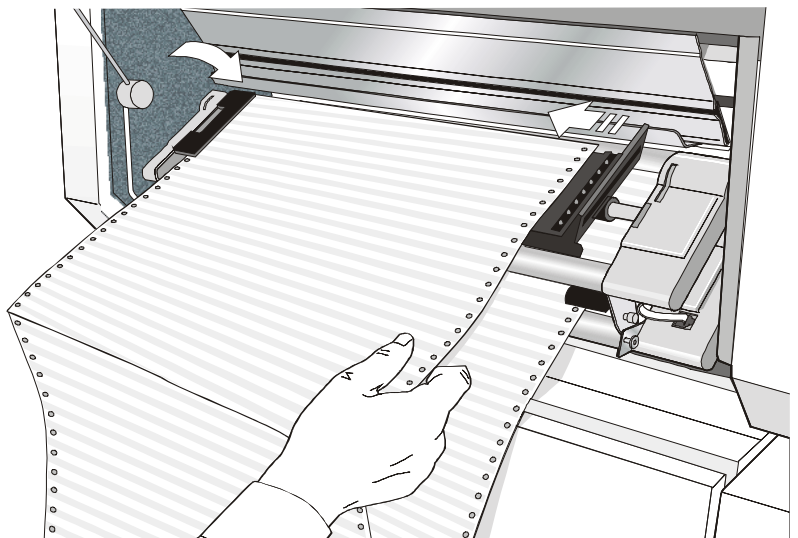

7. Position the left sprocket for printing, matching the left paper margin with the eleventh notch on the printer cabinet and lock it in place.

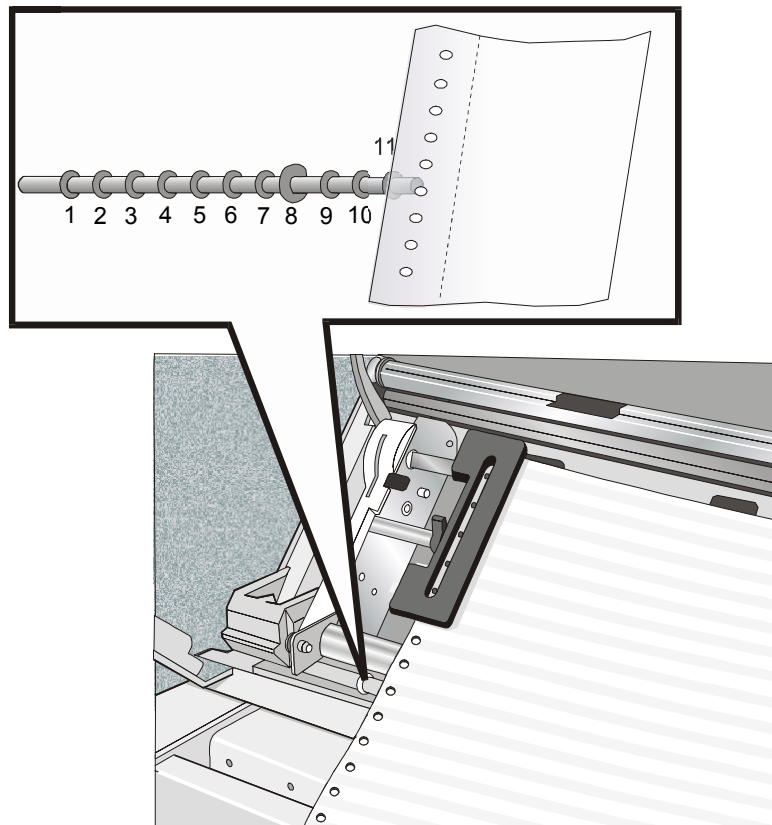

8. Adjust gently the right sprocket to remove slack from the paper.

9. Open the printer cabinet door and lay the paper onto the lower shelf inside the printer cabinet.
 10. Close the printer cabinet door and the tractor area cover.
 11. Press the ON LINE key the following message is displayed: LOAD FRONT2 .
 12. Press the LOAD/FF key to load the paper into the printer.
 13. Press the ON LINE key, now the printer is ready to print.
- The paper is ejected from the rear of the printer.

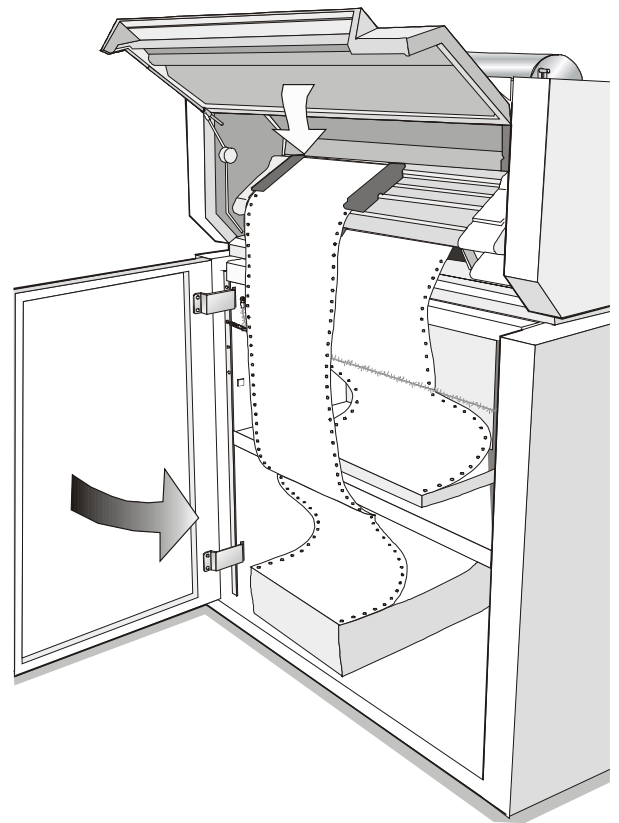

Printer Maintenance and Troubleshooting

Cleaning the Printer

Make sure the printer has been turned off for at least 15 minutes before starting any cleaning operations.

Periodic cleaning will help keep your printer in top condition so that it will always provide optimal performance.

- Use a neutral detergent or water solution on a soft cloth to clean dirt and grease from the cabinet of the printer.
- Do not use an abrasive cloth, alcohol, paint thinner or similar agents because they may cause discoloration and scratching.
- Be especially careful not to damage the electronic and mechanical components.

Replacing the Ribbon Cartridge

1. Make sure that the printer is turned off for at least 15 minutes.

Pay attention to the print head because it becomes hot during operation.

2. Open the top printer cover.
3. Slide the ribbon guide out of the print head.

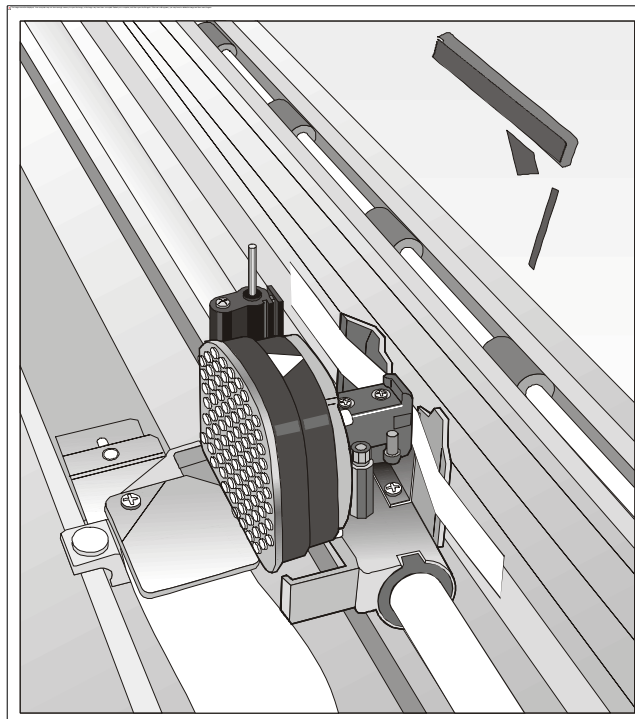

4. Free the shifter holder pushing the tab towards the rear and pulling the shifter holder up.

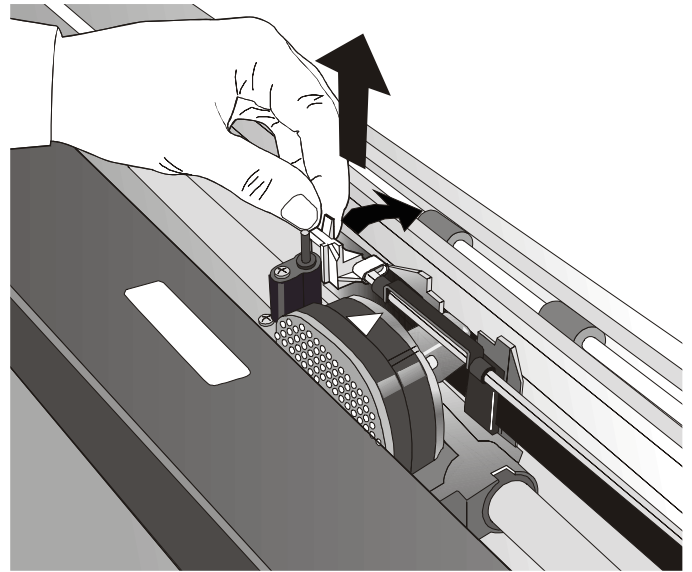

5. Remove the used ribbon cartridge by lifting it up.

Now, you are ready to insert the new ribbon cartridge. See before “[Ribbon Cartridge Installation](#)”.

Printing the Self Test

If you need to know any printer setting, and to check if the printer is working well, print the self-test.

Proceed as follows:

1. Keep the ON LINE key pressed while powering on the printer until the display shows RELEASE KEYS.
2. When you release the key, after initializing the printer starts the self-test printout.
3. To stop the self-test printing, press the ON LINE key again. The printer is offline.

Error Handling

When an error condition occurs:

- the printer is disabled;
- the first message on the display indicates the error, while the second message gives more details concerning the error conditions.

Press always the ON LINE key to reset the error condition.

Error Message Description

Messages	Indication	Solution
A.G.A NOT OPER ADJUST THE GAP	The automatic gap adjustment (A.G.A) is not enabled.	<p>Press the ON LINE key to reset the error condition. Adjust the print head gap to a fixed distance. Select the print head fixed gap adjustment function in the <i>Program Menu</i>.</p> <ul style="list-style-type: none">• Press the PROGRAM key when the printer is disabled (READY indicator unlit) to enter the <i>Program Setup</i>.• Press the ↓ key until the USER MACRO function is displayed. Press the → key until the desired macro is displayed (MACRO#x). <p>Press the → key to enter the macro parameters. Press the ↓ key until the FIXED GAP parameter is displayed. Press the → or ← keys to select the fixed gap adjustment values. From FIXED GAP 1 (simple fanfold paper) to FIXED GAP 4 (multipart fanfold paper).</p>

Messages	Indication	Solution
BUFFER OVERFLOW CHARACTER LOST	A buffer overflow condition occurred (for the serial interface).	Turn the printer off and on again, or press the PROGRAM and ON LINE key successively to clear the buffer.
DATA SET OFF	The DSR Signal is not connected to the printer and is not ready for data transfer (if the serial interface is selected). This condition may happen in a remote connection (via modem) and the DSR (DATA SET READY) signal is missing.	Press the ON LINE key to reset the error condition.
JAM FRONT1 PATH CHECK PAPER	A paper jam error condition occurred in the Front1 paper path.	Check the paper path and remove the jammed paper. Press the ON LINE key to reset the error condition.
JAM FRONT2 PATH CHECK PAPER	A paper jam error condition occurred in the Front2 paper path.	Check the paper path and remove the jammed paper. Press the ON LINE key to reset the error condition.
NO PATH AVAILABLE	An electromechanical failure occurs in the paper paths.	Call Service.
NVM CHANGE REMOVE PAPER	If this error is displayed during the printer power on, an NVM error condition occurs.	Turn the printer off and then on again. If the problem is not solved call Service.

Messages	Indication	Solution
PAPER JAM CHECK ALL PATHS	A paper jam error condition occurs in the paper path.	Check all the paper paths and remove the jammed paper. Press the ON LINE key to reset the error condition.
RIBBON BLOCKED CHECK RIBBON	The ribbon of the cartridge is blocked.	Check that the ribbon is correctly inserted. Turn the tension knob to make sure that the ribbon is not jammed. Press the ON LINE key to reset the error condition.
UNKNOWN TRACTOR	A tractor type that is not recognized has been mounted on the printer.	Check that the installed tractor is compatible with the printer.

Repacking the Printer for Shipment

If you need to ship your printer, it is necessary to repack it to avoid damaging during the transport. Proceed as follows:

When repacking the printer always use the original packing material

1. Find the packing material and the repacking kit.

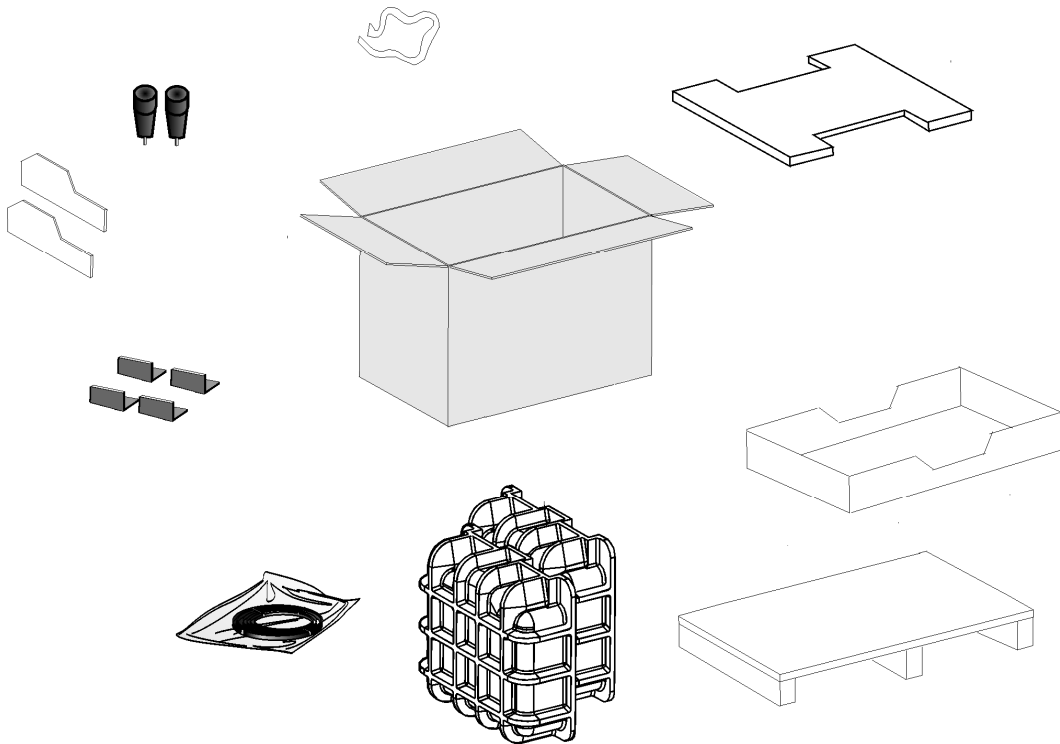

2. Open the upper printer cover and fix the print head and the bail with the fixing strip.

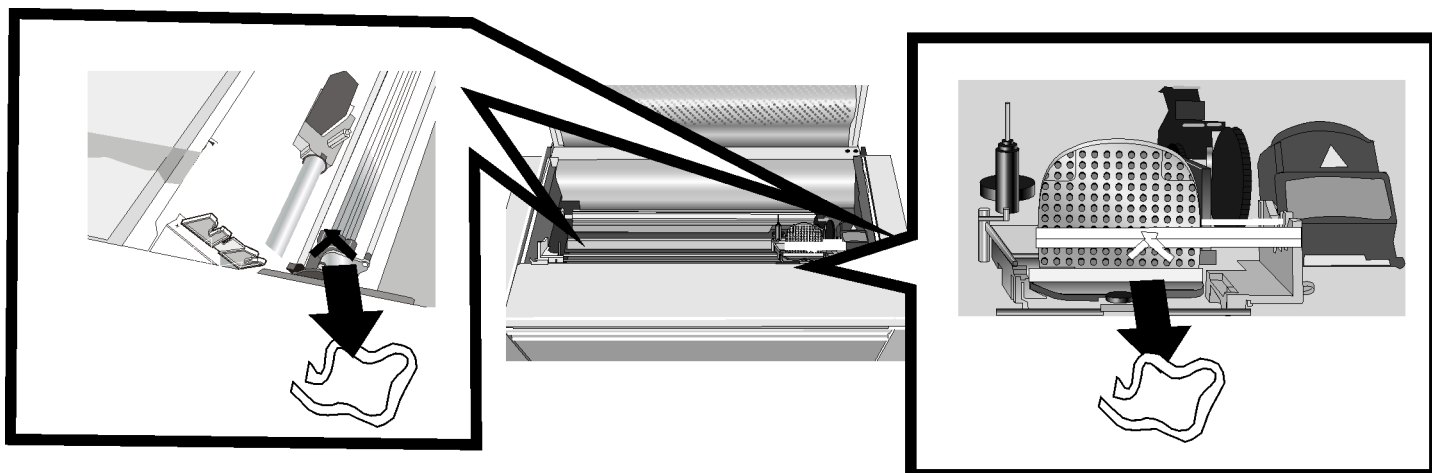

3. Open the tractor area cover, move the paper guides to the center of the tractor and fix the two transport screws.

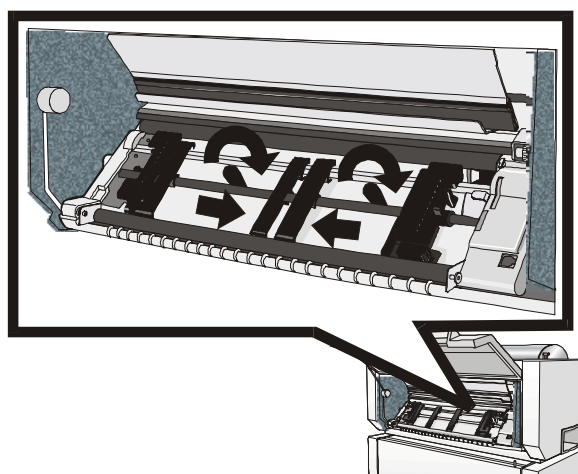

4. With the help of another person move the printer onto the transport foam on the transport pallet. Insert the plastic bag over the printer and the foam shells on both sides of the printer.

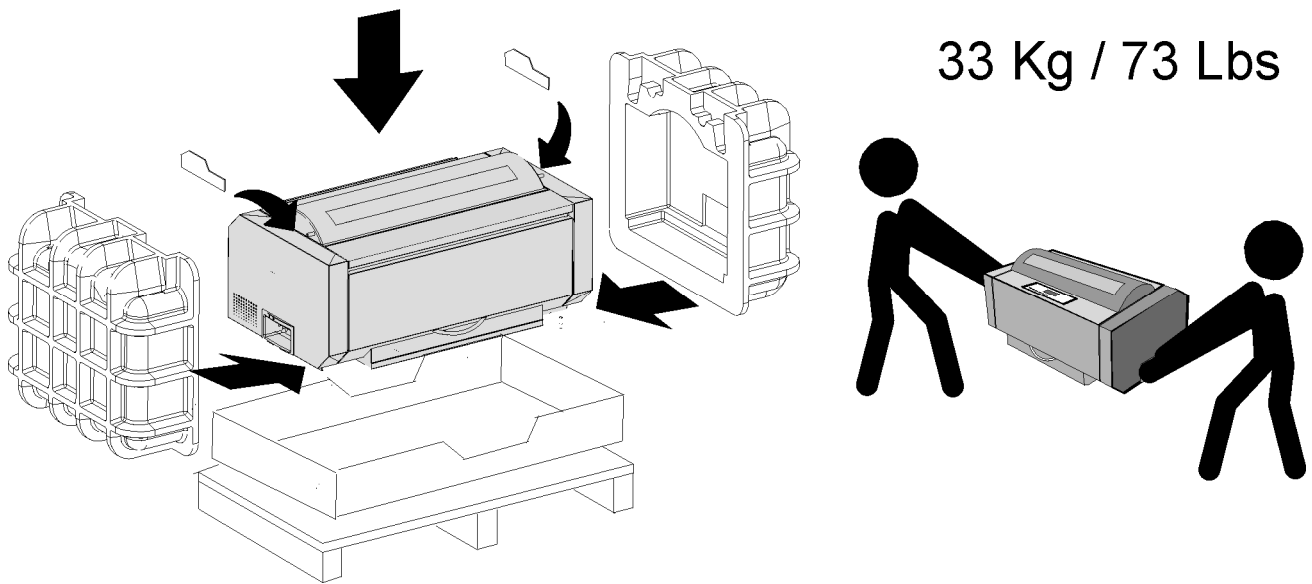

5. Slide the packing box over the printer and insert the accessories onto the printer.
6. Insert the polystyrene panel into the packing box.

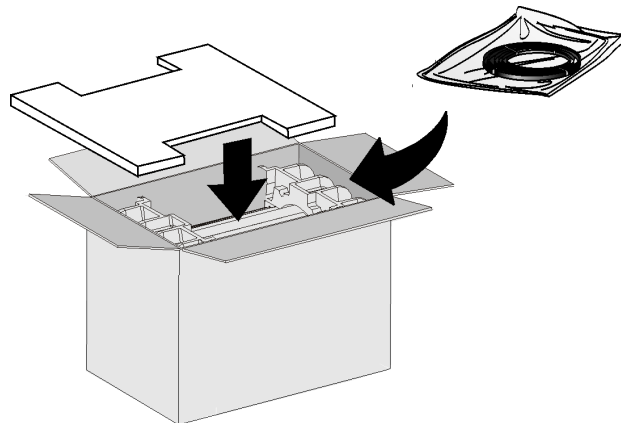

7. Close the packing box and fix it to the transport panel by means of the packing strip, inserting the plastic angles between the packing strip and the carton.

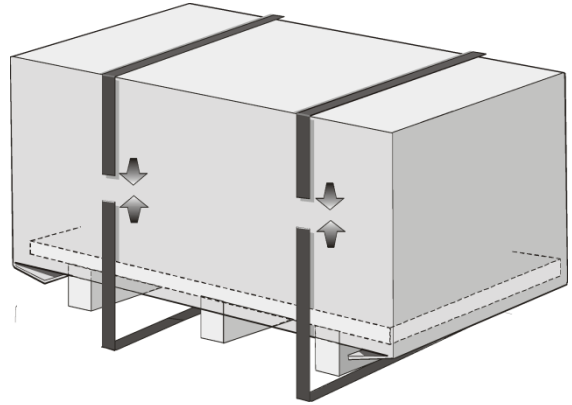

8. Fix the packing strip with the corresponding clips.

Options

The Controller Board

The printer's interface available configurations are:

- Controller board with serial, parallel and USB interfaces
- Controller board with LAN and parallel interfaces.

The original configuration may be modified by ordering the controller board with the desired interfaces and replacing the existing board with it.

Front2 Push Tractor

The Front2 Push Tractor is available as an option for the printer model.

Printer Cabinet

The printer cabinet is available as an option for the printer model. For the cabinet assembly, please refer to the instructions included in the cabinet packing box.

Installing the Controller Board

Follow the reported instruction in case of Controller Board replacement.

Handling the Controller Board

Attention: Do not remove the Controller Board from the protective package until instructed to do so. Static electricity, though harmless to you, can damage sensitive Controller Board components. Use the information in this section to avoid damaging a Controller Board.

- Limit your movement. Your movement can create static electricity that, when released to the Controller Board, can damage the electronic components on the Controller Board. Sliding your foot across carpeting is an example of how you create unwanted static electricity.
- Handle the Controller Board only by the edges and prevent others from making direct contact with it.
- Before removing the Controller Board from the protective package, ground the package to exposed metal at the back of the printer. This will release any static charge that may have developed on the package or on your body. Hold the package against the metal for at least two seconds.
- When you are instructed, remove the Controller Board and install it directly into the Controller Board slot without setting it down. If you have removed the Controller Board from the protective package and cannot immediately insert it in the printer, place the protective package on a flat surface, and set the Controller Board on top of the protective package.

Replacing the Controller Board

Attention: Ensure that the printer is powered off before installing or removing the Controller Board.

If the Controller Board is installed while the printer is powered on, the controller will not synchronize with the printer mechanism board.

Unpredictable printer behavior will result.

Perform the following steps to replace the Controller Board:

1. Ensure that the printer is powered off. Installing the Controller Board with the printer power on will result in unpredictable printer behavior.
2. Use the screwdriver that came in the Controller Board box to remove the existing Controller Board and pull out the card.

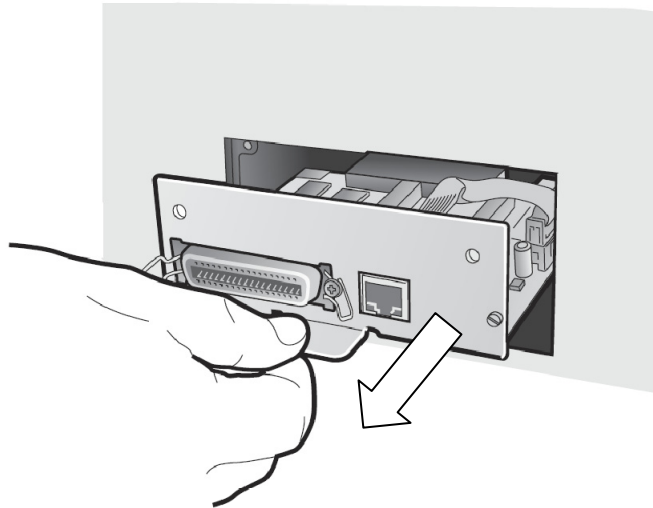

3. Use the information under “Handling the Controller Board” on the preceding page as you remove the Controller Board from its shipping box and from the protective package.
4. Align the left and right sides of the Controller Board with the guides in the printer and slide it into the slot.

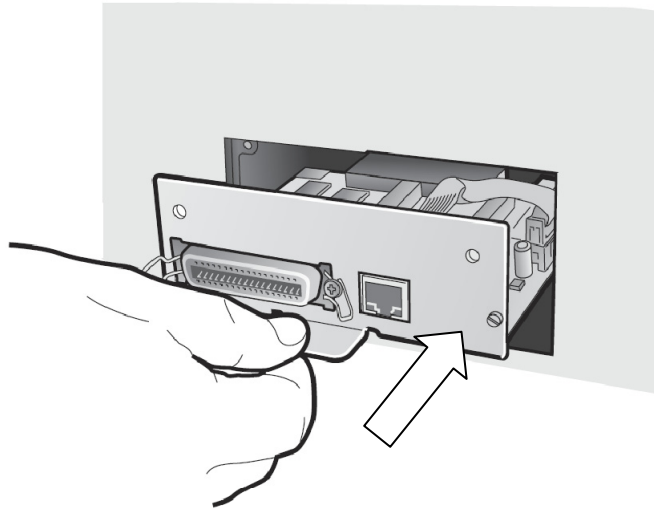

5. Gently push the Controller Board into the printer until it is seated in the connector inside the printer. The Controller Board is correctly seated in the printer when the Controller Board metal plate is aligned with the back profile of the slot.

6. Attach the Controller Board with the two screws using the screwdriver that came in the Controller Board box.

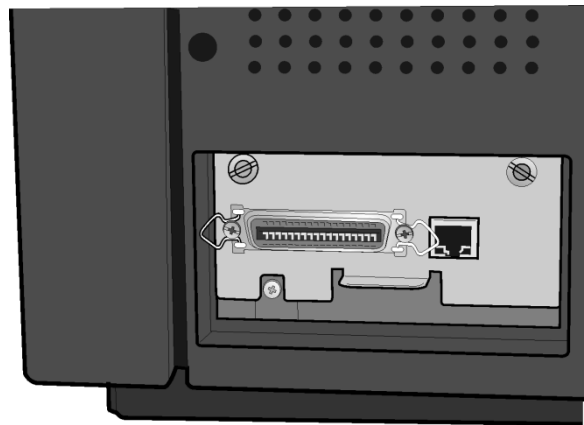

Printer Specifications

Printing Characteristics

Print Head	
Matrix	24 pins
Print Head Life	800 mil characters (draft)

Print Speed (cps)					
	Draft			Quality	
	HS Draft	Normal	Best Draft	NLQ	LQ
10 cpi	1300	950	500	300	150
12 cpi	-	1100	600	360	180
micro 15 cpi	-	1400	-	-	-
normal 15 cpi	-	950	600	450	225
Lines per minute @10 cpi in HS Draft mode	600 at 40 characters per line 450 at 80 characters per line 300 at 136 characters per line				

Throughput (ISO/IEC 10561)
750 pages per hour

Print Matrix (horizontal x vertical)

	Draft			Quality	
	HS Draft	Normal	Best Draft	NLQ	LQ
10 cpi	9 x 12	12 x 12	12 x 24	36 x 12	36 x 24
12 cpi	-	10 x 12	10 x 24	30 x 12	30 x 24
micro 15 cpi	-	8 x 8	8 x 16	24 x 8	24 x 16
normal 15 cpi	-	12 x 12	12 x 24	24 x 12	24 x 24
17,1 cpi	-	14 x 12	14 x 24	21 x 12	21 x 24
20 cpi	-	12 x 12	12 x 24	18 x 12	18 x 24
micro 24 cpi	-	10 x 8	10 x 16	15 x 8	15 x 16
normal 24 cpi	-	10 x 12	10 x 24	15 x 12	15 x 24

Print Density (characters per inch)

Normal	10 - 12 - 15 - 17.1 - 20 - 24
--------	-------------------------------

Line length (number of characters)

10 cpi	136	17.1 cpi	233
12 cpi	163	20 cpi	272
15 cpi	204	24 cpi	326

Vertical Spacing

6, 8, 12 lpi
3, 4, 6, 8, 12 lines/30 mm
n/62, n/72, n/180, n/216, n/360 per inch

Print Styles

Draft - Courier - OCR B - Gothic - Prestige - Present - OCR A - Script

Print Attributes

Sub-superscript, Underline, Overscore, Italics, Emphasized, Double Strike, Shadow, Enlarged, Compressed

Graphic Resolution (dots per inch)

horizontal	60, 80, 90, 120, 180, 360
vertical	60, 72, 180

Characters Sets

Standard PC IBM Character Sets	CS1 and CS2
EPSON National Variations	USA, France, Germany, United Kingdom, Denmark-1, Sweden, Italy, Japan, Spain-1, Norway, Denmark-2, Spain-2, Latin America
IBM and EPSON Character Sets	USA (CP437), Greek (CP437-G), Slavic (CP437SL), Multilingual (CP850), Greek (CP851), Eastern Europe (CP852), Turkish (CP 853), Cyrillic (CP855), Turkish (CP857), Euro PC Multilingual (CP858), Portugal (CP860), Hebrew (CP862), Canada/France (CP863), Arabic (CP864), Denmark/Norway (CP865), Russian (CP866), Turkish2 (CP867), OCR-A (CP876), OCR-B (CP877), Farsi (CP1098), Latin 2 Windows (CP1250), Cyrillic Windows (CP1251), Latin 1 Windows (CP1252), Greek Windows (CP1253), Turkish Windows (CP1254), Hebrew Windows (CP1255), Arabic Windows (CP1256), Baltic Windows (CP1257), 96 GREEK, GOST, TASS, MAZOWIA, UKRANIAM, KOI8-U, FARSI1, FARSI2
ISO Character Sets	8859/1 (Latin1), 8859/2 (Latin2), 8859/3 (Latin3), 8859/4 (Latin4), 8859/5 (Latin/Cyrillic), 8859/6 (Latin/Arabic), 8859/7 (Latin/Greek), 8859/8 (Latin/Hebrew), 8859/9 (Latin5). 8859/15 (Latin9)

Bar Codes

UPC-A, UPC-E, EAN-8, EAN-13, UPC-EAN 2, UPC-EAN 5, Code GP, MSI Plessey, Code BCD, C2/5-3 BAR, Code 39, Code 128, Code 11, Code 93, Codabar, 2/5 Bidirectional, 2/5 Interleaved, 2/5 Industrial, 2/5 Matrix, Postnet

Emulations

- EPSON LQ Series (ESC/P)

- IBM Proprinter XL24

- IBM Personal Printer 2391+

- ANSI 3.64

Paper Handling

Base Configuration

1 FRONT1 TRACTOR

Fanfold width:	76 to 432 mm	(3 to 17 inches)
----------------	--------------	------------------

Copies:	1 original + 7 copies	Max. thickness 0,635 mm (0.025 inches)
---------	-----------------------	--

1 FRONT2 TRACTOR

Fanfold width:	76 to 432 mm	(3 to 17 inches)
----------------	--------------	------------------

Copies:	1 original + 7 copies	Max. thickness 0,635 mm (0.025 inches)
---------	-----------------------	--

Standard Functions

- Automatic print head gap adjustment (AGA)
- Automatic paper path switching via operator panel or S/W commands
- Paper parking
- Plug & Play capability
- Bar Code printing
- Automatic fanfold positioning for tear-off, selectable time-out
- Setting and storage of paper format and print conditions for each paper path in the non volatile memory
- Printing of the macro characters using the Compuprint native commands

Physical and Electrical Characteristics

Interfaces

Parallel	Centronics Compatible Bi-directional (IEEE-1284) nibble and byte modes - 36 pin Amphenol connector, 7/8 data bits
	Receive Buffer: max. 128 Kbytes
Serial	RS-232/C - dB 9 connector
	Baud Rate: 300 to 115200 bps, 7/8 data bits, DTR & XonXoff flow
	Receive Buffer: max. 128 Kbytes
USB	Type B USB 2.0 Compatible Bi-directional - 4 pin connector, 12Mbit/s
LAN	10BASE-T – 100BASE-TX – RJ45 8 pin connector
Automatic interface switching	

Reliability	
MTBF	Mean Time between failure: 10000 hours at 25% DC
MTTR	Mean Time To Repair: 30 minutes
Workload	60000 pages/month (ECMA 132 - 4 hours for 22 days)
Printer Life	5 years or 10000 hours @25%
Duty Cycle	Operating: no limitations

Power Supply	
UNIVERSAL	From 90 to 244 VAC
Power Output	Max. 215 W
Power Consumption	Standby: less than 24W ---- Average Printing: 149 W

Noise Level	
< 55 dBA	

Environment Conditions		
Storage Conditions		
	Temperature	-40° to 50° C
	Relative Humidity	10% to 90% RH (non condensing)
Operating Conditions		
	Temperature	10° to 38° C
	Relative Humidity	10% to 90% RH (non condensing)

Paper Conditions		
	Temperature	16° to 24° C
	Relative Humidity	40% to 60% RH (non condensing)

Physical dimensions	
Height	350 mm (13,77 inches)
Width	720 mm (28,34 inches)
Depth	400 mm (15,75 inches)
Weight	33 kg

Physical dimensions – Printer Cabinet	
Height	printer table: 666 mm (16,92 inches)
	paper stacker: 512 mm (13,01 inches)
Width	726 mm (18,44 inches)
Depth	without paper stacker: 522 mm (13,26 inches)
	with paper stacker: 794 mm (20,17 inches)
Weight	40 kg

Consumables

Black "Long Life" cartridge (25 million characters)	PRKN102-1
---	-----------

Options

Printer Cabinet	PRFN-PD2
Front2 Tractor	PRFN2TR6
Controller Parallel-Serial-USB	PRAN130
Controller Parallel-Ethernet LAN	PRAN130N

Standards

CE Mark
UL 1950; CSA 22.2 n.950; EN 60950
CISPR 22/EN 55022-class B; FCC rules part 15, subpart J, class B
EN 55024

User Information according to European Directive 2002/95/EC and 2003/108/EC



This unit must be recycled or discarded according to applicable local and national regulations.

The symbol shown above, applied to the product or on its packing, indicates that, at end of life, the product is not to be thrown away, or disposed as unsorted municipal waste, but separately collected.

SFERAL WWT encourage owners of information technology (IT) equipment to responsibly recycle their equipment when it is no longer needed.

Customer that needs to dispose this equipment must contact the produce and follow the collection framework available locally for the return, recycling and recovery of WEEE.

Customer participation to the separate collection is important to minimize any potential effects on the environment and human health, due to the potential presence of hazardous substances in the equipment, and aids the reuse and recycle of the materials by which the equipment is made.

Uncorrect disposal of the product by the customer will be punished according to the local regulations and laws.

78413012-001

Sferal WWT proprietary. All trademarks herein recalled are registered by their respective companies.